



2024 AG AVIATION EXPO

NATIONAL AGRICULTURAL AVIATION ASSOCIATION | FORT WORTH, TEXAS

EXHIBITOR SERVICES KIT

Ag Aviation Expo 2024

November 18-21, 2024

Fort Worth Convention Center

Fort Worth, TX

Welcome

Dear Ag Aviation Expo 2024 Exhibitor,

T3 Expo is proud to have been selected as the official service contractor for Ag Aviation Expo 2024. This document contains information and order forms for many of the services that we offer. Please take a few minutes to review and read this material carefully. Our goal is to help make your participation at this event a success. We recommend placing your orders as soon as possible in order to take advantage of the advance order discounts.

Our T3 Expo Customer Service department is ready to assist you with all your exhibiting needs; please contact help@t3expo.com or call +1.888.698.3397.

Thank you for your business,
From all of us at T3 Expo

Use our
INTERACTIVE
TABLE OF CONTENTS
for EASY NAVIGATION



Table of Contents

IAEE GUIDELINES

IAEE Guidelines for Display Rules & Regulations 4-35

T3 EXPO INFORMATION

Show Information..... 37
Important Dates & Deadlines Checklist 38
Preshow Checklist 39
On-site Checklist 40

SHIPPING INFORMATION

Material Handling 42
Shipping Addresses..... 43
Vehicle Spotting Fee 44
Cartload Service..... 45
TForce Freight Trade Show Form..... 46-47
Advance Shipment Labels 48
Direct Shipment Labels 49
Hanging Sign Advance Shipment Labels 50

T3 SERVICE INFORMATION & FORMS

10' x 10' Presta™ Rental Exhibit Package..... 52
10' x 20' Presta™ Rental Exhibit Package..... 53
10' x 10' Booth Package..... 54
10' x 20' Booth Package..... 55
Print Production Artwork Requirements 56
Carpet Options 57
Carpet & Padding Order Form 58
Furniture – Standard Chairs 59
Accessories / Pipe & Drape 60
Furniture / Accessories / Pipe & Drape Order Form 61
Display Tables & Counters..... 62
Display Tables & Counters Order Form 63
Display Labor & Forklift Order Form..... 64
Hanging Sign Order Form 65
Hanging Sign Description & Position 66
Accessible Storage & Cleaning Order Form 67
AFR Furniture Rental Form 68

T3 CUSTOM FURNITURE ORDER FORMS

Custom Furniture Order Forms..... 70-82

ADDITIONAL INFORMATION & FORMS

Payment Information..... 84
Notification Of Intent To Use EAC 85
Third Party Authorization 86
United States Fire Department Regulations 87
Fort Worth Labor Guidelines 88

ANCILLARY INFORMATION & FORMS

Electrical & Plumbing Services Order Forms..... 90-101
FWCC Exhibitor Telecom Product List (coming soon) 102
FWCC WiFi Options (coming soon)..... 103
FWCC Rigging Pricing & Policies..... 104-109
FWCC Service Providers List 110
Floral Services Order Form 111-112



International
Association of
Exhibitions and Events®

Guidelines for Display Rules and Regulations

2023 North American Update

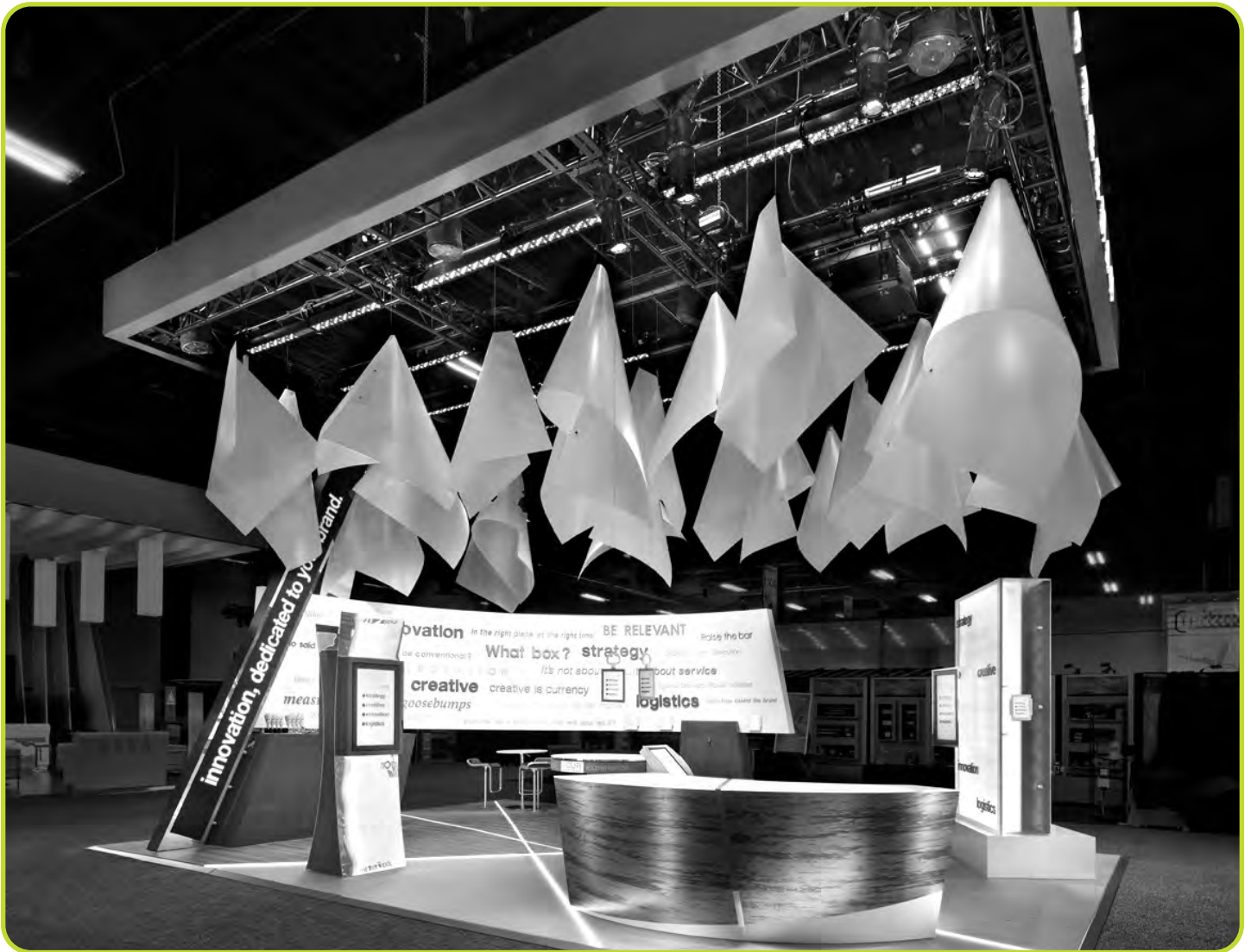

The following **Guidelines for Display Rules and Regulations** have been established by the International Association of Exhibitions and Events® (IAEE) to assist in promoting continuity and consistency among North American exhibitions and events. This revised 2023 edition is offered as a resource for exhibition and event organizers to use in creating consistent and fair exhibiting standards for their events.

Recognizing that every show is unique, IAEE presents the information contained within as recommendations or suggestions for exhibiting standards each Organizer should consider. Organizers are encouraged to review the **Guidelines** and then develop their own show-customized set of exhibiting rules and regulations based on the individual features of their specific exhibition or event.

Once an Organizer has finalized their show's official set of display rules, it is good practice to provide access to a digital copy within the show's exhibitor prospectus, an exhibitor services kit, and the official rules and regulations pertaining to exhibitor participation. By providing exhibitors with the professional standards expected of their displays and participation, they will be prepared to properly design, build and plan their booth's layout and content allowing for an environment where all exhibitors will have the opportunity for successful interaction with their audiences.

Important Note: Although compliance with fire, safety, the U.S. Americans with Disabilities Act (ADA), and other state, federal or provincial government requirements have been addressed, Organizers should always check with exhibition service contractors and the facility for specific details on local regulations and requirements.

*IAEE is a global association that serves as the foremost authority on exhibitions and events management and operations, and these **Guidelines** are the model for most North American exhibitions and events but in all instances, organizations should consult their legal counsel. In no event shall IAEE be held liable for damages of any kind in connection with the material, methods, information, techniques, opinions or procedures expressed, presented, or illustrated in these **Guidelines** or related materials.*



International
Association of
Exhibitions and Events®

TABLE OF CONTENTS

LINE-OF-SIGHT STYLE.....1

- Linear or In-line Booth.....1
 - Dimensions1
 - Use of Space1
- Corner Booth2
- Perimeter Booth2
 - Dimensions and Use of Space2
- End-cap Booth3
 - Dimensions and Use of Space3
- Peninsula Booth4
 - Dimensions and Use of Space4
- Split Island Booth5
 - Dimensions and Use of Space5
- Island Booth6
 - Dimensions and Use of Space6
- Extended Header Booth 20ft (6.10m) or Longer7
 - Dimensions and Use of Space7
- Remote-Controlled Devices8

CUBIC CONTENT STYLE.....8

OTHER IMPORTANT CONSIDERATIONS8

- Canopies and Ceilings9
- Structures and Tie-Offs10
 - Structures10
 - Tie-offs.....10
- Hanging Signs and Graphics.....10
- Teardrop Signs and Tents10
- Truss.....11
- Video Displays.....11
- Towers and Multi-story Exhibits.....11
- U.S. Americans with Disabilities Act (ADA)11

TABLE OF CONTENTS (continued)

ISSUES COMMON TO ALL BOOTH TYPES11

- Structural Integrity.....12
- Flammable and Toxic Materials12
- Hazardous Waste.....12
- Storage12
- Electrical13
- Lighting.....13
- Demonstrations.....14
- Sound/Music14
- Vehicles (For Both Gas and Electric Vehicles)15
- Fire Equipment.....15
- Hanging Signs.....15

ADVISORY NOTES TO EXHIBITION ORGANIZERS.....15

- Hardwall Booths16
- Perimeter Openings.....16
- Pipe and Drape16
- Product Height16
- Height Variances16
- Environmental Responsibility.....16

APPENDIX.....17

IAEE EXTENDS A SPECIAL THANK YOU TO THE FOLLOWING VOLUNTEERS FOR THEIR INPUT:28

IAEE has identified two distinctly different styles of show display regulations. One style is “Line-of-Sight” while the second is “Cubic Content.” Organizers should decide which style is best suited to their event or designated section of the event. Organizers might find line of sight rules are best for linear booths and cubic content rules for configurations of island, peninsula or perimeter booths.

LINE-OF-SIGHT STYLE

Line-of-Sight display rules provide restrictions on certain areas of booths to allow attendees to view neighboring booths in their line of sight as they walk the floor. There are a variety of booth types, and each one is addressed below with specific insight on how to implement Line-of-Sight regulations.

LINEAR OR IN-LINE BOOTH

The ability to have products or services easily seen by attendees as they walk the aisles is essential to all exhibitors, and that is the basis for including a Linear Booth Line-of-Sight setback rule. Linear Booths, also called “in-line” booths, are generally arranged in a straight line and have neighboring exhibitors on their immediate right and left, leaving only one side exposed to the aisle.

Dimensions

For purposes of consistency and ease of layout and/or reconfiguration, floor plan design in increments of 10ft (3.05m) has become the de facto standard in the United States. Therefore, unless constricted by space or other limitations, Linear Booths are most commonly 10ft (3.05m) wide and 10ft (3.05m) deep, i.e. 10ft by 10ft (3.05m by 3.05m). A maximum back wall height limitation of 8ft (2.44m) is specified to prevent display materials from imposing on neighboring exhibits behind the back wall.

Use of Space

Regardless of the number of Linear Booths utilized, e.g. 10ft by 20ft (3.05m by 6.10m), 10ft by 30ft (3.05m by 9.14m), 10ft by 40ft (3.05m by 12.19m), etc., display materials should be arranged in such a manner so as not to obstruct sight lines of neighboring exhibitors. The maximum height of 8ft (2.44m) is allowed only in the rear half of the booth space, with a 4ft (1.22m) height restriction imposed on all materials in the remaining space forward to the aisle. Note: When three or more Linear Booths are used in combination as a single exhibit space, the 4ft (1.22m) height limitation is applied only to that portion of exhibit space which is within 10ft (3.05m) of an adjoining booth.

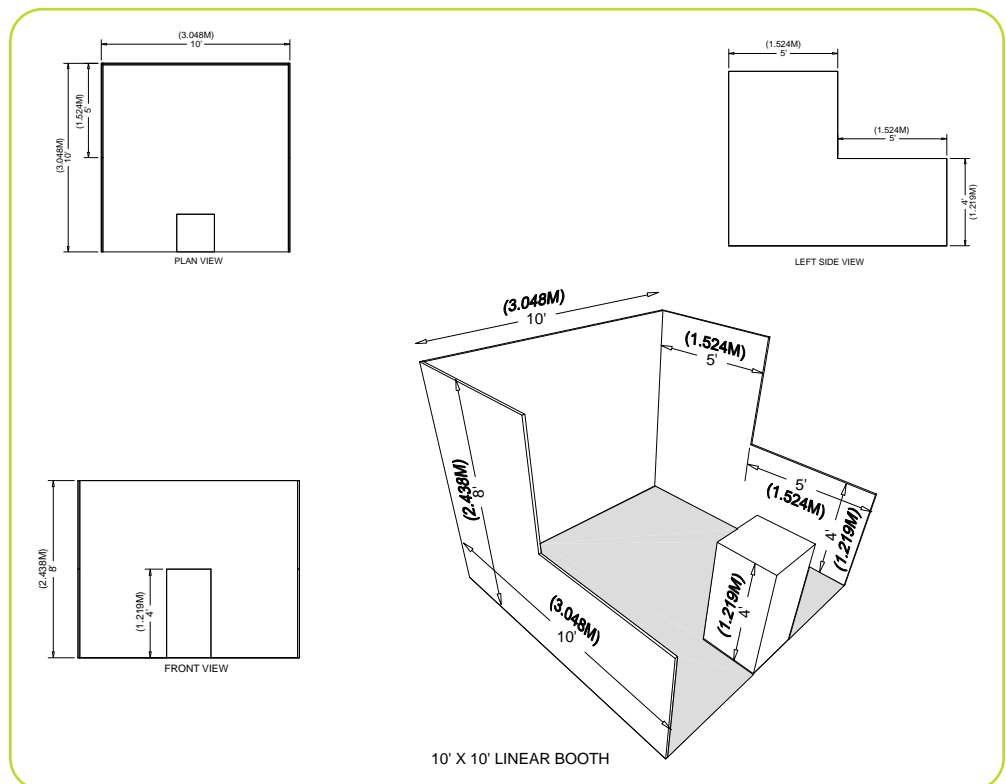

CORNER BOOTH

A Corner Booth is a Linear Booth at the end of a series of in-line booths with exposure to intersecting aisles on two sides. All guidelines for Linear Booths apply.

PERIMETER BOOTH

A Perimeter Booth is a Linear Booth that backs to an outside wall of the exhibit facility rather than to another exhibit.

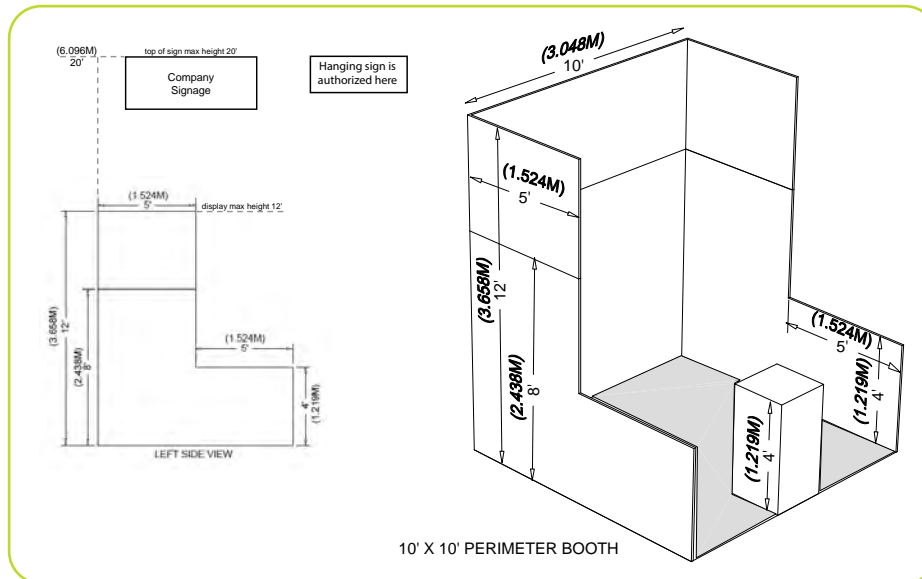

Dimensions and Use of Space

All guidelines for Linear Booths apply to Perimeter Booths except that the typical maximum back wall height for Perimeter Booths is 12ft (3.66m).

END-CAP BOOTH

An End-cap configuration is essentially an in-line (linear) booth placed in the position of a Peninsula or Split Island. For shows that have Line-of-Sight rules and not Cubic Content, this configuration must follow the dimensions below. Organizers should be alert to exhibitors reserving End-cap configurations to ensure they do not violate Linear Booth Line-of-Sight regulations for neighboring exhibits. (In most cases, this booth style is not recommended due to the Line-of-Sight issues, and Organizers should be aware of these challenges when using them.)

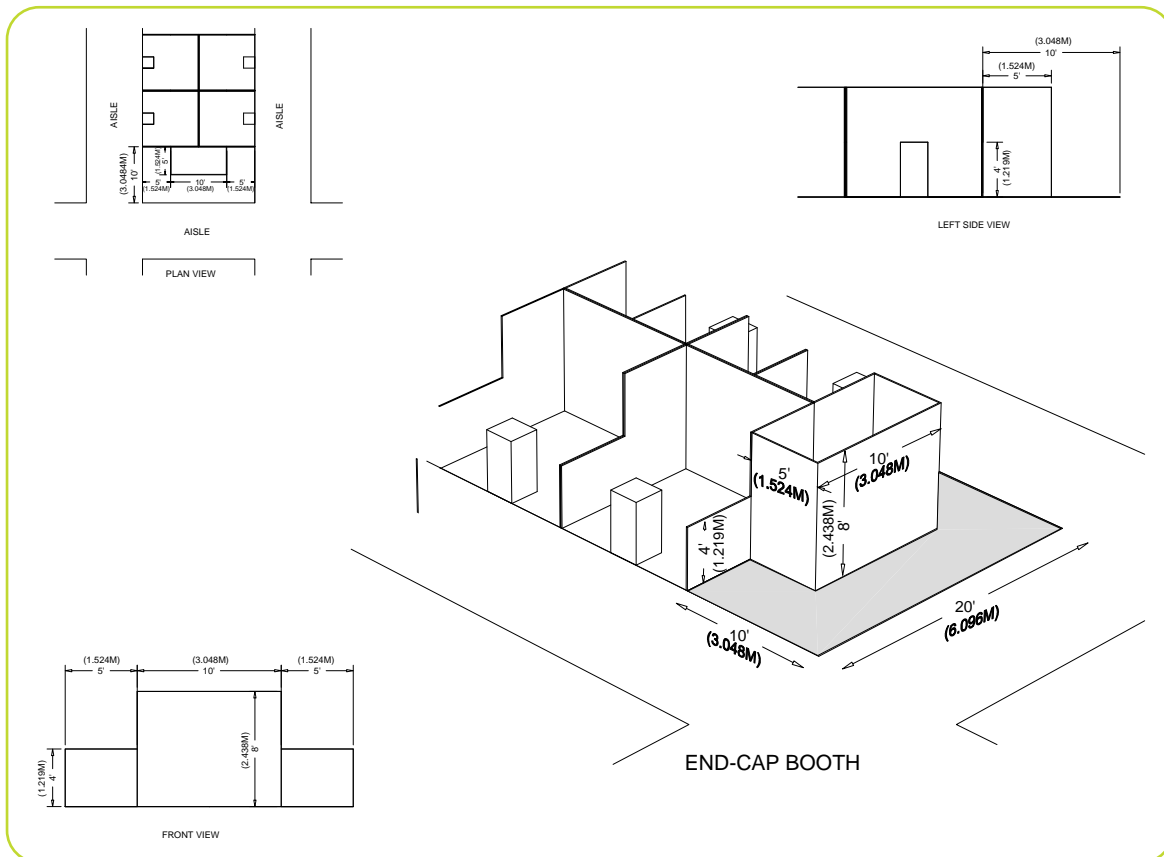

Dimensions and Use of Space

End-cap Booths are generally 10ft (3.05m) deep by 20ft (6.10m) wide. The maximum back wall height allowed is 8ft (2.44m) and the maximum backwall width allowed is 10ft (3.05m) at the center of the backwall with a maximum 5ft (1.52m) height on the two side aisles. Within 5ft of the two side aisles, the maximum height for any display materials is 4ft.

PENINSULA BOOTH

A Peninsula Booth is exposed to aisles on three sides. There are two types of Peninsula Booths: (a) one which backs to Linear Booths, and (b) one which backs to another Peninsula Booth which is referred to as a “Split Island Booth.”

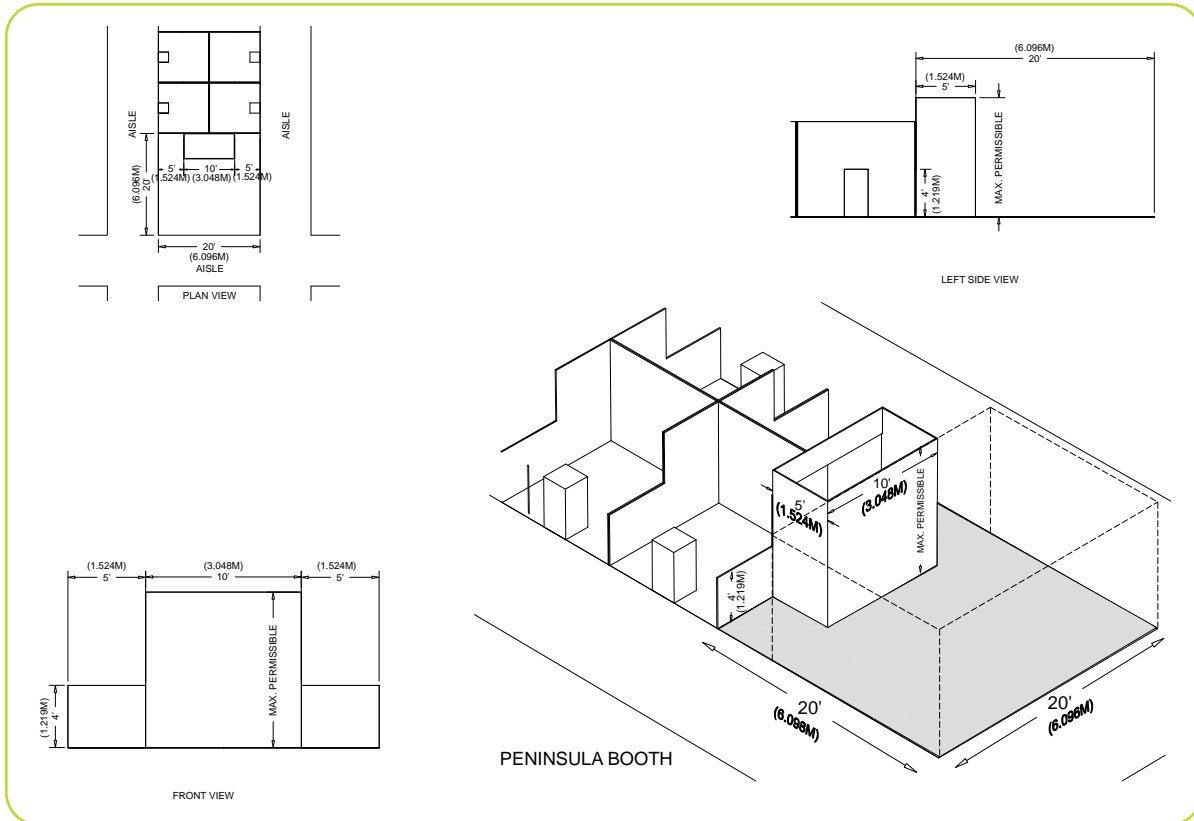

Dimensions and Use of Space

A Peninsula Booth is usually 20ft by 20ft (6.10m by 6.10m) or larger. When a Peninsula Booth backs up to two Linear Booths, the back wall is restricted to 4ft (1.22m) high within 5ft (1.52m) of each aisle, permitting adequate line of sight for the adjoining Linear Booths. A typical maximum height range allowance is 16ft to 20ft (4.88m to 6.10m), including signage for the center portion of the back wall. Double-sided signs, logos and graphics shall be set back 10ft (3.05m) from adjacent booths.

SPLIT ISLAND BOOTH

A Split Island Booth is a Peninsula Booth which shares a common back wall with another Peninsula Booth.

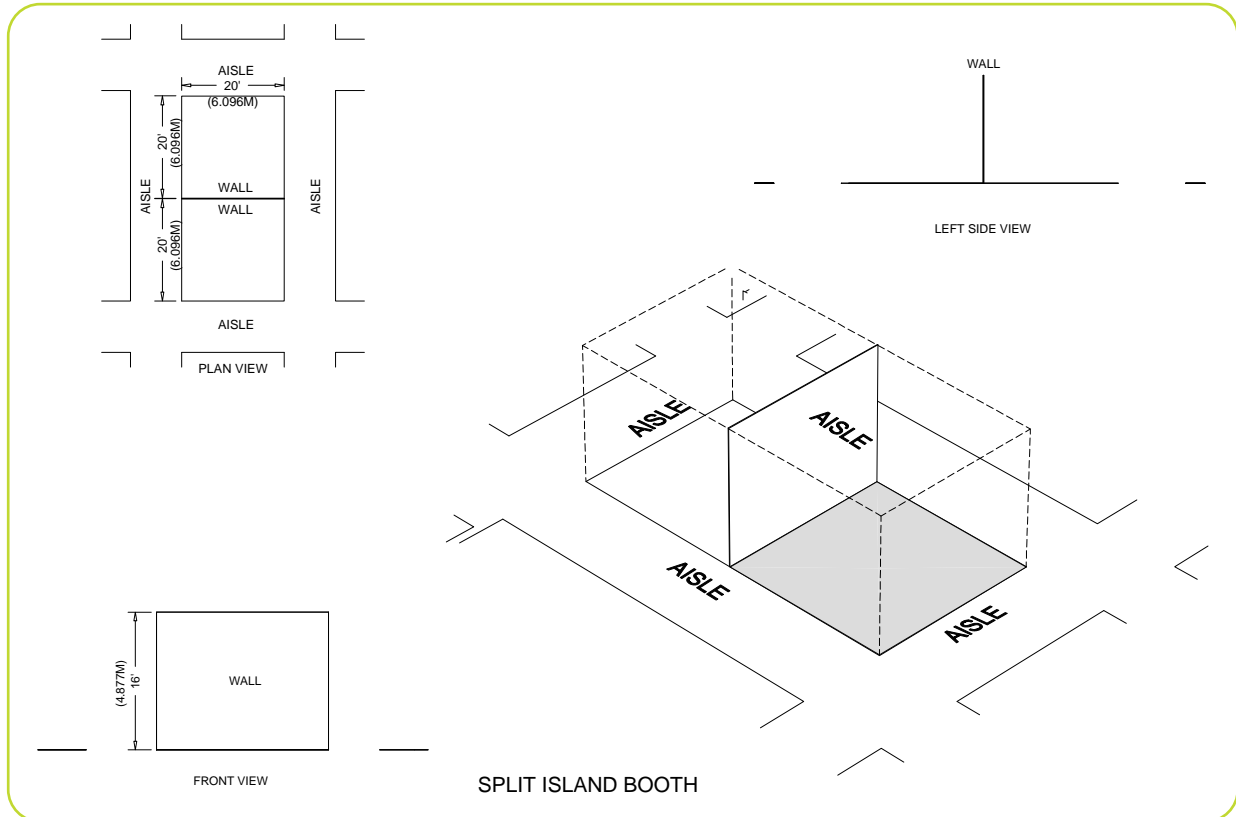

Dimensions and Use of Space

The entire Cubic Content of this booth may be used, up to the maximum allowable height, without any back wall Line-of-Sight restrictions. A typical maximum height range allowance is 16ft to 20ft (4.88m to 6.10m), including signage. The entire Cubic Content of the space may be used up to the maximum allowable height. Double-sided signs, logos and graphics shall be set back 10ft (3.05m) from adjacent booths.

For large shows with big exhibitors, it may be difficult to maintain the entire booth and hanging sign to be within 16ft. If you make it 20 ft then you run the risk of lots of large booths (with or without signs) being 20 ft and dwarfing all around them. That is fine as long as everyone is aware of it. An alternative could be to offer a max booth height of 16 ft and each exhibitor must have a 4 ft gap between the top of the booth and the bottom of the hanging sign. The only exception is if the booth and hanging sign can stay below 16ft. It is far from perfect but does allow at least the ability to see through a booth.

ISLAND BOOTH

An Island Booth is any size booth exposed to aisles on all four sides.

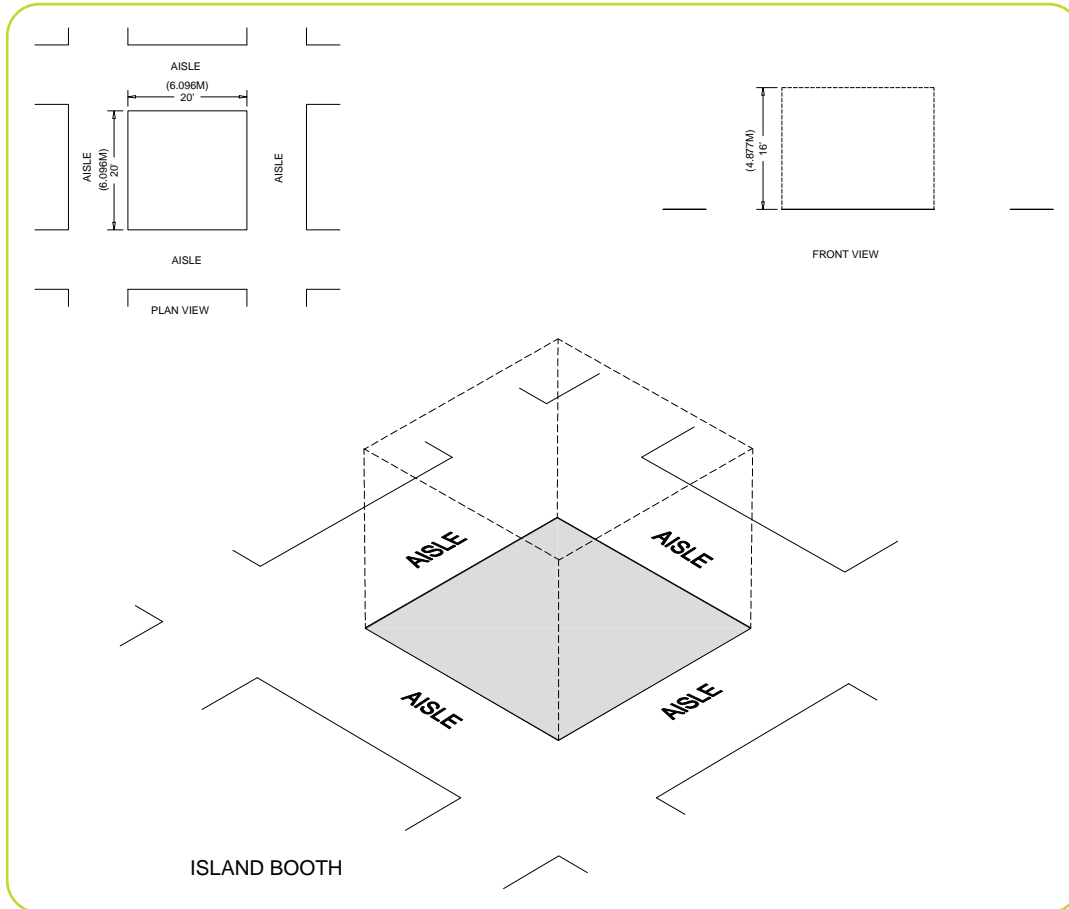

Dimensions and Use of Space

An Island Booth is typically 20ft by 20ft (6.10m by 6.10m) or larger, although it may be configured differently. Island booths should not be allowed at less than 400 sq ft. Island booths at 200 or 300 sq ft basically result in frustrating everyone behind them. The entire Cubic Content of the space may be used up to the maximum allowable height, which is usually a range of 16ft to 20ft (4.88m to 6.10m), including signage.

EXTENDED HEADER BOOTH 20FT (6.10M) OR LONGER

An Extended Header Booth is a Linear Booth 20ft (6.10m) or longer with a center extended header.

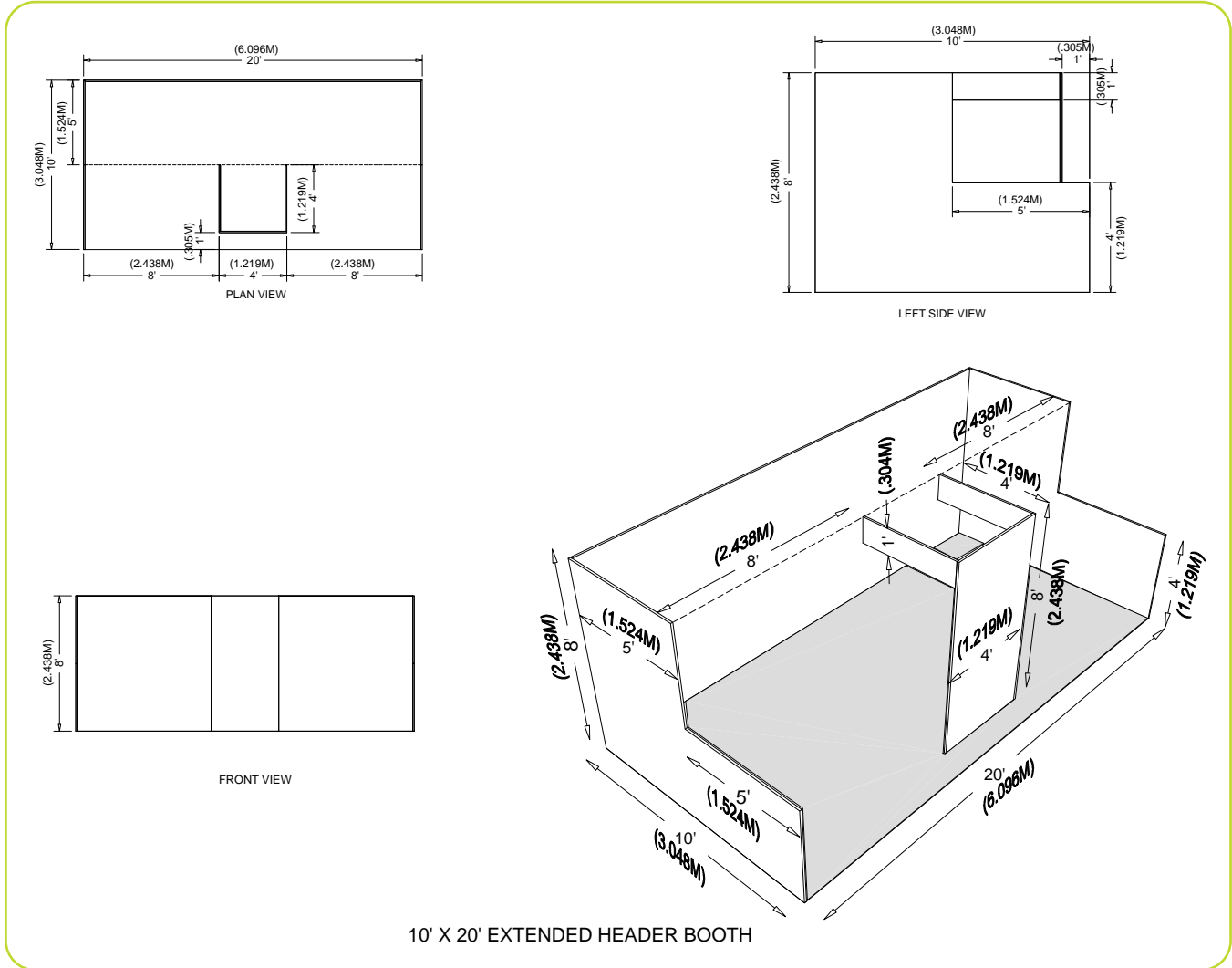

Dimensions and Use of Space

All guidelines for Linear Booths apply to Extended Header Booths, except that the center extended header has a maximum height of 8ft (2.44m), a maximum width of 20 percent of the length of the booth, and a maximum depth of 9ft (2.7m) from the back wall.

CUBIC CONTENT STYLE

Cubic Content style allows exhibits to fully occupy the width, depth and height of the booth footprint. For example, a 10ft by 10ft (3.05m x 3.05m) booth would be allowed to utilize the full volume of the cube of a 10ft wide (3.05m) x 10ft deep (3.05m) x 8ft (2.44m) high area.

It is the choice of the Organizer to allow use of full Cubic Content in linear exhibit space or to observe the Line-of-Sight set-back rule. It is common at certain types of exhibitions or events to eliminate the Line-of-Sight requirement for Linear, End-cap, and Peninsula Booths that back up to Linear Booths. This permits exhibitors to utilize the full Cubic Content of the booth.

Organizers that utilize Cubic Content in Linear Booths do so for one or all of these reasons:

- Cubic Content is more conducive to certain types of product displays or experiences.
- Cubic Content maximizes the exhibit space and investment.
- Generally, exhibitions outside North America utilize Cubic Content making the show friendlier to international exhibitors.
- Cubic Content reduces the need to police exhibits to enforce Line-of-Sight setback rules.

Use of Cubic Content may create situations where the Organizer must address exhibits that have unfinished walls. A determination must be made as to responsibility for finishing these unfinished walls.

It is prudent for the Organizer considering Cubic Content to examine the concerns, advantages and disadvantages prior to putting Cubic Content guidelines into practice. It is often wise to consult with the exhibition's Exhibits Advisory Board or perhaps conduct a focus group of the exhibition's or event's exhibitors to determine their interest and gain their feedback and support for the concept. Organizers must be proactive in communicating with exhibitors and understand the effect it will have on the exhibition or event.

To learn more about Cubic Content, read the *IAEE White Paper: Evaluating and Implementing Cubic Content into Linear Exhibit Space* in the Appendix on page 17.

OTHER IMPORTANT CONSIDERATIONS

REMOTE-CONTROLLED DEVICES

Products such as remote-controlled cars, drones, planes, helicopters, robots, etc. are to be demonstrated in a safely controlled area of the exhibit floor (i.e. Demonstration Area). When a remote-controlled device is to be used for the purpose of demonstrating a product that requires use of an area outside of the exhibitor-assigned booth space, the Organizer will provide a Demonstration Area for this purpose. The Demonstration Area should include safe netting or other barrier appropriate to accommodate product(s) being demonstrated and be included on the master floor plan submitted for Fire Marshal approval. Each individual facility reserves the right to determine what constitutes a safe and controlled Demonstration Area prior to final plan approval.

NOTE for Drone Operation: Local facility and city ordinances are in effect in most areas and prohibit drone activity near the public or in public spaces. The accepted drone default regulation is the [FAA Small UAS Rule Part 107](#) which requires drone operators to obtain a Remote Pilot Certificate. Commercial regulations often require permits and insurance.

CANOPIES AND CEILINGS

A canopy sign is similar to an awning on a building, except it does not include the goal of providing shelter. It extends from a booth to serve the function as a marquee. Canopies, including ceilings, umbrellas and canopy frames, can be either decorative or functional (such as to shade computer monitors from ambient light or to allow for hanging products). Canopies for Linear or Perimeter Booths should comply with Line-of-Sight requirements. (See “Use of Space” for Linear or Perimeter Booths, and height limits).

The bottom of the canopy should not be lower than 7ft (2.13m) from the floor within 5ft (1.52m) of any aisle. Canopy supports should be no wider than three inches 3in (.08m). This applies to any booth configuration that has a sight line restriction, such as a Linear Booth. Fire and safety regulations in many facilities strictly govern the use of canopies, ceilings and other similar coverings. Check with the appropriate local agencies prior to determining specific exhibition rules.

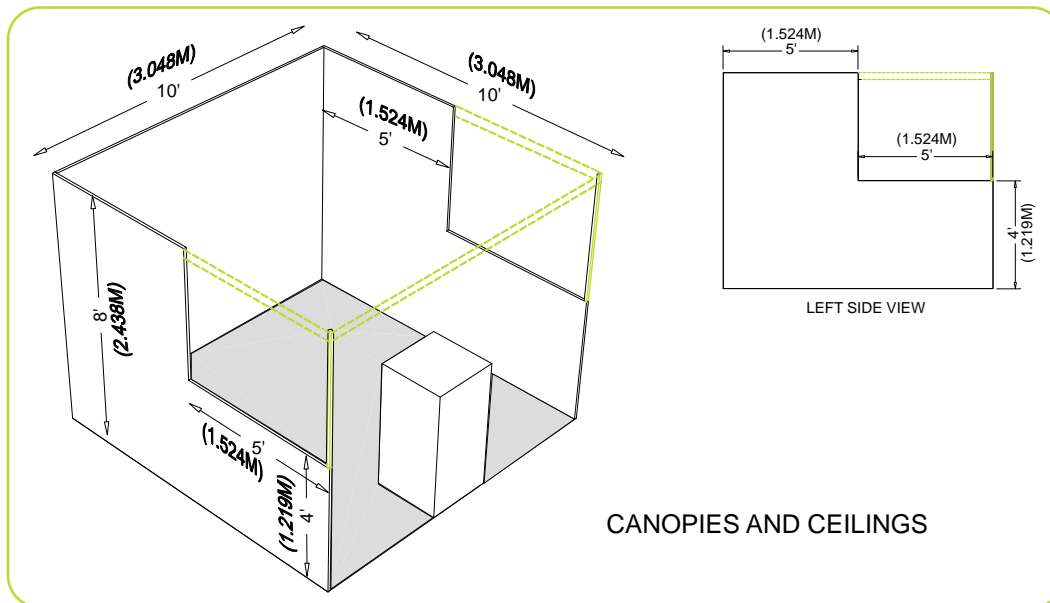

STRUCTURES AND TIE-OFFS

Structures

Show Organizer requires a stamped certification from a design professional (Civil or Structural Engineer) registered in the state where the Event will be held affirming all calculations and specifications for any custom-built suspended elements such as but not limited to non-serially manufactured signs, lightboxes, headers, video wall surrounds, and entry portals. For additional assistance regarding these requirements, please reach out to the rigging vendor.

Tie-offs

Show Organizer reserves the right to request a stamped certification from a design professional (Civil or Structural Engineer) registered in the state where the Event will be held affirming all calculations and specifications and/or a peer review from such registered design professional for attachment of any structure to provide additional support terminating to the venue (Ex. Tie-off of header, seismic lines, tie-off of video walls). If you anticipate needing this service, please reach out to the rigging vendor review and pre-authorization.”

HANGING SIGNS AND GRAPHICS

Most exhibition and event rules allow for Hanging Signs and Graphics in all standard Peninsula and Island Booths, usually to a maximum height range of 16ft to 20ft (4.88m to 6.10m) from the top of the sign, or as determined by the Organizer. End-cap Booths do not qualify for Hanging Signs and Graphics. The distance is measured from the floor to the top of the sign. Whether suspended from above, or supported from below, they should comply with all ordinary use-of-space requirements. For example, the highest point of any sign should not exceed the maximum allowable height for the booth type. (An exception to this rule is made for Perimeter Booths, which can have a 12ft [3.66m] backwall but max sign height can be 20ft. [6.10m]. See page 2 Perimeter Booth for diagram.)

Hanging Signs and Graphics should be set back 10ft (3.05m) from adjacent booths and be directly over contracted space only.

Approval for the use of Hanging Signs and Graphics, at any height, should be received from the Organizer at least 60 days prior to installation. Variances may be issued at the Organizer’s discretion. Drawings should be available for inspection.

Sign Hanging Points must be engineered, and the hardware must be domestic, forged, shouldered, rated, and stamped with Working Load Limit (WLL). All overhead rigging must comply with facility and show management regulations. The official contractor and/or facility will require an engineered print of all truss and lighting rigging including rigging point loads, as well as any ground supported truss structures or LED video walls. . All submitted files should be in DWG format. This information is typically required at least three weeks out form the first day of move-in of an event. Electrical signs must be in working order and in accordance with the National Electrical Code. If any hang point exceeds 200 lbs. please notify the official contractor for official authorization.

TEARDROP SIGNS AND TENTS

Placement of Teardrop flags must be positioned in the back ½ of all linear booths.

Tents – must have no copy on the sides or back side and not exceed 8ft height limit. I would also specifically address the tents with extended ceilings, see below. Under no circumstances are these acceptable in a linear booth regardless of whether they have copy or not.

TRUSS

Truss is a frame used to carry a cover over a booth or suspend lighting or technical equipment over a booth. Some shows will allow to go over the height limit but require plans to the organizer and service contractor for approval.

VIDEO DISPLAYS

Show Organizer reserves the right to request approval from a registered design professional (Civil or Structural Engineer) and/or a peer review from a registered design professional for all non-serially manufactured LED and Video Display systems. All LED and video display systems must comply to ANSI E1.50-1. This applies to ground supported and suspended LED and Video Display systems. If you anticipate needing this service, please reach out to your rigging vendor.

TOWERS AND MULTI-STORY EXHIBITS

A Tower is a free-standing exhibit component separate from the main exhibit fixture. The height restriction is the same as that which applies to the appropriate exhibit space configuration being used. Fire and safety regulations in many facilities strictly govern the use of Towers. A building permit or safety lines may be required.

A Multi-story Exhibit is a booth where the display fixture includes two or more levels. In many cities, a Multi-story Exhibit requires prior approval by the exhibit facility, and/or relevant local government agency, as well as the Organizer because it is deemed to be a “structure” for building purposes. The city building department generally needs to issue a building permit based on an application and drawings prepared and submitted by a licensed architect or engineer. Exhibitors should obtain local building regulations early on to ensure that all time constraints are met. Organizers should be prepared to assist exhibitors in this application process.

It is recommended that Organizers require exhibitors to provide engineering stamped documents for all Multi-story Exhibits and towers over 8ft (2.44m) in height. If engineering stamps are not required, exhibitors using these types of structures should, at a minimum, provide drawings for inspection.

ISSUES COMMON TO ALL BOOTH TYPES

U.S. AMERICANS WITH DISABILITIES ACT (ADA)

In the U.S., all exhibiting companies are required to be in compliance with the U.S. Americans with Disabilities Act (ADA), and are encouraged to be sensitive, and as reasonably accommodating as possible, to attendees with disabilities. Information regarding ADA compliance is available from the U.S. Department of Justice ADA Information Line (800) 514-0301, and from the ADA website at www.ada.gov.

Some examples of how to design an exhibit for ADA compliance:

- Make exhibits wheelchair accessible by ramping raised exhibit flooring without extending a ramp into the aisle. Note: a standard wheelchair ramp should have a grade no steeper than 1:12. This means that for every inch of rise (change in height), there should be 12 inches of run (change in length). Ramps should have a minimum width of 36 inches.
- Ramp the entry or use hydraulic lifts to trailer exhibits.
- Avoid double-padded plush carpet to ease mobility device navigation.
- Provide the same attendee experience on both levels of a two-story exhibit.

- Offer a signer or other auxiliary hearing-impaired apparatus for sound presentations or have a printed copy of the presentation available.
- Run an audio presentation for people with sight problems.
- Arrange touch screen displays at a height to accommodate a person sitting in a wheelchair.

To avoid potential fines by the U. S. Department of Justice, exhibitors must adhere to the ADA rules. Exhibits are not exempt from ADA compliance.

STRUCTURAL INTEGRITY

All exhibit displays should be designed and erected in a manner that will withstand normal contact or vibration caused by neighboring exhibitors, hall laborers, or installation/dismantling equipment, such as fork lifts. Displays should also be able to withstand moderate wind effects that may occur in the exhibit hall when freight doors are open. Refer to local building codes that regulate temporary structures.

It is recommended that all exhibits 20ft by 20ft (6.10m by 6.10m) and larger require a drawing, plans or renderings, preferably digital, to be submitted to the Organizer, and to the show's Official Services Contractor for approval.

Exhibitors should ensure that any display fixtures such as tables, racks, or shelves are designed and installed properly to support the product or marketing materials to be displayed.

FLAMMABLE AND TOXIC MATERIALS

All materials used in display construction or decorating should be made of fire retardant materials and be certified as flame retardant. Samples should also be available for testing. Materials that cannot be treated to meet the requirements should not be used. A flame-proofing certificate should be available for inspection. Exhibitors should be aware of, and must adhere to, all local regulations regarding fire/safety and environment.

Exhibitors should dispose of any waste products they generate during the exhibition in accordance with guidelines established by the U.S. Environmental Protection Agency, or the appropriate government entity in the country the exhibition will be held, and the facility.

HAZARDOUS WASTE

Hazardous waste requires special arrangements to be prepared in advance of event dismantle with either the facility or a local independent disposal company. Exhibitors are responsible for all costs associated with such specialized removal.

STORAGE

Fire regulations in most exhibit facilities prohibit storing product, literature, empty packing containers, or packing materials behind back drapes or under draped tables. In most cases, however, exhibitors may store a limited supply of literature or product appropriately within the booth area, as long as these items do not impede access to utility services, create a safety problem, or look unsightly.

ELECTRICAL

Every exhibit facility has different electrical requirements and rules regarding who is permitted to provide equipment and labor; however, minimum guidelines are suggested:

- All 110-volt wiring should be grounded three-wire.
- Wiring that touches the floor should be “SO” cord (minimum 14-gauge/three-wire) flat cord, which is insulated to qualify for “extra hard usage.” It is particularly important for exhibitors to use flat electrical cord in under-carpet installations.
- Cord wiring above floor level can be “SJ” which is rated for “hard usage.”
- Using zip cords, two-wire cords, latex cords, plastic cords, lamp cords, open clip sockets, and two-wire clamp-on fixtures is not recommended and is often prohibited. Cube taps should be prohibited.
- Power strips (multi-plug connectors) should be UL approved, with built-in over-load surge protectors.
- Local code commonly requires access to electrical cords and connections along the back wall of exhibit booths; typically, the back 9 inches of the space should remain accessible for this purpose. (This would apply to all booth types with a back wall.)

To better understand electrical at exhibitions, see the CEIR article [Demystifying Electrical Services for the Exhibitor](#).

LIGHTING

It is important to remember that lighting issues need to be identified as early as possible during the move-in process so they can be addressed and corrected while the necessary equipment is still available on the show floor and booths can be accessed.

Exhibitors should adhere to the following suggested minimum guidelines when determining booth lighting:

- No lighting, fixtures, lighting trusses, or overhead lighting are allowed outside the boundaries of the exhibit space. Exhibitors intending to use hanging light systems should submit drawings to the Organizer for approval.
- Lighting should not project onto other exhibits or exhibition aisles. Lighting, including gobos, should be directed to the inner confines of the booth space.
- Lighting that is potentially harmful, such as lasers, ultraviolet lights or flashing or strobe lights that can trigger photosensitive epilepsy should comply with facility rules and be approved in writing by the Organizer.
- Lighting that spins, rotates, pulsates, and other specialized lighting effects should be in good taste and not interfere with neighboring exhibitors or otherwise detract from the general atmosphere of the event.
- LED lights can be very bright yet generally generate less heat.
- Currently, some convention facilities are not allowing certain types of quartz halogen lighting fixtures in exhibits due to potential fire hazards.
- Reduced lighting for theater areas should be approved by the Organizer, the utility provider, and the facility.

DEMONSTRATIONS

As a matter of safety and courtesy to others, exhibitors should conduct sales presentations, product demonstrations, press conferences and other media events in a manner which assures all exhibitor personnel and attendees of such in-booth events are within the contracted exhibit space and not encroaching on the aisles or neighboring exhibits. Any queue lines formed for exhibitor customer interaction must also be contained within the booth footprint. It is the responsibility of each exhibitor to arrange displays, product presentation, audio visual presentations, and demonstration areas to ensure compliance with all other previously listed rules and regulations. Exhibitors should be aware of, and adhere to, local regulations regarding fire/safety and environment.

Special caution should be taken when demonstrating machinery or equipment that has moving parts, cooking equipment with an open flame, or any product that is otherwise potentially dangerous. Exhibitors should establish a minimum setback of 3ft (.91m) and/or install hazard barriers as necessary to prevent accidental injury to spectators. Additionally, demonstrations should only be conducted by qualified exhibitor personnel. Many organizers ask that demonstration plans be submitted for approval.

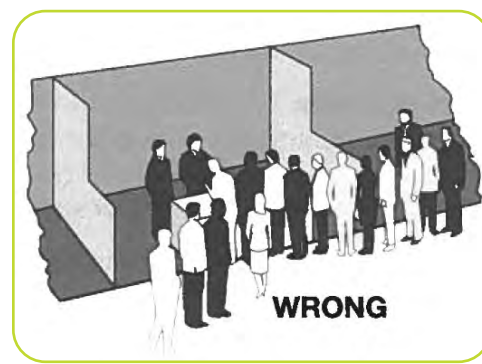
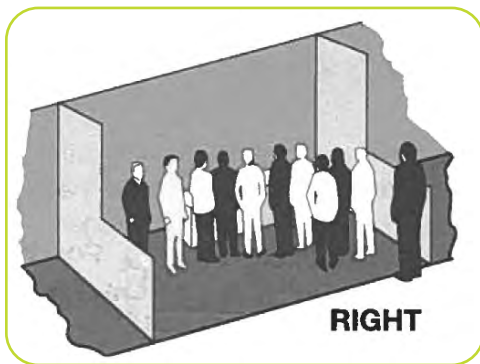

SOUND/MUSIC

In general, the use of sound equipment in booths is permitted as long as the noise level does not disrupt the activities of neighboring exhibitors. Speakers and other sound devices should be positioned to direct sound inward (to be contained within the booth) rather than outward (toward aisles and other exhibitor booths). Generally, sound and noise should not exceed 85 decibels when measured from the aisle immediately in front of a booth. If an exhibitor or attendee is standing within ten feet of an exhibitor's booth and cannot carry on a normal voice-level conversation, the noise source is too loud. (Refer to the U.S. Occupational Safety and Health Act [OSHA] at www.osha.gov for more information.)

Exhibitors should be aware that music played in their booths, whether live or recorded, may be subject to laws governing the use of copyrighted compositions. Authorized licensing organizations, including but not limited to [ASCAP](http://www.ascap.com), [BMI](http://www.bmi.com) and [SESAC](http://www.sesac.com), collect copyright fees on behalf of composers and publishers of music. It is the exhibitors' responsibility to be informed of copyright laws and submit fees to the appropriate organizations.

VEHICLES (FOR BOTH GAS AND ELECTRIC VEHICLES)

Rules for display vehicles vary widely depending on the facility and local fire and safety regulations. Compliance with fire, safety, the U.S. Americans with Disabilities Act (ADA), and other city, county, federal, and provincial government requirements is the responsibility of the Organizer.

Important Note: Always check with local exhibition service contractors and/or the facility for all requirements regarding display vehicles.

Below are a few common examples of display vehicle regulations:

- Display vehicles must have battery cables disconnected and taped, and alarm systems deactivated.
- Fuel tank openings shall be locked or sealed in a manner to prevent escape of vapors through filler caps.
- Vehicles shall be limited in the amount of fuel that can remain in the tanks; specific amounts vary but one example is no more than one-quarter the tank capacity or a maximum of five gallons of fuel, whichever is less.
- Fueling or de-fueling of vehicles on the facility premises is prohibited.
- Once placed, display vehicles may not be started or moved without the approval and direction of show management.
- Auxiliary batteries not connected to engine starting system may remain connected. External power is recommended for demonstration purposes. No battery charging is permitted inside buildings.
- Combustible/flammable materials must not be stored beneath display vehicle. There may be no leaks underneath vehicles.
- It is not recommended that Organizers hold or take possession of display vehicle keys during the event. However, it is recommended that an official policy be established for the handling of vehicle keys which might include identifying booth contacts with mobile numbers should vehicles need to be moved in an emergency or some other unforeseen situation. Need to get guidelines for placing, displaying electric vehicles.
- Check with your facility regarding any weight load limits.
- Show organizers should request information from exhibitors in advance of the show if they are bringing in a vehicle Usually 45 days is the standard.
- Vehicles can only be moved to and from their booth outside show hours and under the supervision of show management and/or Official Service Contractor depending on the rules in the building.

ADVISORY NOTES TO EXHIBITION ORGANIZERS

FIRE EQUIPMENT

Fire hoses, extinguishers, and audible or visual devices for fire alarms should be visible and accessible at all times.

HANGING SIGNS

Although these Guidelines indicate 16ft to 20ft (4.88m to 6.10m) as a maximum height range to the top of the sign, some exhibitions permit other heights, or have no height limit. However, most Organizers do impose height limits. Caution should be exercised so exhibitors will not compete over air space for hanging signs.

Exhibitors should be advised to install “hanging points” at the time of manufacture of the sign or display. It is also advisable to have Hanging Signs labeled and cased separately so that they can be easily identified on-site as they usually must be installed before other exhibit construction can begin.

Recommend checking with facilities regarding some areas of exhibit hall that may not have points available to alert exhibitors.

HARDWALL BOOTHS

Exhibitions that provide Hardwall Booths should specify if these structures can be used for display and attaching products.

PERIMETER OPENINGS

Local fire and/or facility regulations may require larger exhibit booths to have a certain number of openings within the perimeter walls for safe egress. Regulations vary with each location, but one example would be to provide, at a minimum, one 6ft (1.83m) wide opening every 30ft (9.14m).

PIPE AND DRAPE

These are commonly used at exhibitions and events in the United States to define exhibit space. Organizers also may note which size booths and configurations will be provided with pipe and drape. Organizers often include in their rules and regulations that this equipment is not intended as a display fixture. Therefore, product and signs should not be attached or affixed. Measurements of booths must allow for size of pipe on sides and back.

PRODUCT HEIGHT

Some exhibitors have products that exceed display height restrictions. Organizers should establish guidelines for displaying such products. For example, some exhibitions or events require that these exhibitors reserve only perimeter space. Products exceeding height restrictions for Islands and Peninsulas are usually permitted, providing they are displayed in operating mode, and the names and logos, etc. on the product are as it is sold. NOTE: Any special height variances allowed should apply only to those products represented, produced or manufactured by the exhibitor and would not apply to ancillary display or marketing items (such as promotional flags, signs, etc.).

HEIGHT VARIANCES

Height Variances may be issued for all types of booths. However, in a Linear Booth, the back side of any structure over 8ft (2.44m) must be free of trademarks, graphics and/or logos. Tall flags or markers on the front aisle of Linear Booths are prohibited. Pop up tents or canopies may be allowed but must follow all local fire and facility regulations.

ENVIRONMENTAL RESPONSIBILITY

Exhibitions and events, by their very nature, create waste. Properly managed, exhibitions and events can recycle excess materials and supplies in useful and meaningful ways, and they can do so using methods that result in minimized impact on the environment. Exhibits should utilize recycled, renewable and energy efficient materials whenever possible. Exhibitors planning to dispose of, or leave behind, any property from their booth must make arrangements with the Official Services Contractor for disposal and all appropriate and applicable fees will apply.

APPENDIX



White Paper: Evaluating and Implementing Cubic Content into Linear Exhibit Space

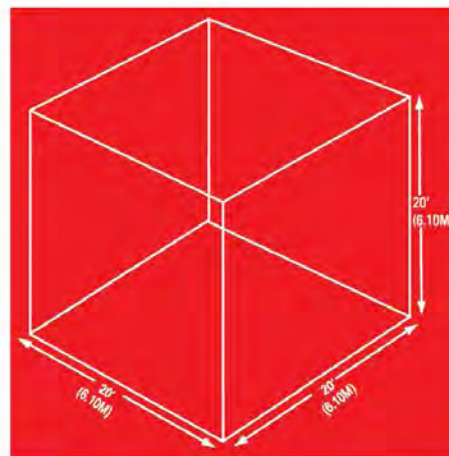
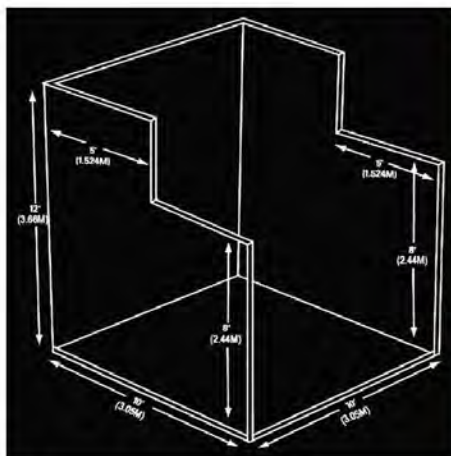
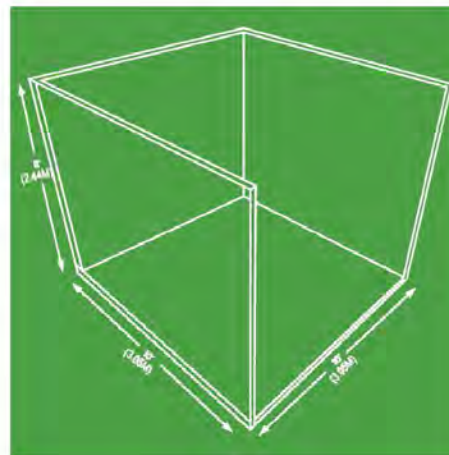
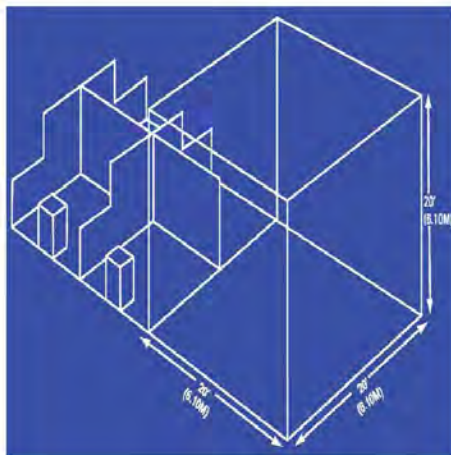

WHITE PAPER: EVALUATING AND IMPLEMENTING CUBIC CONTENT INTO LINEAR EXHIBIT SPACE

Table of Contents

Introduction.....	2
Research.....	2
Use of Cubic Content.....	2
International Exhibitions vs. US Exhibitions – Display Guidelines.....	3
Reasons to Consider.....	3
Key Responses from Exhibition Organizers Allowing Cubic Content (11 of 33 responses) – In Their Own Words.....	3
Exhibition Organizers Who Do Not Allow Cubic Content (22 of 33 responses) – In Their Own Words.....	4
Hardwall, Fabric, Portable, Modular, Table Top Displays, Pipe & Drape – Living Together.....	5
Floor Plan Layouts to Accommodate Linear Cubic Content Booths – Special Layouts.....	5
Cubic Content for Products.....	5
Equipment/Display Material: The following is an example of display rules for a specific type of item;.....	5
Perspective.....	5
Sample of Cubic Content Display Guidelines (Provided by Messe Frankfurt).....	6

WHITE PAPER: EVALUATING AND IMPLEMENTING CUBIC CONTENT INTO LINEAR EXHIBIT SPACE

Introduction

IAEE presents the following white paper as an academic briefing without recommendation regarding the use of full cubic content for linear exhibit space and its potential impact on the exhibitions and events industry. As it pertains to exhibition booths, cubic content is a unit of measurement allowing display materials and products to occupy 100 percent of the exhibit space purchased, regardless of sightlines, up to a height established by the exhibition's rules.

It is the responsibility of the exhibition organizer to establish rules to best achieve the goals for its exhibition. Based on the nature of the exhibition, it is ultimately the choice of the exhibition organizer whether to allow use of full cubic content in linear exhibit space, or to observe the line-of-sight set-back rule. IAEE's publication, *Guidelines for Display Rules and Regulations* is intended to be viewed as guidelines, and not rules.

This white paper addresses the dynamics involved in the likelihood that as more international exhibitors participate in U.S.-based events, the expectations for cubic content availability will also increase. Thus the questions are:

- How can this new trend best be met, if at all?
- What methods might be employed to allow dual usage of both cubic content booths and line-of-sight booths?
- What are the advantages/disadvantages of doing so?

Further, many exhibitions and events today already allow for cubic content, primarily due to the nature of the industry sector it serves. It is prudent for the exhibition organizer considering cubic content for their exhibitions to review the concerns, advantages and disadvantages prior to putting cubic content guidelines into practice.

Research

IAEE requested feedback and input from its members from which 10 responses were received. Task force members then conducted telephone interviews with 35 show organizers whose organizations represent various industry sectors. Additional information was gathered through comments from the EDPA LinkedIn online discussion group. The responses are reflected in this document as to the advantages, disadvantages, international exhibitors, etc.

Use of Cubic Content

Under the current IAEE *Guidelines for Display Rules and Regulations*, cubic content, as it pertains to exhibitions and events, generally allows an exhibitor utilizing island space (a minimum of four 10' x 10' booths, open on four sides), to occupy 100 percent of the island space with both product and display materials. Regarding linear booths, it states "It is common at certain types of exhibitions to eliminate the line-of-sight requirement for Linear, End-Cap, and Peninsula Booths that back up to Linear Booths. This permits exhibitors to utilize the full cubic content of the booth." A Split Island Booth may also be allowed to utilize full cubic content of the booth when it backs up to another Split Island Booth.

The IAEE Guidelines for Display Rules and Regulations are not rules. Therefore some organizers have revised the Guidelines to fit their own needs as it pertains to cubic content and other guidelines. For instance, some heavy equipment exhibitions, for safety purposes, may require a setback of nine to twelve inches from the aisle line to prevent tripping. Others may require a 20 percent sightline of island booths.

For the purpose of this document we will restrict comments to construction and use of linear space. Many organizers today are permitting use of cubic content in linear booths because either their exhibitors find cubic content to be beneficial to their display, or because they want international exhibitors to feel welcome. It also reduces the need to police exhibits to enforce setback rules. The IAEE *Guidelines for Display Rules and Regulations* do not suggest cubic content should be implemented for linear booths; however cubic content in a linear booth is acceptable when the organizer has advantageous reasons to allow it. Prior to putting cubic content into practice, exhibition organizers must be proactive in communications with exhibitors, and understand the effect it will have on the exhibition. This document contains feedback from show organizers who allow use of cubic content in linear booths and those who do not. The intent is to assist a show organizer in making the best decision for their show.

WHITE PAPER: EVALUATING AND IMPLEMENTING CUBIC CONTENT INTO LINEAR EXHIBIT SPACE

International Exhibitions vs. US Exhibitions – Display Guidelines

Most European exhibitions and other countries allow the use of cubic content. Larry Kulchawik, senior vice president of 3D Exhibits, Inc., says, "Not all rules, styles, and customs are the same from country to country ... this is only one part of the country differences in trade show marketing, but a big one."

Cubic Content for linear booths in the U.S. is not as popular as it is in other countries, but more and more U.S. organizers are finding it necessary to allow cubic content in linear booths for the sake of attracting and accommodating international exhibitors. Many U.S. exhibitions have government-sponsored international pavilions that typically are island spaces, back-to-back booths or booths facing each other with an aisle between. Depending on the type of space, these pavilions often are allowed to utilize full cubic content in the U.S.

International exhibitors occupying linear space sometimes bring in their own display house to help them conform to the U.S. display guidelines. The difference between U.S. display regulations and their country's regulations, such as cubic content, square meters and square feet can be perplexing to a show's new international exhibitor.

"Some clients want to capture the clientele in an enclosed stand and generally these clients have invitations in advance of the show so they have an appointment. Others prefer to enclose their stand to immerse the potential viewers in an experience. What better way than to take away the distraction of the other stands. Those that choose the open feel are trying to educate potential customers or get their corporate identity out there for everyone to see," Mac Kleitka, project manager of Creative Solutions Group.

Reasons to Consider

Aside from accommodating international exhibitors, or the belief that cubic content is more conducive to certain types of product displays or experiences, the fact is, today's exhibitors want more return on their investment. Many exhibitors feel they should be able to utilize all the space they have paid for without a five-foot setback rule. Exhibitors want to display their products in a structure or setting that is best suited toward maximizing their investment. Ultimately it is the show organizer who will decide whether cubic content is a practical display regulation.

Key Responses from Exhibition Organizers Allowing Cubic Content (11 of 33 responses) – In Their Own Words

"With the exception of one or two shows, all are cubic content. We have utilized cubic content for years and feel it gives our customers more value for their money by allowing them to use more of their space. The one or two shows we do not use cubic content on, we rarely get any push back and those shows do have an international presence. What feedback we do get (which is minimal) is typically centered on obstructions from a neighboring booth. These objections often come from those who have not read our exhibitor manual where cubic content is prominently addressed."

"We have already implemented it for all nine shows we run in North America. Linear Booth Use of Space: Shows allow exhibitors full "Cubic Content" use of the exhibit space. Therefore, you are allowed to place displays or materials at the full eight foot (2.44m) height throughout the entire width and depth of your exhibit space. Perimeter Booth Dimensions and Use of Space: All guidelines for Linear Booths apply to Perimeter Booths except that the maximum back wall height is 12ft (3.66m). There were a few complaints initially, but they were a minority and have now stopped. We make sure to explain the rules clearly to new exhibitors and to remind everyone frequently. We implemented this because it made it more consistent for our international exhibitors from around the world, and eliminated the majority of our set-up issues onsite (which are mostly due to sightline issues)."

"Our exhibition allows for the use of the cubic content of exhibit spaces. The feedback has been overwhelmingly positive. Most companies exhibit in some international shows. They appreciate the consistency of having the same rules and also see the common sense approach to allow exhibitors to use all their space. And, since it is fully implemented, it is fair for all. We allow cubic content in all areas."

WHITE PAPER: EVALUATING AND IMPLEMENTING CUBIC CONTENT INTO LINEAR EXHIBIT SPACE

"We do have an abbreviated cubic content rule for islands and split islands. The entire cubic content of the space may be used up to the maximum allowable height; however exhibitors must follow the line-of-sight guidelines (20 percent) listed above. The line-of-sight guideline referenced above states: All booths regardless of size or type should be designed in such a way so as to eliminate line-of-sight obstructions from one exhibit to the next. A solid wall or banner between an island or split-island booth and a row of linear booths (particularly along the perimeter) is inappropriate. This is particularly important along shared walls and borders between linear and split-island exhibits. If you are planning a hardwall installation that could obstruct the view to neighbors' booths, a booth variance form and schematic must be submitted for review. **NEW** – All island booths regardless of size should allow 20 percent of visibility on all sides excluding the shared back wall. Examples: 20' x 20' island: each side of the booth must have visibility for a minimum of 4'. 30' x 40' island: the 30' sides of the booth must allow visibility for a minimum of 6'; the 40' sides of booth must allow visibility of 8'. Exhibitors may use Plexiglas or similar material to create a wall that will allow for line-of-sight from one booth to the next.

The linear 10' x 10's have a harder time understanding that they must follow the standard IAEE rules allowing for no product or displays over 4' tall in the front half of the booth. We have had this guideline in place for about three years now, but have always allowed them to receive a variance if their theaters, meeting rooms, etc., did not allow for this amount of line-of-sight. However, at this time we are telling exhibitors that we will be enforcing the rule for the 2012 show. Our exhibitor advisory committee requested that we begin enforcing the rule for next year."

"Exhibitors are to show respect for fellow exhibitors and fire marshal rules must be met – island exhibits and linear."

"Yes, exhibits can be closed on three sides for linear booths, totally closed in for islands."

"We approve on a request-only basis. Show is less than 10 percent cubic content exhibits."

"We will allow cubic content for booths that are against an outside wall that do not have adjacent booths/neighbors."

Exhibition Organizers Who Do Not Allow Cubic Content (22 of 33 responses) – In Their Own Words

"We do not like the reduced sightlines that this would create."

"We feel it is important to protect sightlines. We spend time communicating with them (international exhibitors) to try to set expectations before they arrive for the show."

"Most overseas exhibitors want to comply with line-of-sight rules when they exhibit in the U.S; however, some request cubic content and those requests are granted. No complaints from neighbors."

"While the cubic approach to booth content may eliminate some issues and policing, we believe in the line-of-sight good neighbor policy. If exhibitors want to use cubic content for their booth, they can purchase an island."

"Unfair to our small exhibitors that depend on a fair sightline into their booth."

Note: All other exhibition organizers interviewed said they use the line-of-sight in the *IAEE Guidelines for Display Rules and Regulations*.

WHITE PAPER: EVALUATING AND IMPLEMENTING CUBIC CONTENT INTO LINEAR EXHIBIT SPACE

Hardwall, Fabric, Portable, Modular, Table Top Displays, Pipe & Drape – Living Together

There are many different types of displays used in exhibitions. If the organizer chooses to allow cubic content in linear booths, the organizer needs to be aware of the responsibility to communicate the rules clearly to all exhibitors so there are no surprises on site. A portable exhibit may only extend five feet out from the backwall but its neighbor may have hardwall at eight-foot height out to the aisle line. The portable exhibit must be aware the sightline will be impacted and the hardwall exhibitor must be sure the backsides of the panels are finished. This is true with all exhibits in a linear space cubic content exhibition. If the rules allow for cubic content in linear spaces, then it is a fair environment for all to choose how they wish to use that space; but communication is key to a smooth operation.

It is rare to expect a U.S. exhibition or its general service contractor, to provide hardwall for all exhibitors; however, exhibitions using all hardwall do exist in the U.S.

Floor Plan Layouts to Accommodate Linear Cubic Content Booths – Special Layouts

None of the show organizers interviewed indicated a need for a split floor plan, i.e., certain areas of the floor are designated for linear cubic content booths.

Cubic Content for Products

Some exhibition organizers allow products to exceed the four-foot high rule five feet in from the aisle line. Others do not and strictly enforce the sightline setback. The types of products displayed may determine whether an organizer chooses to permit products only (not booth structure) to occupy the cubic content of a linear booth. However, for example, if the product is banner stands that are eight feet or 10 feet tall, a row of banner stands at the aisle line may be very intrusive to a neighbor. On the other hand, a piece of machinery that is six feet tall may not cause a major problem. Exceptions may also depend upon the size of a booth such as 10' by 20' versus 10' by 10'. Under certain circumstances, an organizer may prefer to make the exception a variance, subject to show management review and approval. This option provides the organizer more control if product is an exception to the set-back guidelines.

Equipment/Display Material: The following is an example of display rules for a specific type of item:

- **SPECIAL PROVISIONS:** Pedestals, tables, racks, shelves, risers and similar display equipment may not exceed 42" in height when positioned more than 5' from the back wall of a single-aisle exhibit booth space or the center line of a three-aisle exhibit booth space, unless the same company occupies 8' of exhibit booth space on both sides of the unit or units. The maximum height for such items under these circumstances, including the product being displayed, is 66". Free-standing units, including those intended to be the focal point in an exhibit, may not exceed 42" in height when placed more than 5' from the back wall of the exhibit booth space unless the same company occupies 8' of exhibit booth space on both sides of the unit or units. The maximum dimensions for such items under these conditions are 8' high x 32" wide x 32" deep.

Perspective

It is inevitable that exhibition organizers will have varying thoughts and opinions about allowing exhibitors to have full use of the cubic content space within their linear booth. Just as there are many different opinions as to whether end cap booths are permissible in floor plan layouts due to the somewhat difficult situations they often times create, the exhibition organizer must make the determination as to what is best for their exhibition.

It is often wise to consult with an exhibition's Exhibits Advisory Board. Alternatively, an organizer may consider conducting a focus group of the exhibition's exhibitors to determine their interest and gain their feedback.

A linear space exhibitor utilizing cubic content for the first time may also experience some higher costs. If they bring a hardwall display that reaches 8' high for three sides of their exhibit, when in the past they utilized a fabric display, obviously their labor, shipping and drayage costs will be higher. However, that is the decision of the exhibitor if the exhibition organizer is allowing cubic content for linear displays and the exhibitor chooses to take advantage of the space in this fashion.

WHITE PAPER: EVALUATING AND IMPLEMENTING CUBIC CONTENT INTO LINEAR EXHIBIT SPACE

Sample of Cubic Content Display Guidelines (Provided by Messe Frankfurt)

Linear Booth

Linear Booths have only one side open to an aisle and are generally arranged in a series along a straight line. They are also called “in-line” booths. Floor covering is required in all rented space.

Dimensions

For purposes of consistency and ease of layout and/or reconfiguration, floor plan design in increments of 10ft (3.05m) has become the de facto standard in the United States. Therefore, unless constricted by space or other limitations, Linear Booths are most commonly 10ft (3.05m) wide and 10ft (3.05m) deep, i.e. 10ft by 10ft (3.05m by 3.05m), with a maximum back wall height limitation of 8ft (2.44m).

Use of Space

Messe Frankfurt Shows allow exhibitors full “Cubic Content” use of the exhibit space. Therefore, you are allowed to place displays or materials at the full 8 ft. (2.44m) height throughout the entire width and depth of your exhibit space.

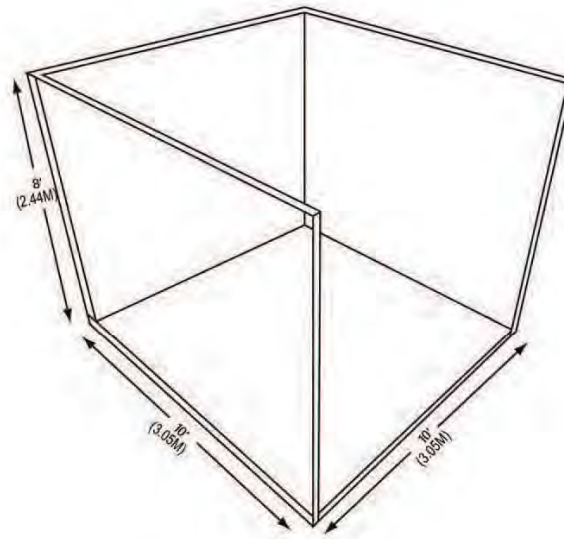

LINEAR BOOTH (10' X 10') (3.05m x 3.05m)

Corner Booth

A Corner Booth is a Linear Booth exposed to aisles on two sides. All other guidelines for Linear Booths apply.

WHITE PAPER: EVALUATING AND IMPLEMENTING CUBIC CONTENT INTO LINEAR EXHIBIT SPACE

Sample of Cubic Content Display Guidelines (Provided by Messe Frankfurt)

Perimeter Booth

A Perimeter Booth is a Linear Booth that backs to an outside wall of the exhibit facility rather than to another exhibit. Floor covering is required in all rented space.

Dimensions and Use of Space

All guidelines for Linear Booths apply to Perimeter Booths except that the maximum back wall height is 12ft (3.66m).

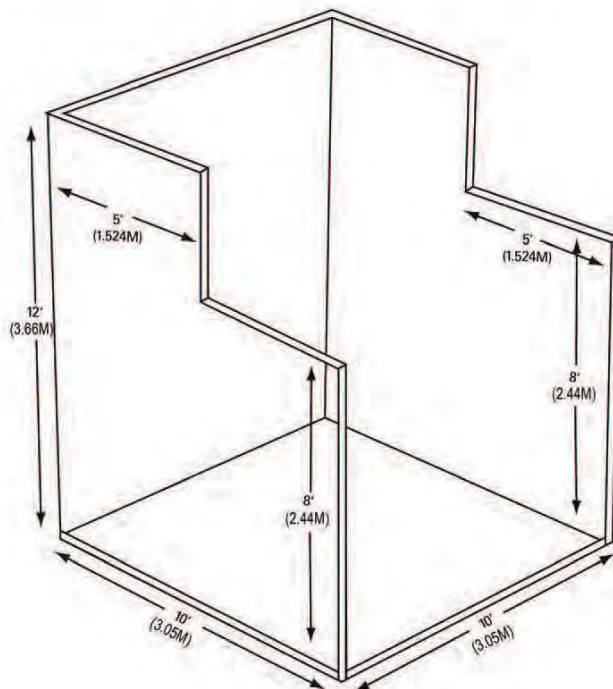

PERIMETER BOOTH (10' X 10') (3.05m x 3.05m)

WHITE PAPER: EVALUATING AND IMPLEMENTING CUBIC CONTENT INTO LINEAR EXHIBIT SPACE

Sample of Cubic Content Display Guidelines (Provided by Messe Frankfurt)

Peninsula Booth

A Peninsula Booth is exposed to aisles on three (3) sides and is a minimum of 20' x 20' (6.10m) in size. Floor covering is required in all rented space.

Dimensions

A Peninsula Booth is usually 20' x 20' (6.10m x 6.10m) or larger. Twenty feet (20') (6.10m), including hanging signage, is the maximum height allowed throughout the booth space. The connecting wall between the peninsula booth and any neighbors must be "finished off" (clean and presentable to visitors) on the side facing the connecting neighbors.

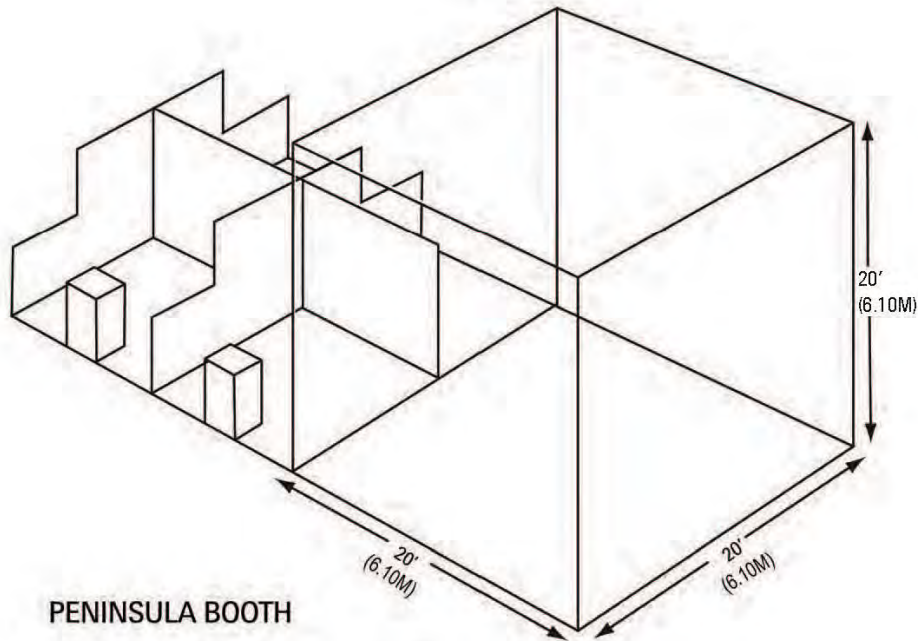

WHITE PAPER: EVALUATING AND IMPLEMENTING CUBIC CONTENT INTO LINEAR EXHIBIT SPACE

Sample of Cubic Content Display Guidelines (Provided by Messe Frankfurt)

Island Booth

An Island Booth is any size booth exposed to aisles on all four sides. Floor covering is required in all rented space.

Dimensions

An Island Booth is typically 20' x 20' (6.10m x 6.10m) or larger.

Use of Space

The entire cubic content of the space may be used up to the maximum allowable height of twenty feet (20') (6.10m), including any hanging signage.

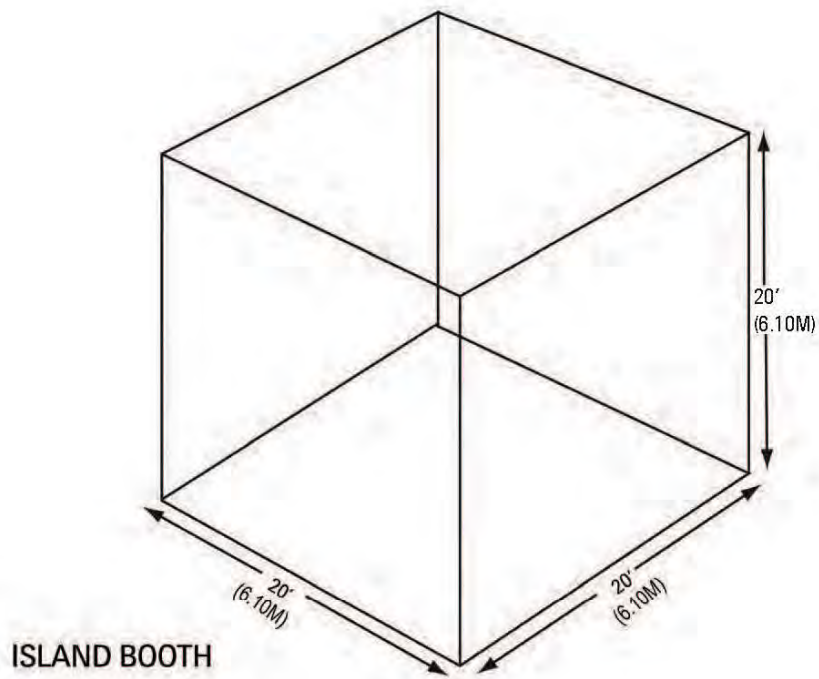

WHITE PAPER: EVALUATING AND IMPLEMENTING CUBIC CONTENT INTO LINEAR EXHIBIT SPACE

IAEE appreciates the efforts of the Cubic Content Task Force in developing this White Paper:

Carol Fojtik, CEM, Chair
Robert C. Brice
Thomas C. Corcoran
Kevin Johnstone
Martin Moggre, CEM
Pamela Kay Pietrok
Paul Prince, CEM
Chuck Schwartz, CEM
Barry Siskind
Julie Anderson, CEM, CAE, Staff Liaison
Terri Phillips, Staff Assistant

Additional appreciation goes to the following organizations that contributed relevant content for this white paper.

American Society of Mechanical Engineers
Association of Equipment Manufacturers
Corcoran Expositions
Distribution Solutions Conference
ExpoNation LLC
Home Builders Show
IMN Solutions
InfoComm
International Association of Fairs and Expositions
Messe Frankfurt
National Association of Broadcasters
National Restaurant Association
Reed Exhibitions

IAEE EXTENDS A SPECIAL THANK YOU TO THE FOLLOWING VOLUNTEERS FOR THEIR INPUT:

Russell Wingard, CEM

Vice President, Client Solutions
Freeman

Frank Sheridan

Principal
ExpoAnswers, Inc.

2023 MATSO Council

John Rozum, Chairperson

Senior Director, Ag & Utility Exhibitions and Events
Association of Equipment Manufacturers

Lisa Malikow, Vice Chairperson

Senior Vice President, Event Operations & Programming
National Restaurant Association Show/Winsight Media

Mark Bogdanský, Immediate Past Chairperson

Vice President, Meetings & Events
Auto Care Association

Melodie Anderson, CEM, DES

Director of Meeting and Exhibit Experiences
Institute of Food Technologists

Kate Hawley, CEM

Senior Manager, WEFTEC Exhibition Sales
Water Environment Federation

Iain Mackenzie, CEM, CMP

Vice President, Meetings & Events
International Sign Association

Nath Morris, CEM

President, Expo
U.S. Poultry & Egg Association

Merideth Newman, CEM

Director, Expositions
The Association for Packaging and Processing
Technologies – PMMI

Gary Thuro

Chief Marketing & Sales Officer
RE+ Events

Ellen Tucker, CAE, MAS

Vice President of Revenue & Expositions
PPAI: Promotional Products Association International

Jess Tyler, CEM

Chief Revenue and Experience Officer at MJBiz
A division of Emerald X, LLC

T3 EXPO INFORMATION

Show Information

Location

Fort Worth Convention Center
1201 Houston Street
Fort Worth, TX 76133

Exhibit Hall

Halls A, B, C

Booth Package

Each 10' x 10' Exhibitor Booth includes:

- 8' High Back Wall Drape
- 3' High Side Rail
- (1) Booth ID Sign (44"w x 7"h)
- (1) Wastebasket

Show Colors

- Drapes – Grey
- Side Rails – Grey
- Aisle Carpet – Tuxedo

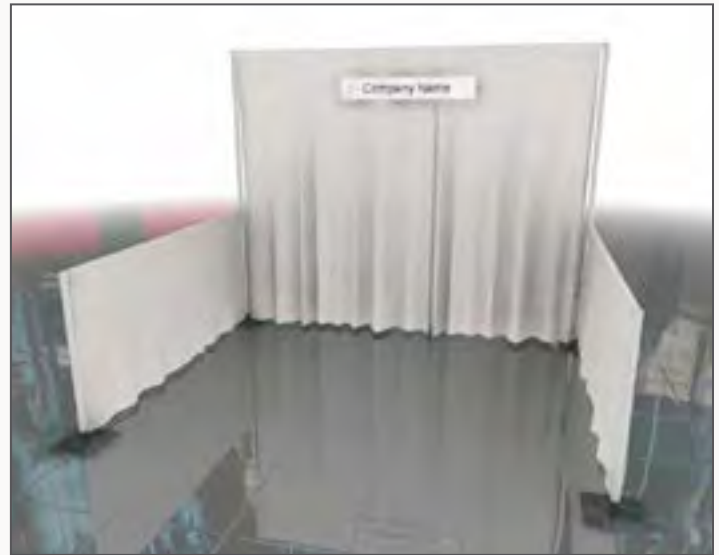

The booth space is carpeted. Floor covering is not required but may be ordered in this kit or at order.t3expo.com.

Exhibitor Move-in	Exhibit Hours	Dismantle/Move-out	Carrier Check-in
Monday, November 18 8:00 am – 8:00 pm	Tuesday, November 19 12 noon – 5:30 pm	Wednesday, November 20 3:30 pm – 10:00 pm	Thursday, November 21 By 8:00 am
Tuesday, November 19 8:00 am – 11:00 am	Wednesday, November 20 9:30 am – 3:30 pm	Thursday, November 21 8:00 am – 10:00 am	–

PLEASE NOTE: Hours are subject to change. Colors and style may vary upon availability.

Important Dates & Deadlines Checklist

Friday, October 11, 2024.....	Presta™ Rental Exhibit Package Order Deadline
Friday, October 11, 2024.....	Receiving at Advance Warehouse Begins
Friday, October 18, 2024	Presta™ Rental Exhibit Package Artwork Submission Deadline
Friday, October 18, 2024	Drayage Order & Discount Deadline
Friday, October 18, 2024	Exhibitor Appointed Contractor Form Deadline
Friday, October 18, 2024	FWCC Telecom Service Orders Advance Discount Deadline
Friday, October 18, 2024	FWCC WiFi Service Orders Advance Discount Deadline
Friday, October 25, 2024	Presta™ Rental Exhibit Package Artwork Approval Deadline
Friday, October 25, 2024	T3 Service Orders Advance Discount Deadline
Friday, October 25, 2024	Custom Furniture Advance Discount Deadline
Sunday, October 27, 2024.....	Electrical & Plumbing Services Advance Discount Deadline
Friday, November 1, 2024	Floral Service Orders Advance Discount Deadline
Friday, November 8, 2024	Last Day for Advance Shipments to Arrive without Surcharges
Monday, November 18, 2024	Direct Shipments to Show Site May Begin Arriving After 8:00 am
Tuesday, November 19, 2024	All Exhibits Must Be Set by 11:00 am
Thursday, November 21, 2024.....	All Carriers Must Check In by 8:00 am

PLEASE NOTE: There are no Lead Retrieval Devices at this show.

Preshow Checklist

[Please click here to view our Terms and Conditions](#)

Review this entire Service Kit (PLEASE NOTE: Payment is required with all orders)

Arrange in-bound freight/Material Handling

If you or any other vendor are shipping materials to your booth, be sure to choose **Advance** or **Direct Shipping**:

Advance Shipping:

- If you ship to the Advance Warehouse, your freight will be guaranteed to be in your booth for the first day of set up.
- Be sure to look at the Late to Warehouse date. Freight being received after the date will incur a surcharge.
- The Advance Warehouse is not able to accept loose unpackaged pieces. Shipping crates, fibers, cartons, hanging signs, carpet, padding and pallets are acceptable. Due to circumstances of timing or facility availability beyond the control of T3 Expo, this may result in an overtime surcharge: please refer to the Material Handling form.

Direct Shipping:

- If you ship direct to show site, note the dates that shipments can be received. Shipments arriving before these dates may be refused.
 - PLEASE NOTE: Any freight arriving on a Saturday, Sunday or before 8:00 am and after 4:30 pm Monday – Friday or observed local union holidays will incur an overtime surcharge.
2. Check the show timing to gauge which shipping option meets your scheduling parameters and make note of handling surcharges (overtime, off target, late/early to warehouse etc.).
 3. Fill out the Material Handling form in the Service Kit to estimate your costs and submit it with your payment.
 4. Label your freight correctly with your company name, booth number, event/show name and address listed in the Service Kit. Shipping label forms are provided in the Service Kit.
 5. Bring all copies of shipping documents with tracking numbers to show site.

Order rental booth structure and/or option, if applicable

- Please choose the appropriate option and/or configuration of your booth structure.

Order graphics/signage and submit artwork, if applicable

- See the Print Production Artwork Requirements page in this Service Kit for format information and submission details.

Order booth furnishings/accessories, if applicable

- There are forms in this Service Kit with many options to enhance the look of your exhibit. Discount price deadlines are noted on the forms.

Order T3 installation & dismantle labor, and / or submit EAC forms with proof of insurance

- Venues have different union regulations; please review the Labor Guidelines page to determine if hiring labor to set-up / tear down your exhibit properties is needed.
- If using a firm other than the official service contractor, a Notification of Intent to Use EAC form and proof of insurance must be submitted at least (30) days prior to the first day of exhibitor move-in. Without these documents, your EAC will not be allowed to set any exhibits.

Order additional/ancillary services

- There may be forms in this Service Kit for other services such as; accessible storage, sign hanging, custom furnishings, electricity, internet, audio visual, lead retrieval, cleaning, floral or catering.
- Some of these services are provided by vendors other than T3 Expo; be sure to submit forms and payments to the proper vendors. Please make note of ordering discount deadlines.

Submit your order with payment (REQUIRED)

- This will ensure all booth options, graphics, furnishings and accessories are reserved for your event. Orders received without payment cannot be processed. We accept Mastercard, Visa, American Express, company check or wire transfer.

Arrange out-bound freight

- Before the end of your event, be sure to visit the T3 Service Desk to pick up a Material Handling form.
- No Material Handling form will be distributed unless the account is paid in full.
- There will be a show carrier providing air and/or ground shipping options. If you are using your own carrier, you will need to schedule them on your own for a pickup.
- Please note the carrier check-in time on the Show Information page.
- If your carrier does not check-in by the date/time listed, your freight will be re-routed to ship with the show carrier at your expense.

On-site Checklist

Check all freight when you arrive

- Verify that all your shipments have arrived in your booth space. Please check against your shipping documentation before unpacking any freight.

Booth set-up

- If you are using T3 Expo Installation Labor, you must go to the T3 Service Desk to inform us that you are ready for your labor.
- Installation/Dismantle Labor start time is only guaranteed when ordered for 8:00 am.
- Once your booth is set up, tag your empty containers with Empty Stickers which can be picked up at the T3 Service Desk.

Arrange outbound shipping

- Before the end of the event, visit the T3 Service Desk to pick up your Material Handling form(s). You will need a separate Material Handling form for each outbound shipping destination.
- Material Handling form(s) will not be distributed until account is paid in full.
- There will be show carriers on-site for air and ground service.
- If you are using your own carrier, you must schedule them in advance to pick up your shipment(s).
- Note the Carrier Check-in date / time on the Show Schedule form.
- If your carrier doesn't check in by the date/time listed, your freight will be rerouted onto a show carrier at your expense.

Booth freight packed and ready to ship out

- Once your freight is packed and labeled to ship out, you must turn in your Material Handling form(s) at the T3 Service Desk.
- Do not leave your Material Handling form(s) in your booth space or on your freight.
- If you do not turn your Material Handling form(s) into the T3 Service Desk, your shipment may be delayed and/or rerouted to a show carrier.

SHIPPING INFORMATION

Ag Aviation Expo 2024
BOOTH #: _____

Material Handling

Choosing Your Carrier

Please carefully consider your carrier prior to booking your shipment(s) to and from the event. Various carriers are set up to operate on a certain schedule or with limited delivery procedures. Please be sure to review your carrier's policies. Some carriers will not deliver to a loading dock, some deliver without verification or signature of delivery. This may result in delays in delivery or additional fees.

POV (Privately Owned Vehicle): If you are delivering your materials to show site in your own vehicle, there may be Material Handling charges applied. Please refer to the Union Regulations in this kit and plan accordingly. T3 has jurisdiction over the loading dock based on these regulations.

Rate Classifications

Crated: Material that is skidded or in any type of shipping container that can be unloaded at the dock with no additional handling required.

Uncrated: Material that is shipped loose or pad-wrapped, and/or unskidded machinery without proper lifting bars or hooks. The Advance Warehouse is not able to accept loose/unpackaged pieces; shipping crates, fibers, cartons and pallets are acceptable.

Small Package: A shipment of any number of pieces with a combined weight of 1-50 lbs that is received on the same day, from the same shipper and delivered by the same carrier at the same time.

Additional Fees May be Applicable

Late to Warehouse Fee: Shipments arriving after Friday, November 8, 2024 will be charged an additional 30%.

Off Target Fee: If your event has a targeted move in, you must schedule your delivery within your target time. If your freight is received Off Target, there will be an additional fee of 30% of your Material Handling costs for that shipment.

T3 has a blended rate so there is no overtime.

Based upon the Material Handling rates quoted, a 30% surcharge per pound for each occurrence will apply if:

- Shipments are received on overtime.
- Your advance shipment to the warehouse is received during straight time hours, but due to scheduling beyond T3 Expo's control, is moved into show site on overtime.
- Shipments are loaded out on overtime.

Outbound Shipping

- A Material Handling form MUST be filled out for any shipment leaving the Expo Hall. These forms can be picked up at the T3 Expo Service Desk. All accounts must be settled prior to requesting this form.
- Once you have filled out the Material Handling form and ALL of your booth materials are packed, labeled, and ready for shipping, please return the completed form to the T3 Expo Service Desk – **DO NOT LEAVE THIS FORM IN YOUR BOOTH SPACE.**

Carrier Check-in: All carriers must be checked in no later than Thursday, November 21, 2024 by 8:00 am. If prior arrangements have not been made, the official show carrier will be on-site to coordinate or re-route shipments.

UPS or Federal Express: To use these carriers, you MUST have their shipping labels for each piece and schedule your pick up. Without these, your freight will NOT be picked up by either. If there is a Business Center on the property, it is recommended that you bring your items there.

PLEASE NOTE: There may be an additional fee from the facility for this service.

Advance Shipments to T3 Expo Warehouse

Advance Shipments will be received at the Advance Warehouse beginning on Friday, October 11, 2024. Shipments arriving prior to this date may be refused.

Crated or Uncrated

Shipment Weight x \$2.59/lb = \$ _____

Small Package Shipment - Total Shipment Weight 50 lbs or less

Small Package Shipment x \$75.00 ea. = \$ _____

Material Handling Estimate \$ _____

Direct Shipments to Show Site

Direct shipments will be received starting on Mon., November 18, 2024. Shipments that arrive prior to this date may be refused by the Fort Worth CC as T3 Expo will not have possession of the venue prior to this date and time. Deliver to the loading docks on Commerce St.

Crated or Uncrated

Shipment Weight x \$2.59/lb = \$ _____

Small Package Shipment - Total Shipment Weight 50 lbs or less

Small Package Shipment x \$75.00 ea. = \$ _____

Material Handling Estimate \$ _____

Shipping Addresses

Advance Shipments to T3 Expo Warehouse

Address

To: (Exhibiting Company Name)
(Booth #)

For: **Ag Aviation Expo 2024**

c/o: T3 Expo
c/o: TForce Freight c/o Crane Cartage LLC
4050 Valley View Ln, Ste 100
Irving, TX 75038

Information

Advance shipments will be accepted beginning on Friday, October 11, 2024 through Friday, November 8, 2024 between the hours of 8:00 am – 4:00 pm.

Shipments received after Friday, November 8, 2024 will be charged an additional 30% per pound.

Please note when overtime rates apply as stated on Material Handling pages.

Direct Shipments to Show Site

Address

To: (Exhibiting Company Name)
(Booth #)

For: **Ag Aviation Expo 2024**

c/o: T3 Expo
c/o: Fort Worth Convention Center
Halls A, B, C
1201 Houston Street
Fort Worth, TX 76133

Please deliver to the loading docks on Commerce Street

Information

Direct shipments are accepted starting on Monday, November 18, 2024 beginning at 8:00 am and throughout published event hours.

Please note when overtime rates apply as stated on Material Handling pages.

PLEASE NOTE: There is no Marshalling Yard at this venue.

T3 Advance Discount Deadline:
Order and payment due by Friday, October 25, 2024

Vehicle Spotting Fee

T3 Expo is responsible for the placement and removal of all motorized units/vehicles entering and exiting the exhibit hall.

All vehicles being used on the exhibit hall floor, either as an actual exhibit or as part of the exhibit space, must be escorted by a T3 Expo spotting crew. There is a round trip fee per vehicle for this service.*

Please Note:

- The battery cables must be disconnected
- The gas cap must either be taped shut or have a lockable gas cap
- The vehicle must contain less than 1/4 tank of gas
- Exhibitor is responsible for checking local Fire Marshal rules and regulations for additional requirements

The Fire Marshal requires that certain safety regulations are adhered to for all vehicles on the exhibit floor. Please see the facility & US Fire Department regulations in this kit; exhibitor is responsible for making sure that all requirements are met.

*Additional fees may apply if vehicle cannot be driven into place and must be assisted or if scheduled spotting time is missed. Oversize vehicles will be charged additional fees.

Requested Date & Time for Vehicle(s) Delivery:

Deliver _____ (Day/Date) _____ (Time)

Pick Up _____ (Day/Date) _____ (Time)

Number of vehicles		Price per vehicle (round trip)		Extended Price
_____	x	\$275.00	=	\$ _____

Company Name: _____
 Contact Name: _____
 Email Address: _____
 Cell Phone: _____
 Booth #: _____

The following information is required; please return completed form to T3 Expo. Email this completed form along with the Payment Information Form to: orders@t3expo.com

Total Spotting Fee Estimate \$ _____

Cartload Service

To alleviate issues associated with exhibitors carrying small exhibit materials during move-in, T3 Expo is pleased to provide a Cartload Service. This service will be available during move-in and move-out.

Cartload Services are designed for use by privately owned vehicles (POVs). A POV is considered to be any vehicle that is primarily designed to transport passengers, not cargo or freight. Examples include cars, pickup trucks, passenger vans, taxis, limos, etc. Bobtails, box trucks or pickup trucks pulling small trailers are not considered POVs and Material Handling rates will apply. No cartload can have a combined weight of more than 300 lbs. Material Handling charges will apply to any loads greater than the limits listed above.

Special Freight Services – Small Passenger Vehicles Only! Maximum Weight 300 lbs

- Each cartload will handle (8) pieces or less, weighing less than 300 lbs. total. Each exhibitor will be provided (1) laborer with (1) cart. Each exhibitor will be allowed a maximum of (2) trips from their vehicle to their booth for move-in and (2) return trips from their booth to their vehicle for move-out.
- T3 Expo personnel will direct all vehicles. The cart is not authorized to enter or go to any parking structure. There must be two (2) people with your vehicle; one (1) person to go with your product to the booth space and one (1) person to remove your vehicle from the unloading area to the parking area once Cartload Service is complete.
- The vehicles must be unload/loaded by full-time exhibitor personnel, by hand.
- Material handling charges and processes will apply to any loads greater than the limits listed above and/or any vehicles that are deemed by T3 Expo not to be a POV.



Hand-carry Information

- This service is for those who have small hand-carry items, all of which must fit on the cart.

To receive this service, watch for the Cartload Service signage

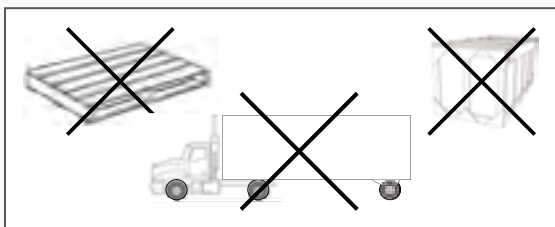

Cartload Service	Anticipated number of trips (2) maximum each way	Price per trip (each way)	Extended Price
Inbound	_____	x \$56.00 = \$	_____
Outbound	_____	x \$56.00 = \$	_____

Cost is each way and a 2-trip maximum. Not for equipment, skidded or crated items. Not for more than (8) pieces, 300 lbs total per trip.

Company Name: _____
 Contact Name: _____
 Email Address: _____
 Cell Phone: _____
 Booth #: _____

The following information is required; please return completed form to T3 Expo. Email this completed form along with the Payment Information Form to: orders@t3expo.com

Total Cart Service Fee Estimate \$ _____



Get the Show on the Road

TForce Freight Trade Show

Your booth is the centerpiece of your company's trade show presence. If it doesn't arrive intact and on-time, your business could miss out on a golden opportunity to gain exposure within the industry.

At TForce Freight, we understand your trade show needs, and we're here to ensure your trade show shipping experience is easier than ever.

Whether your booth is headed for the advanced warehouse or direct to the show site, the TForce Freight Trade Show team can provide you with dependable transit times at the right price — ensuring that your trade show experience goes off without a hitch.



Vast Network Coverage

TForce Freight Trade Show has established a massive network of more than 200 facilities throughout the United States. Which allows us to provide you competitive time-in-transit speeds to and from all major trade show markets.

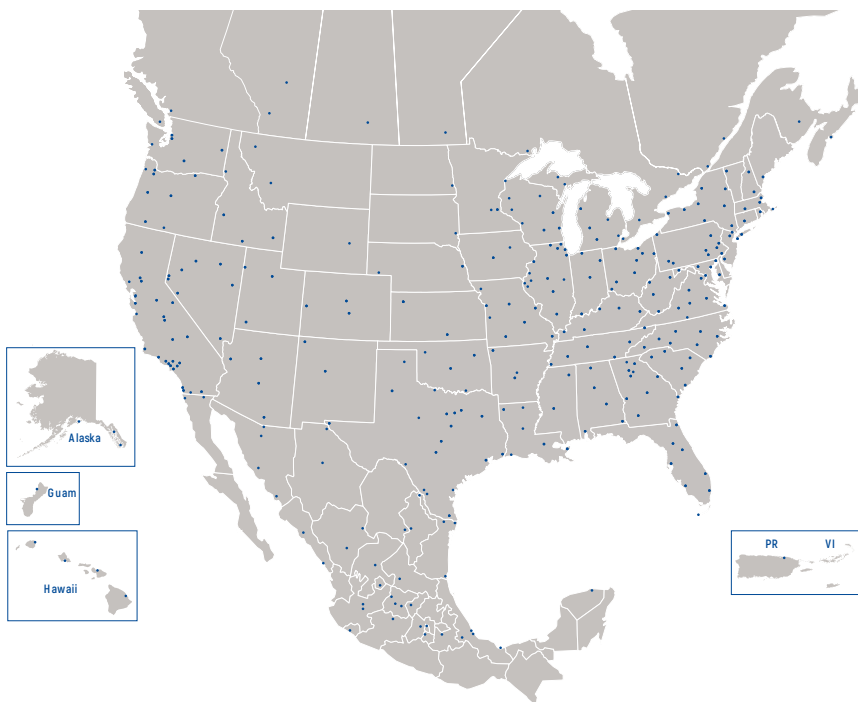



TForce Freight Trade Show Features & Benefits



Guaranteed On-time

We are so confident in our ground freight shipping that we guarantee it's delivered on-time, or your money back.*



Professional Assistance

TForce Freight has trade show specialists available 24/7 to assist you with pre-planning your show. As well as, on-site Regional Managers to assist you with any questions or concerns during the show.



Real-Time Tracking

Experience advanced real-time tracking with TForce Freight technology. You can monitor packages, documents, and high valued goods and assets as they make their way from the loading dock to your exhibit.



Expedited Shipping

When you have a time-sensitive shipment that needs to be there, choose TForce Freight Expedited, and we'll put our seamless, multi-modal transportation network to work for you.



Faster Unloading

TForce Freight has developed strong relationships with several of the largest general service contractors, granting TForce Freight Trade Show with "Official Show Carrier" status at select venues. This allows TForce Freight to use a dedicated delivery door at the event, speeding up the delivery process.



Caravan Service

TForce Freight Trade Show has established a caravan service between select show locations. By joining the caravan you'll streamline your shipments and have your booth delivered to our advanced warehouse days before the show starts.

For more information or to schedule a pickup, please contact
TForce Freight Trade Show at: 800-988-9889 or tforcefreight.com

*Applies for trade show deliveries only. No-fee guarantee applies for shipments rated on current 560/525 tariff only. Shipments rated on customized rates are eligible for a "fee-based" guaranteed service. Certain restrictions apply. See rules tariff for more information.

ADVANCE SHIPMENT

ACCEPTED FROM FRIDAY, OCTOBER 11, 2024 TO FRIDAY, NOVEMBER 8, 2024

To: _____

Exhibitor Name

c/o: T3 Expo

c/o: TForce Freight c/o Crane Cartage LLC

4050 Valley View Ln, Ste 100

Irving, TX 75038

Event: **Ag Aviation Expo 2024**

Booth #: _____

Piece #: _____ of: _____ pieces

ADVANCE SHIPMENT

ACCEPTED FROM FRIDAY, OCTOBER 11, 2024 TO FRIDAY, NOVEMBER 8, 2024

To: _____

Exhibitor Name

c/o: T3 Expo

c/o: TForce Freight c/o Crane Cartage LLC

4050 Valley View Ln, Ste 100

Irving, TX 75038

Event: **Ag Aviation Expo 2024**

Booth #: _____

Piece #: _____ of: _____ pieces

These labels are provided for your convenience; please affix to each piece shipped to ensure proper delivery.

These labels are provided for your convenience; please affix to each piece shipped to ensure proper delivery.

DIRECT SHIPMENT

ACCEPTED BEGINNING MONDAY, NOVEMBER 18, 2024

To: _____

Exhibitor Name

c/o: T3 Expo
c/o: Fort Worth Convention Center
Halls A, B, C
1201 Houston Street
Fort Worth, TX 76133

Deliver to the loading docks on Commerce Street

Event: **Ag Aviation Expo 2024**

Booth #: _____

Piece #: _____ of: _____ pieces

DIRECT SHIPMENT

ACCEPTED BEGINNING MONDAY, NOVEMBER 18, 2024

To: _____

Exhibitor Name

c/o: T3 Expo
c/o: Fort Worth Convention Center
Halls A, B, C
1201 Houston Street
Fort Worth, TX 76133

Deliver to the loading docks on Commerce Street

Event: **Ag Aviation Expo 2024**

Booth #: _____

Piece #: _____ of: _____ pieces

These labels are provided for your convenience; please affix to each piece shipped to ensure proper delivery.

HANGING SIGN ADVANCE SHIPMENT

ACCEPTED FROM FRIDAY, OCTOBER 11, 2024 TO FRIDAY, NOVEMBER 8, 2024

To: _____

Exhibitor Name

c/o: T3 Expo

c/o: TForce Freight c/o Crane Cartage LLC

4050 Valley View Ln, Ste 100

Irving, TX 75038

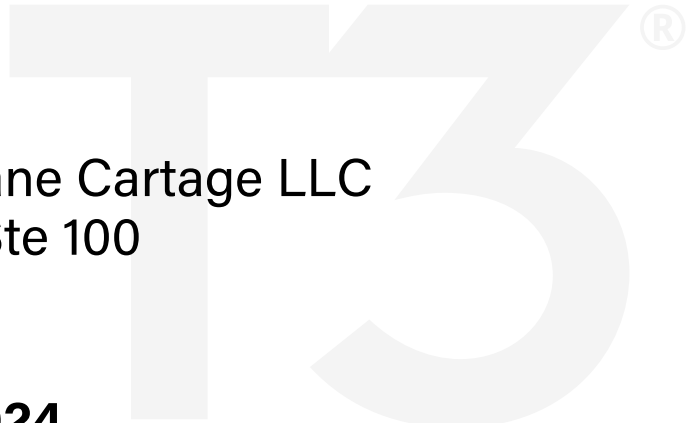

Event: **Ag Aviation Expo 2024**

Booth #: _____

Piece #: _____ of: _____ pieces

HANGING SIGN ADVANCE SHIPMENT

ACCEPTED FROM FRIDAY, OCTOBER 11, 2024 TO FRIDAY, NOVEMBER 8, 2024

To: _____

Exhibitor Name

c/o: T3 Expo

c/o: TForce Freight c/o Crane Cartage LLC

4050 Valley View Ln, Ste 100

Irving, TX 75038

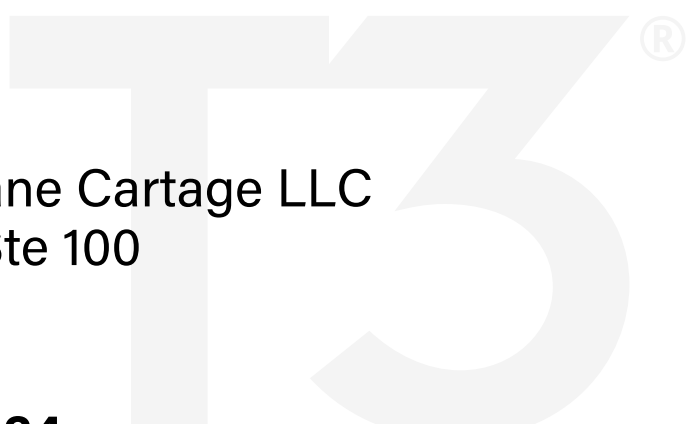

Event: **Ag Aviation Expo 2024**

Booth #: _____

Piece #: _____ of: _____ pieces

T3 SERVICE INFORMATION & FORMS

Exhibitor Order Deadline:Friday, October 11, 2024
Artwork Submission Deadline: Friday, October 18, 2024
Artwork Approval Deadline:..... Friday, October 25, 2024
 An additional 25% rush fee will be added to the total price of the package if graphic files are received after Friday, October 18, 2024.

10' x 10' Presta™ Rental Exhibit Package



The following information is required; please return completed form to T3 Expo.

Review Package

- 9'w x 8'h Digitally Printed Back Wall
- 10' x 10' Standard Carpet
- (1) White, Lockable R4 Counter
- (3) Clip Lights (electricity not included)
- Labor to Install and Dismantle
- First Day Cleaning

Submitting Artwork

Before submitting artwork, please see our Print Production Artwork Requirements. There you will find information on file setup and formats, as well as a link to upload graphics and download templates.

Select Carpet Color (Included in package price; check one)

- | | | | |
|-------|------|--------|------|
| Black | Blue | Green | Grey |
| Navy | Red | Tuxedo | |

Submit This Form

Email this completed form along with the Payment Information Form to: orders@t3expo.com

Company Name: _____
 Contact Name: _____
 Email Address: _____
 Cell Phone: _____
 Booth #: _____

10' x 10' Rental Exhibit Package **\$5,258.00**
 Sales Tax 8.25%..... \$ _____
 Estimated Rental Package Total..... \$ _____
 Pricing does not include electricity, internet connection or AV equipment.

Exhibitor Order Deadline:Friday, October 11, 2024
Artwork Submission Deadline: Friday, October 18, 2024
Artwork Approval Deadline:..... Friday, October 25, 2024
 An additional 25% rush fee will be added to the total price of the package if graphic files are received after Friday, October 18, 2024.

10' x 20' Presta™ Rental Exhibit Package



The following information is required; please return completed form to T3 Expo.

Review Package

- 18'w x 8'h Digitally Printed Back Wall
- 10' x 20' Standard Carpet
- (2) White, Lockable R4 Counters
- (1) Reception Counter with Digital Graphic
- (6) Clip Lights (electricity not included)
- Labor to Install and Dismantle
- First Day Cleaning

Company Name: _____
 Contact Name: _____
 Email Address: _____
 Cell Phone: _____
 Booth #: _____

Submitting Artwork

Before submitting artwork, please see our Print Production Artwork Requirements. There you will find information on file setup and formats, as well as a link to upload graphics and download templates.

Select Carpet Color (Included in package price; check one)

- | | | | |
|-------|------|--------|------|
| Black | Blue | Green | Grey |
| Navy | Red | Tuxedo | |

Submit This Form

Email this completed form along with the Payment Information Form to: orders@t3expo.com

10' x 20' Rental Exhibit Package	\$11,100.00
Sales Tax 8.25%.....	\$ _____
Estimated Rental Package Total.....	\$ _____
Pricing does not include electricity, internet connection or AV equipment.	

Drayage Order Deadline: Friday, October 18, 2024
Discount Price Deadline: Friday, October 18, 2024
Booth package prices will increase by 30% after October 18, 2024.

10' x 10' Booth Package

10' x 10' Basic Booth Package:

All linear booth exhibitors will receive:

- 8' High Back Drape
- 3' High Side Drape
- (1) Identification Sign (44"w x 7"h)
- (1) Wastebasket..... Cost: Included

Upgrade Linear Booth Option 1:

In addition to the Basic Booth Package, T3 Expo will provide:

- (2) Side Chairs
- (1) Wastebasket
- (1) 6'w x 2'd x 30"h Skirted Table – Black Cost: \$132.00

Upgrade Linear Booth Option 2:

In addition to the Basic Booth Package, T3 Expo will provide:

- (2) Side Chairs
- (1) Wastebasket
- (1) 8' Skirted Table – Black Cost: \$143.00

Upgrade Linear Booth Option 3:

In addition to the Basic Booth Package, T3 Expo will provide:

- (1) 40" Round Table
- (1) Wastebasket
- (2) Bar Stools..... Cost: \$200.00

Additional Discounted Items for Exhibit Booths:

	Quantity		Extended Price
(1) 6'w x 2'd x 30"h Draped Table – Black	_____	\$112.00/ea	\$ _____
(1) 8'w x 2'd x 30"h Draped Table – Black	_____	\$126.00/ea	\$ _____
(1) Individual Basic Side Chair.....	_____	\$97.00/ea	\$ _____
(1) 10' x 10' Standard Carpet (Please check one color below)	_____	\$219.00/ea	\$ _____

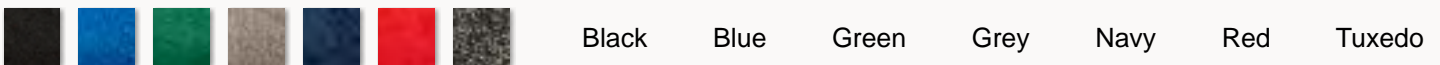

A discounted Drayage Package can be ordered separately.

Drayage Package for 10' x 10' Booths:

In addition to the Basic Booth Package, T3 Expo offers unlimited drayage.

	Quantity		Extended Price
10' x 10' Booth with Unlimited Drayage is \$898.00	_____	\$898.00/ea	\$ _____

NOTE: Furnishings not included. All other booth sizes are not eligible.

Aircraft Only Booths:

All-inclusive flat drayage rate for exhibitors that bring in full size aircraft into their booths in the Expo Hall

\$5.72 per sq. ft. of exhibit space \$ _____

Company Name: _____
 Contact Name: _____
 Email Address: _____
 Cell Phone: _____
 Booth #: _____

10' x 10' Booth Package	\$ _____
Sales Tax 8.25%	\$ _____
Estimated Booth Package Total	\$ _____
Pricing does not include electricity, internet connection or AV equipment.	

Drayage Order Deadline: Friday, October 18, 2024
Discount Price Deadline: Friday, October 18, 2024
 Booth package prices will increase by 30% after October 18, 2024.

10' x 20' Booth Package

10' x 20' Basic Booth Package:

All linear booth exhibitors will receive:

- 8' High Back Drape
- 3' High Side Drape
- (1) Identification Sign (44"w x 7"h)
- (1) Wastebasket..... Cost: Included

Upgrade Linear Booth Option 1:

In addition to the basic booth package, T3 Expo will provide:

- (2) Side Chairs
- (1) Wastebasket
- (1) 6'w x 2'd x 30"h Skirted Table – BlackCost: \$132.00

Upgrade Linear Booth Option 2:

In addition to the basic booth package, T3 Expo will provide:

- (2) Side Chairs
- (1) Wastebasket
- (1) 8'w x 2'd x 30"h Skirted Table – BlackCost: \$143.00

Upgrade Linear Booth Option 3:

In addition to the basic booth package, T3 Expo will provide:

- (1) 40" Round Table
- (1) Wastebasket
- (2) Bar StoolsCost: \$200.00

Additional Discounted Items for Exhibit Booths:

	Quantity		Extended Price
(1) 6'w x 2'd x 30"h Draped Table – Black	_____	\$112.00/ea	\$ _____
(1) 8'w x 2'd x 30"h Draped Table – Black	_____	\$126.00/ea	\$ _____
(1) Individual Basic Side Chair.....	_____	\$97.00/ea	\$ _____
(1) 10' x 20' Standard Carpet (Please check one color below)	_____	\$437.00/ea	\$ _____



A discounted Drayage Package can be ordered separately.

Drayage Package for 10' x 20' Booths:

In addition to the Basic Booth Package, T3 Expo offers unlimited drayage.

	Quantity		Extended Price
10' x 20' Booth with Unlimited Drayage is \$1,796.00	_____	\$1,796.00/ea	\$ _____

NOTE: Furnishings not included. All other booth sizes are not eligible.

Aircraft Only Booths:

All-inclusive flat drayage rate for exhibitors that bring in full size aircraft into their booths in the Expo Hall

\$5.72 per sq. ft. of exhibit space \$ _____

Company Name: _____
 Contact Name: _____
 Email Address: _____
 Cell Phone: _____
 Booth #: _____

10' x 20' Booth Package	\$ _____
Sales Tax 8.25%	\$ _____
Estimated Booth Package Total	\$ _____
Pricing does not include electricity, internet connection or AV equipment.	

Artwork Submission Deadline:
All artwork due by Friday, October 18, 2024

Print Production Artwork Requirements

PLEASE NOTE:

All artwork must be submitted in **CMYK** (not RGB/HEX).

General File Set Up

Please provide artwork in native forms whenever possible:

- Adobe Illustrator and Adobe InDesign files are preferred

When creating multiple-panel signs/structure graphics (booth back walls, etc.):

- Use Adobe Illustrator for layout
- Create artwork using one artboard for entire graphic. Don't use separate artboards for artwork spanning more than one panel.
- Include **2" bleeds** on all sides
- Convert fonts to outlines
- Embed all linked images

When creating single-panel graphics/smaller signs (meter boards, placards, etc.):

- Use Adobe Illustrator or InDesign for layout
- Include **1" bleeds** on all sides
- Convert fonts to outlines
- Embed or package all linked images

Images

Rasterized pixel-based images such as PSD, TIF or JPGs should be high resolution (150-300 dpi) at full size, 1:1 ratio. This includes images linked or embedded in InDesign or Illustrator files.

Based on viewing distance, below are some basic guidelines for resolution when working with formats such as PSD, TIF and JPG files.

48" x 96" Graphics and larger

Recommended resolution for graphic at full size dimensions:

- Viewing distance of 1-4 feet 200 dpi at full size
- Viewing distance of 5-9 feet 150 dpi at full size

Minimum resolution for graphic at full size dimensions:

- Viewing distance of 1-4 feet 150 dpi at full size
- Viewing distance of 5-9 feet 100 dpi at full size

Graphics smaller than 48" x 96"

- Viewing distance of 1-4 feet 100 dpi at full size

Preferred File Formats

- Adobe Illustrator (AI or EPS): Outline fonts and embed all links
- Adobe InDesign: Package all fonts and links
- Adobe Photoshop (PSD, TIF or JPG): For image files

Checklist

SET DOCUMENT MODE TO CMYK

USE APPROPRIATE DIMENSIONS AND SCALE

SET APPROPRIATE BLEEDS ON ALL SIDES

CHECK IMAGE RESOLUTION

CONVERT FONTS TO OUTLINES

EMBED IMAGES / SAVE & PACKAGE YOUR FILE

INCLUDE PDF PROOF

Artwork Submission and Template Download

[CLICK HERE](#) to upload your graphic files once they're complete or to download graphic templates.

Questions?

Questions regarding artwork may be emailed to:

Exhibitor Graphics
graphics@t3expo.com

Please include, in all inquiries:

- Event name
- Company name
- Booth number
- Contact information

Carpet Options

Upgraded Carpet – 30 oz. Premium 100% Nylon Carpet

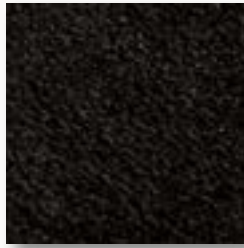

Black

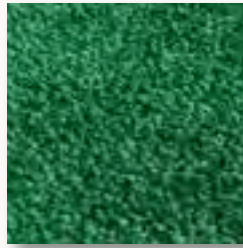

Green



Grey



Navy



Red

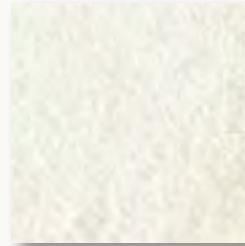

White

Standard Carpet – 16 oz. Nylon Carpet



Black

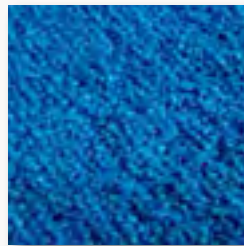

Blue

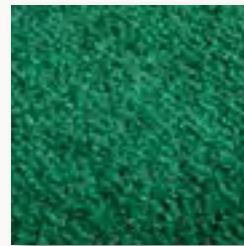

Green

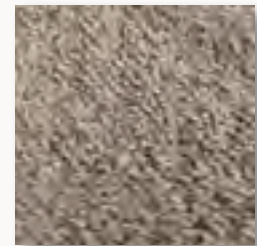

Grey

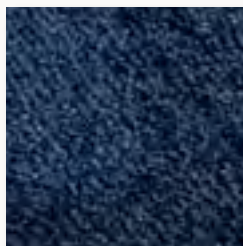

Navy

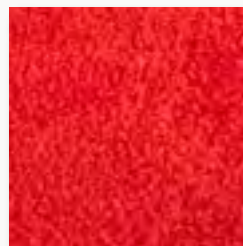

Red



Tuxedo

PLEASE NOTE: Colors and style may vary upon availability.

T3 Advance Discount Deadline:
Order and payment due by Friday, October 25, 2024

Carpet & Padding Order Form

Upgraded Carpet – 30 oz. Premium 100% Nylon Carpet

Please enter size and select carpet color

The booth space is not carpeted and floor covering is not required but may be ordered.

Booth Dimensions	Total Area	Discount Price	Standard Price	Extended Price
Size _____ x _____ = _____ sq. ft		x \$8.98	or \$12.83	= \$ _____

Please select UPGRADED carpet color: (check one)	Black Navy	Green Red	Grey White
--	---------------	--------------	---------------

Standard Carpet – 16 oz. nylon carpet – **Please enter size and select carpet color**

Discount Price	Standard Price	Extended Price	Discount Price	Standard Price	Extended Price
10' x 10' \$386.00	or \$551.43	\$ _____	20' x 20' \$1,544.00	or \$2,205.71	\$ _____
10' x 20' \$772.00	or \$1,102.86	\$ _____	20' x 30' \$2,316.00	or \$3,308.57	\$ _____
10' x 30' \$1,158.00	or \$1,654.29	\$ _____	20' x 40' \$3,088.00	or \$4,411.43	\$ _____
10' x 40' \$1,544.00	or \$2,205.71	\$ _____	30' x 30' \$3,474.00	or \$4,962.86	\$ _____

20' carpet comes as two matching 10' pieces.

Custom Size – Custom size is required for larger, island or peninsula booths, or if size needed is not shown above.

Please enter size and select carpet color

Booth Dimensions	Total Area	Discount Price	Standard Price	Extended Price
Size _____ x _____ = _____ sq. ft		x \$3.86	or \$5.51	= \$ _____

Please select STANDARD or CUSTOM carpet color: (check one)	Black Navy	Blue Red	Green Tuxedo	Grey
--	---------------	-------------	-----------------	------

Carpet Padding

Booth Dimensions	Total Area	Discount Price	Standard Price	Extended Price
½" Foam Padding* _____ x _____ = _____ sq. ft		x \$1.73	or \$2.47	= \$ _____
Visqueen _____ x _____ = _____ sq. ft		x \$1.40	or \$2.00	= \$ _____

Subtotal: \$ _____

Company Name: _____
Contact Name: _____
Email Address: _____
Cell Phone: _____
Booth #: _____

Sales Tax 8.25% \$ _____
Estimated Total Carpet \$ _____

Furniture – Standard Chairs



A. Bar Stool, Black



B. Side Chair, Black

PLEASE NOTE: Colors and style may vary upon availability.

Accessories / Pipe & Drape

- A. Bag Stand – Chrome
- B. Literature Holder – Acrylic 3 Tier
- C. Poster Display Board
- D. R4 Counter – 4' wide, Rounded Corners
R4 Counter with Custom Graphics (*not shown*)
- E. Sign Easel
- F. Literature Stand
- G. Sign Stand – 22" w x 28" h
- H. Display Showcase, 6'
- I. Stanchion – 3' High Tension
- J. Wastebasket

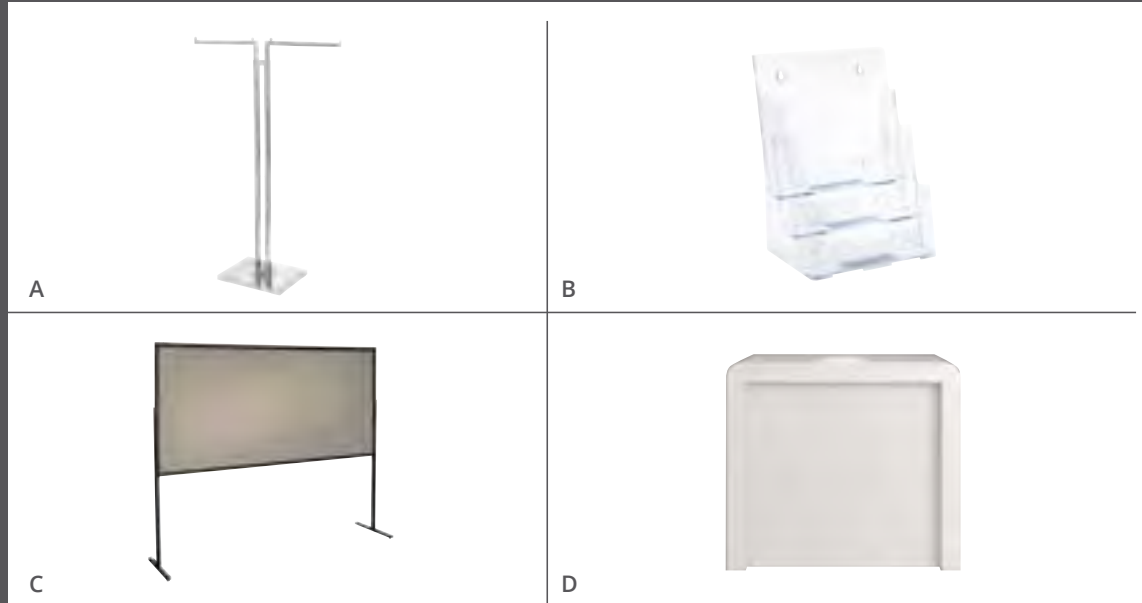

Pipe & Drape

- A. 8' High Drape
- B. 3' High Drape

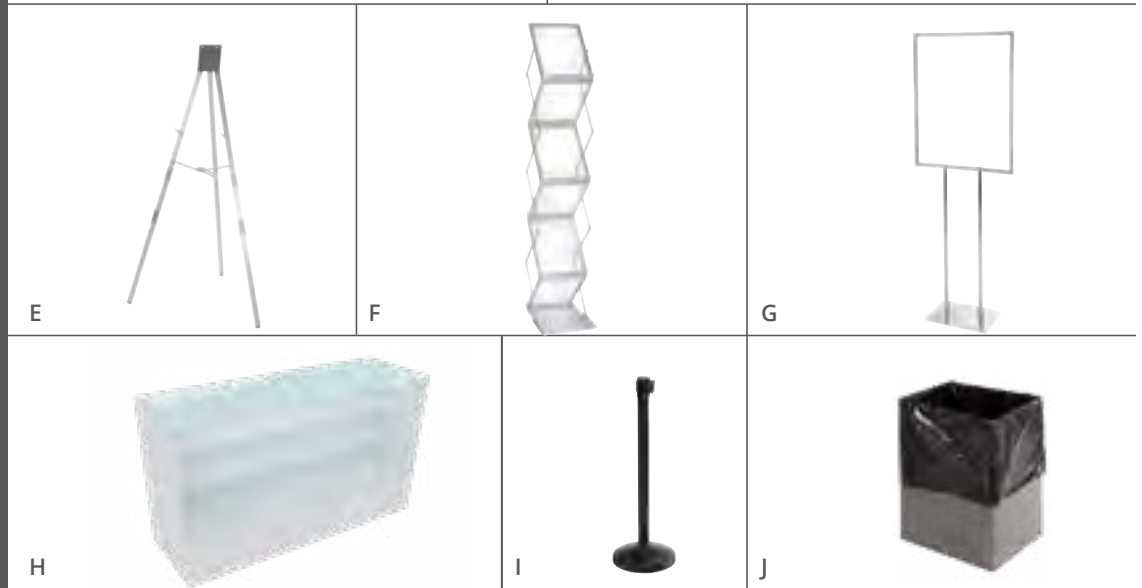

PLEASE NOTE:
Colors and style may vary upon availability.

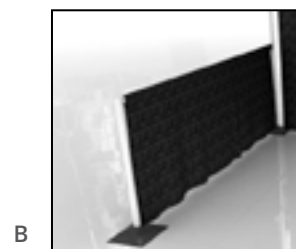
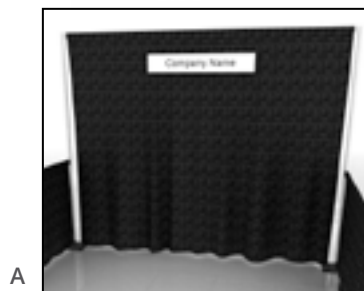

T3 Advance Discount Deadline:
Order and payment due by Friday, October 25, 2024

Furniture / Accessories / Pipe & Drape Order Form

	Quantity		Discount Price	or	Standard Price	=	Extended Price
Furniture							
A. Bar Stool – Black (FRN-BRSTL-01a)	_____	x	\$284.00	or	\$405.71	= \$	_____
B. Side Chair – Black (FRN-SIDEXHR-01a)	_____	x	\$192.00	or	\$274.29	= \$	_____

	Quantity		Discount Price	or	Standard Price	=	Extended Price
Accessories							
A. Bag Stand (ACC-001a)	_____	x	\$304.00	or	\$434.29	= \$	_____
B. Literature Holder – Acrylic 3 Tier (ACC-002a)	_____	x	\$108.00	or	\$154.29	= \$	_____
C. Poster Display Board (FRN-PSTBRD-01a)	_____	x	\$314.00	or	\$448.57	= \$	_____
D. R4 Counter – 4' wide (CNT-R4FT-01a)	_____	x	\$1,009.00	or	\$1,441.43	= \$	_____
R4 Counter, Branded – 4' wide (CNT-R4FT-01b)	_____	x	\$1,152.00	or	\$1,645.71	= \$	_____
E. Sign Easel (ACC-004a)	_____	x	\$127.00	or	\$181.43	= \$	_____
F. Literature Stand (ACC-005a)	_____	x	\$240.00	or	\$342.86	= \$	_____
G. Sign Stand – 22" w x 28" h (ACC-007a)	_____	x	\$194.00	or	\$277.14	= \$	_____
H. Display Showcase, 6'	_____	x	\$588.00	or	\$840.00	= \$	_____
I. Stanchion – 3' High Tension (ACC-008a)	_____	x	\$134.00	or	\$191.43	= \$	_____
J. Wastebasket (ACC-010a)	_____	x	\$38.00	or	\$54.29	= \$	_____

	Quantity		Discount Price	or	Standard Price	=	Extended Price
Pipe & Drape							
A. Banjo Drape 8'H, Black (BDRP-8)	_____	x	\$24.00	or	\$34.29	= \$	_____
B. Banjo Drape 3'H, Black (BDRP-3)	_____	x	\$16.00	or	\$22.86	= \$	_____

Please Select Drape Color: (check one)

Black
 Blue
 Burgundy
 Gold
 Green
 Grey
 Plum
 Red
 White

Company Name: _____
 Contact Name: _____
 Email Address: _____
 Cell Phone #: _____
 Booth #: _____

Sales Tax 8.25% \$ _____
Est. Total Furn/Access/Pipe&Drape.. \$ _____

Display Tables & Counters

Skirted Tables

- 4'w x 2'd x 30"h (shown)
- 6'w x 2'd x 30"h
- 8'w x 2'd x 30"h
- 4'w x 2'd x 40"h
- 6'w x 2'd x 40"h
- 8'w x 2'd x 40"h

- Skirted tables include white vinyl top and pleated skirt on three sides.
- Fourth side skirting is available at an additional cost.
- 4' tables do not require fourth side skirting.

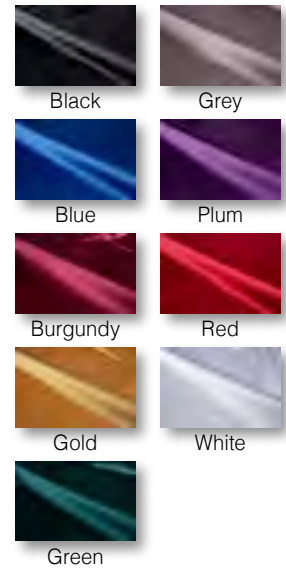

Unskirted Tables

- 4'w x 2'd x 30"h
- 6'w x 2'd x 30"h
- 8'w x 2'd x 30"h
- 4'w x 2'd x 40"h
- 6'w x 2'd x 40"h
- 8'w x 2'd x 40"h

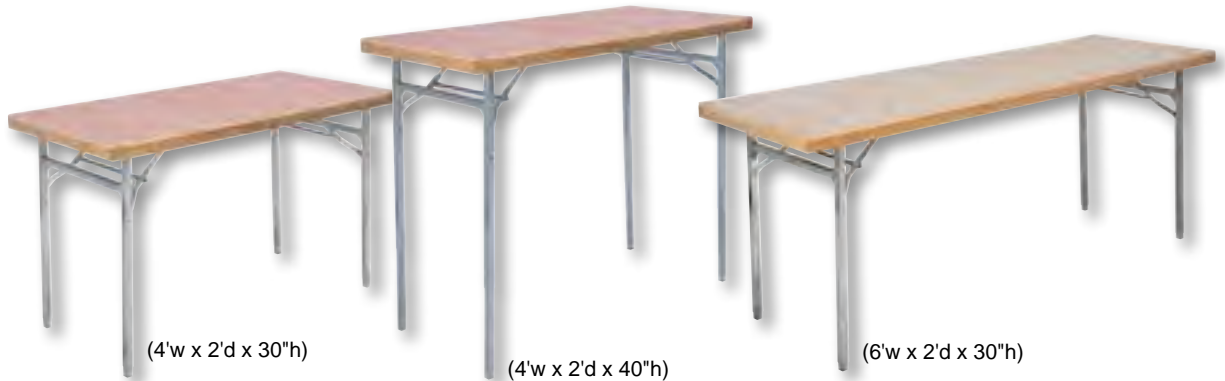

Round Tables

- 30" diameter x 30"h – Black
- 30" diameter x 40"h – Black



Skirting not available on round tables.

PLEASE NOTE:

Colors and style may vary upon availability for items on this page.

T3 Advance Discount Deadline:
Order and payment due by Friday, October 25, 2024

Display Tables & Counters Order Form

	Quantity		Discount Price		Standard Price		Extended Price
30" High Skirted (6' & 8' skirted on 3 sides only)							
4'w x 2'd	_____	x	\$251.00	or	\$358.57	= \$	_____
6'w x 2'd	_____	x	\$292.00	or	\$417.14	= \$	_____
8'w x 2'd	_____	x	\$341.00	or	\$487.14	= \$	_____
4th Side Skirting (for 6' and 8' tables only)	_____	x	\$79.00	or	\$112.86	= \$	_____
40" High Skirted (6' & 8' skirted on 3 sides only)							
4'w x 2'd	_____	x	\$292.00	or	\$417.14	= \$	_____
6'w x 2'd	_____	x	\$341.00	or	\$487.14	= \$	_____
8'w x 2'd	_____	x	\$390.00	or	\$557.14	= \$	_____
4th Side Skirting (for 6' and 8' tables only)	_____	x	\$92.00	or	\$131.43	= \$	_____

Please Select Skirting Color: (check one)

Black
 Blue
 Burgundy
 Gold
 Green
 Grey
 Plum
 Red
 White

	Quantity		Discount Price		Standard Price		Extended Price
30" High Unskirted							
4'w x 2'd	_____	x	\$97.00	or	\$138.57	= \$	_____
6'w x 2'd	_____	x	\$130.00	or	\$185.71	= \$	_____
8'w x 2'd	_____	x	\$158.00	or	\$225.71	= \$	_____
40" High Unskirted							
4'w x 2'd	_____	x	\$130.00	or	\$185.71	= \$	_____
6'w x 2'd	_____	x	\$158.00	or	\$225.71	= \$	_____
8'w x 2'd	_____	x	\$188.00	or	\$268.57	= \$	_____
Round Tables							
30"d x 30"h, black	_____	x	\$172.00	or	\$245.71	= \$	_____
30"d x 40"h, black	_____	x	\$192.00	or	\$274.29	= \$	_____

Company Name: _____
 Contact Name: _____
 Email Address: _____
 Cell Phone #: _____
 Booth #: _____

Sales Tax 8.25% \$ _____
Est. Total Display Tables & Counters \$ _____

Display Labor & Forklift Order Form

Important Information

- Straight Time: 8:00 am to 4:30 pm, Monday-Friday.
- Overtime: Before 8:00 am and after 4:30 pm, Monday-Friday, and all hours on Saturday.
- Double Time: Sunday and observed union holidays.
- Show Site Labor Orders: Add 30% to hourly rates.
- T3 Expo bills 30 minutes minimum per laborer. Additional time is billed in 30 minute increments per laborer.
- Exhibitors ordering forklift will be assigned a forklift and an operator.
- Determination of crew size is at the discretion of T3 Expo.
- Starting time is to be confirmed with T3 Expo. Only labor ordered for 8:00 am start time is guaranteed. All other start times will begin as soon as labor is available.
- Exhibitors MUST check in at the T3 Expo Service Desk when ready for labor, and check out at the T3 Expo Service Desk upon completion of work.
- Exhibitors ordering forklift to assemble displays or for uncrating, unskidding, positioning and reskidding equipment or machinery will need to estimate their needs on this form.

	Straight Time	Overtime	Double Time
Display Labor			
Labor	\$170.00	\$242.00	\$335.00
T3 Supervised Labor	\$221.00	\$315.00	\$436.00
Forklift and Operator.....	\$394.00	\$436.00	\$563.00

	Requested Date/Time	# of Laborers	# Hours	Hourly Rate	Total Cost
Installation	_____	_____ x _____	_____ x _____	_____ = \$ _____	
	_____	_____ x _____	_____ x _____	_____ = \$ _____	
Dismantle	_____	_____ x _____	_____ x _____	_____ = \$ _____	
	_____	_____ x _____	_____ x _____	_____ = \$ _____	

For Forklift Orders

Type of Work Being Performed

- Unskid/reskid equipment
- Place equipment
- Build booth structure
- Other: _____

Size of forklift required:

- 5,000 lb lift
- 10,000 lb lift
- 15,000 lb lift

Heaviest piece weight _____ Dimensions _____ x _____ x _____
length width height

For Display Labor – Supervision of all labor is required (check one)

Exhibitor Supervision On site/after hours contact cell phone: _____
On site/after hours contact name: _____

T3 Expo Supervision On site/after hours contact cell phone: _____
On site/after hours contact name: _____

Our fee for T3 Supervision is 30% of the exhibitor's total labor bill. In order to perform the labor without exhibitor's representative present, T3 Expo must receive detailed set-up instructions (blueprints/floor plans, etc.) with this labor order form. Exhibitor must also include outbound shipping instructions with this labor order form.

Company Name: _____
 Contact Name: _____
 Email Address: _____
 Cell Phone: _____
 Booth #: _____

Set-Up Instructions Attached

Outbound Shipping Information Attached

Estimated Total Labor \$ _____

T3 Expo will hang signs 150 lbs or less. Fort Worth Convention Center must rig anything over 150 lbs. See page 103 for more details on rigging.

Hanging Sign Order Form

Important Information

- Straight Time: 8:00 am to 4:30 pm, Monday-Friday.
- Overtime: Before 8:00 am and after 4:30 pm, Monday-Friday, and all hours on Saturday.
- Double Time: Sunday and observed union holidays.
- Show Site Labor Orders: Add 30% to hourly rates.
- T3 Expo bills in one hour increments per crew for Sign Hanging.
- Hanging Signs should be sent in a separate container to the Advance Shipping Warehouse using the enclosed "Hanging Sign" labels and adhering to the dates on the labels.
- All Hanging Signs are subject to approval and must conform to Show Management and facility regulations.
- Signs requiring electricity must be in accordance with the National Electrical Code.
- T3 Expo reserves the right to refuse to hang any sign which we deem to be unsafe.
- If any hang point supports over 250 lbs., notify T3 immediately for special authorization.

	Straight Time	Overtime	Double Time
Sign Assembly Labor.....	\$170.00	\$242.00	\$335.00
T3 Supervised Sign Assembly Labor.....	\$221.00	\$315.00	\$436.00

Does the sign require assembly? Yes No
(assembly labor performed at rates above)

Requested Date & Time**	# of Men	# of Hours	Hourly Rate	Total Cost
Installation _____	_____	x _____	x _____	= \$ _____
Dismantle _____	_____	x _____	x _____	= \$ _____

	Straight Time	Overtime	Double Time
Sign Hanging Lift/Crew	\$868.00	\$1,004.00	\$1,140.00

Requested Date & Time**	# of Lift(s) Crew(s)	# of Hours	Hourly Rate	Total Cost
Installation _____	_____	x _____	x _____	= \$ _____
Dismantle _____	_____	x _____	x _____	= \$ _____

Note: Final billing will include time, materials, assembly, installation and dismantle.
**We will do our best to accommodate the requested date and time.
Crew size is at the discretion of T3 Expo.

Supervision of all labor is required (check one)

Exhibitor Supervision On site/after hours contact cell phone: (____) _____

On site/after hours contact name: _____

T3 Expo Supervision On site/after hours contact cell phone: (____) _____

On site/after hours contact name: _____

In order to perform Labor without exhibitor's representative present, T3 Expo must receive detailed set-up instructions (blueprints/floor plans, etc.) with this form. This must also include outbound shipping instructions.

Set-Up Instructions Attached

Outbound Shipping Information Attached (for T3 Expo Supervised Dismantle only)

Estimated Total Hanging Sign..... \$ _____

Company Name: _____
 Contact Name: _____
 Email Address: _____
 Cell Phone: _____
 Booth #: _____

Hanging Sign Description & Position

Description of Sign

Material

Cloth/Vinyl Wood System Metal Other _____
 Single Sided Double Sided Pockets Grommets # of Hang Points _____

Shape

Square Circle Triangle Pinwheel Other _____

Dimensions

Height _____ Width _____ Length _____ Approx Weight _____ lbs.

Assembly Required?

Yes No

Electricity Required?

Yes No

Chain Motors Required? (call/email T3 Expo for rates)

Yes No Qty _____

Is exhibitor supervision required for T3 Expo to assemble and hang the sign?

Yes No

Position of Sign

Distance from the floor to the top of the sign _____ or _____ to maximum height allowed

Location

Center of Booth

See Diagram Below

Each square = _____

Adjacent Booth or Aisle # = _____

Use this grid to indicate the position of your hanging sign.

- Please indicate the scale of the grid (i.e. 1 square=1 foot) or indicate the dimensions of your booth.
- Mark the adjacent booth numbers or aisle numbers in the space around the grid.

Adjacent Booth or Aisle # = _____

Company Name: _____
Contact Name: _____
Email Address: _____
Cell Phone: _____
Booth #: _____

Accessible Storage & Cleaning Order Form

Important Information

Exhibitor must sign up for accessible storage at the on-site T3 Service Desk.

Accessible storage is for storing items such as giveaways or literature that need to be replenished.

Half hour minimum labor charge to bring items to storage and half hour minimum charge for each time retrieved. Actual hours will be included in final billing.

NOTE: If you are already paying for Advance or Direct Material Handling to T3 Expo, there is no additional charge for Empty Storage. If you are hand-carrying your exhibit and require storage, Empty Storage fees will apply.

Empty Storage fees cover the duration of the event.

Accessible Storage

Accessible Storage is \$3.46 per square foot per day.

*One half hour of labor will be charged to bring items to storage and one half hour for each time items are retrieved from or brought into storage.

Access Storage	Area	# Days	Extended Price
\$3.46 per sq. ft x	_____ sq. ft. x	_____	= \$ _____

	Straight Time	Overtime	Double Time
Access Storage Labor	\$170.00	\$242.00	\$335.00

Empty Storage	Quantity	Standard Price	Extended Price
Cardboard Box	_____ x	\$40.00 each	= \$ _____
Fiber Case	_____ x	\$50.00 each	= \$ _____

Cleaning	Area	Price	# Days	Extended Price
Porter Service	_____ x _____ x	\$1.01 per sq. ft.	x _____	= \$ _____
Vacuuming	_____ x _____ x	\$0.89 per sq. ft.	x _____	= \$ _____

	Quantity	Standard Price
Shrink Wrap	_____	\$115.00

Company Name: _____
 Contact Name: _____
 Email Address: _____
 Cell Phone: _____
 Booth #: _____

Est. Total Storage Services \$ _____



SPECIAL EVENT

Click here to view the
2024 AFR FURNITURE RENTAL CATALOG

2024 FURNITURE PRODUCT LIST WITH PRICING

T3 CUSTOM
FURNITURE
ORDER FORMS

QTY	CODE	ITEM	DETAILS	DIMENSIONS	DISCOUNT PRICE	STANDARD PRICE	TOTAL
ACCESSORIES							
	HDG4WH	Boxwood Hedge, 4'	Green, White	46" L 9"D 47"H	\$1,060.00	\$1,514.29	
	HDG8WH	Boxwood Hedge, 8'	Green, White	36.5"L 12"D 96"H	\$1,533.00	\$2,190.00	
	BURGBR	Buffalo Rug	Brown	60" L 90"D	\$283.00	\$404.29	
	CHRGBR	Cheyenne Rug	Gray, Brown	120" L 96"D	\$378.00	\$540.00	
	CORPLG	Corduroy Pillow	Green	18" L 2"W 18"H	\$63.00	\$90.00	
	CORPLB	Corduroy Pillow	Navy	18" L 2"W 18"H	\$63.00	\$90.00	
	CORPLR	Corduroy Pillow	Rust	18" L 2"W 18"H	\$63.00	\$90.00	
	FLFLBK	Flagstaff Floor Lamp	Matte Black, White	19.75" RND 63"H	\$425.00	\$607.14	
	HUPLGN	Huntington Pillow	Green, Beige	18" L 2"W 18"H	\$63.00	\$90.00	
	KNPLGD	Knoll Velvet Pillow	Golden Wheat, Taupe	18" L 2"W 18"H	\$63.00	\$90.00	
	LGTRE9	Lagos Tree, Large	Terracotta, Green	53" RND 93"H	\$1,470.00	\$2,100.00	
	LGTRE6	Lagos Tree, Medium	Terracotta, Green	53" RND 70"H	\$935.00	\$1,335.71	
	LARGRS	Lancaster Rug	Rose, Lavender	60" L 90"D	\$378.00	\$540.00	
	MARRGG	Marbella Rug	Olive, Beige	60" L 90"D	\$378.00	\$540.00	
	MDPLCL	Medley Pillow	Coral	18" L 2"W 18"H	\$38.00	\$54.29	
	MDPLGN	Medley Pillow	Mint	18" L 2"W 18"H	\$38.00	\$54.29	
	MDPLBL	Medley Pillow	Sea	18" L 2"W 18"H	\$38.00	\$54.29	
	MORGBL	Morro Rug	Blue	120" L 96"D	\$378.00	\$540.00	
	PIRGBL	Pismo Rug	Indigo, Sand	60" L 90"D	\$378.00	\$540.00	
	POPBE	Polka Pillow	Beige, Camel	18" L 2"W 18"H	\$38.00	\$54.29	
	PCBGAC	Posh Corner Bar w/ Grass	LED Lighted w/ AC Plug	30" L 30"D 76"H	\$1,175.00	\$1,678.57	
	PCBGDC	Posh Corner Bar w/ Grass	LED Lighted w/ DC	30" L 30"D 76"H	\$1,175.00	\$1,678.57	
	PCBGUL	Posh Corner Bar w/ Grass	Unlit	30" L 30"D 76"H	\$935.00	\$1,335.71	
	PRPLBL	Province Pillow	Navy, Silver	18" L 2"W 18"H	\$63.00	\$90.00	
	TRITLL	Triad Table Lamp	Brass, White	14" RND 21.75"H	\$425.00	\$607.14	
	HDG4FT	Boxwood Hedge, 4'	Green, Black	46" L 9"D 47"H	\$610.00	\$871.43	
	HDG7FT	Boxwood Hedge, 7'	Green, Black	36.5" L 12" D 84" H	\$1,005.00	\$1,435.71	
	LA15	Mason Floor Lamp	Brushed Silver	18" RND 55"H	\$280.00	\$400.00	
	LA14	Mason Table Lamp	Brushed Silver	16" RND 26"H	\$185.00	\$264.29	
	AELPIL	Albuquerque Pillow	Linon	18" L 18"H	\$25.00	\$35.71	
	AEOPIL	Albuquerque Pillow	Ochre	18" L 18"H	\$25.00	\$35.71	
	AZIPIL	Azibo Pillow	Charcoal, Cream	18" L 18"H	\$63.00	\$90.00	
	BBTREE	Bamboo Tree, 9' (new base)	Green	18" L 18" D 108" H	\$378.00	\$540.00	
	BEEPIL	Bees Pillow	Black/Silver	17" L 17"H	\$25.00	\$35.71	
	CHAPIL	Champagne Velvet Pillow	Champagne	18" L 18"H	\$25.00	\$35.71	
	CIRRUG	Circles Rug	Blue/Gray	96" L 120"D	\$295.00	\$421.43	
	CORPIL	Corduroy Pillow	Beige	18" L 18"H	\$63.00	\$90.00	
	DELREA	Del Mar Tonal Rug	Earth	90" L 60"D	\$295.00	\$421.43	
	DELGR	Del Mar Tonal Rug	Moss Green	90" L 60"D	\$295.00	\$421.43	
	DELFL	Delano Floor Lamp	Black Wire	18" L 18" D 65" H	\$350.00	\$500.00	
	DELTL	Delano Table Lamp	Black Wire w/ Gold Base	15.75" L 15.75" D 27.5" H	\$188.00	\$268.57	
	DIAPIL	Dia Pillow	Silver/Orange/Black	17" L 17"H	\$25.00	\$35.71	
	DSTPIL	Dusty Coral Pillow	Coral	20" L 20"H	\$38.00	\$54.29	
	FLPPIL	Flamingo Pillow	Pink, White	18" L 18"H	\$30.00	\$42.86	
	FLOPIL	Florida Pillow	Red/Blue/Pink	17" L 17"H	\$25.00	\$35.71	
	FLUPIL	Fluff Pillow	White, Charcoal	18" L 18"H	\$25.00	\$35.71	
	FDBPIL	Frayed Lumbar Pillow	Black, Ivory	20" L 12"H	\$25.00	\$35.71	
	FDSPIL	Frayed Lumbar Pillow	Spice Orange, Ivory	20" L 12"H	\$25.00	\$35.71	
	FDTPIL	Frayed Lumbar Pillow	Teal, Ivory	20" L 12"H	\$25.00	\$35.71	
	GRASS	Grass Centerpiece	Green, Black	27.5" L 4" D 14" H	\$203.00	\$290.00	
	HNSAN	Hand Sanitizer Station	White	11.5" L 18" D 51" H	\$360.00	\$514.29	
	HVPLM8	Havana Palm Divider, 8'	White, Green	44" L 24" D 96"H	\$1,388.00	\$1,982.86	
	HVPLM6	Havana Palm, 6'	White, Green	18" L 18" D 72"H	\$405.00	\$578.57	
	IMPSCR	Impact Shag Rug	Cream	60" L 91"D	\$295.00	\$421.43	
	IMPSGN	Impact Shag Rug	Green	60" L 91"D	\$295.00	\$421.43	
	IMPSMN	Impact Shag Rug	Midnight	60" L 91"D	\$295.00	\$421.43	
	IRVFLL	Irvine Floor Lamp	Brass, Black	9.75" D 61"H	\$268.00	\$382.86	
	IRVTLL	Irvine Table Lamp	Brass, Black	7.75" D 21"H	\$188.00	\$268.57	
	JASPIL	Jasna Pillow	Black, Cream	18" L 18"H	\$63.00	\$90.00	
	KABRUG	Karma Rug	Beige, Gray	120" L 96"D	\$378.00	\$540.00	
	KAGRUG	Karma Rug	Gray, Cream	120" L 96"D	\$378.00	\$540.00	
	KENTLL	Kendra Table Lamp	Wood-Look	9.5" RND 19"H	\$188.00	\$268.57	
	KENPIL	Kenya Pillow	Black, Beige	18" L 18"H	\$63.00	\$90.00	
	LSBRUG	Lapis Rug	Blue, Cream Stripe	66" L 82"D	\$283.00	\$404.29	
	DRPLAC	LED Accent Light, w/ AC Plug	Black	5.4" L 5.7" D 7.2" H	\$285.00	\$407.14	
	DRPLDC	LED Accent Light, w/ DC Battery	Black	5.4" L 5.7" D 7.2" H	\$285.00	\$407.14	
	LRBPIL	Linear Pillow	Black with White Lines	18" L 18"H	\$25.00	\$35.71	
	LRWPIL	Linear Pillow	White with Black Lines	18" L 18"H	\$25.00	\$35.71	
	MARRUG	Marbella Rug	Taupe	60" L 90"D	\$378.00	\$540.00	
	MOBPIL	Mongolian Faux Fur Pillow	Blue	18" L 18"H	\$30.00	\$42.86	
	MOGPIL	Mongolian Faux Fur Pillow	Gray	18" L 18"H	\$30.00	\$42.86	
	MONRUG	Montana Rug	Brindle Black/Brown	92" L 66"D	\$378.00	\$540.00	
	MORRUG	Morocco Rug	Orange, Sienna	96" L 120"D	\$295.00	\$421.43	
	MOVLAM	Movie Lamp 7"	Bronze, LED AC Lighted	36" RND 85" H	\$1,353.00	\$1,932.86	
	NILRUG	Nile Rug	Outdoor Distressed Multi-Color	63" L 87"D	\$283.00	\$404.29	
	OAHRRG	Oahu Rug	Green/Blue/Sienna	60" L 91"D	\$295.00	\$421.43	
	OMBPIL	Ombre Pillow	Blue	18" L 18"H	\$30.00	\$42.86	
	PALTRE	Palm Tree	Green, Black Base	15.75" L 15.75" D 84" H	\$620.00	\$885.71	

QTY	CODE	ITEM	DETAILS	DIMENSIONS	DISCOUNT PRICE	STANDARD PRICE	TOTAL
ACCESSORIES (continued)							
	PLADIV	Planter Divider	Bronze	47" L 175"D 31"H	\$620.00	\$885.71	
	PDFERN	Planter Divider w/ Ferns	Bronze, Green	47" L 175"D 46"H	\$758.00	\$1,082.86	
	PLAPOT	Planter Pot	Bronze	17.75"RND 39"H	\$403.00	\$575.71	
	PPFERN	Planter Pot w/ Fern	Bronze, Green	17.75"RND 60"H	\$460.00	\$657.14	
	PIL036	Regent Pillow	Marigold	23"L 23"H	\$58.00	\$82.86	
	PIL046	Solid Pillow	Earth Brown	20"L 20"H	\$58.00	\$82.86	
	PIL042	Solid Pillow	Fiesta Red	20"L 20"H	\$58.00	\$82.86	
	PIL044	Solid Pillow	Ivory	20"L 20"H	\$58.00	\$82.86	
	PIL045	Solid Pillow	Moss Green	20"L 20"H	\$58.00	\$82.86	
	PIL043	Solid Pillow	Pumpkin Spice	20"L 20"H	\$58.00	\$82.86	
	PIL041	Solid Pillow	Riverside Blue	20"L 20"H	\$58.00	\$82.86	
	SPLPIL	Splendor Pillow	Green/Black	17"L 17"H	\$25.00	\$35.71	
	STRPIL	Stripe Velvet Pillow	Rose/Brown	23"L 11"H	\$25.00	\$35.71	
	SUCBWL	Succulent Bowl	Wood, Green	10" RND 9"H	\$315.00	\$450.00	
	TBLPIL	Tribal Pillow	Blue	20"L 12"H	\$30.00	\$42.86	
	PIL048	Velvet Pillow	Plum	20"L 20"H	\$58.00	\$82.86	
	V SARUG	Visions Rug	Amethyst	60" L 90"D	\$283.00	\$404.29	
	VSSRUG	Visions Rug	Saffron	60" L 90"D	\$283.00	\$404.29	
	WWFPIL	Washed Waffle Pillow	Charcoal	18" L 18"H	\$63.00	\$90.00	
BARS							
	MTBLPI	Midtown Bar, Lighted w/ Plug In	Taupe Glass Top, Pewter	60" L 18"D 42"H	\$2,078.00	\$2,968.57	
	MTBUUL	Midtown Bar, Unlighted	Taupe Glass Top, Pewter	60" L 18"D 42"H	\$1,940.00	\$2,771.43	
	MAX606	Maxim Bar, Dry	Barnwood Finish, Black Frame, Shelf Only	72" L 24"D 41"H	\$1,665.00	\$2,378.57	
	MAX600	Maxim Bar, Dry	Black Gloss, Black Frame, w/ Shelf Only	72" L 24"D 41"H	\$1,665.00	\$2,378.57	
	MAX617	Maxim Bar, Dry	Black/Gold Marble, Black Frame, w/ Shelf Only	72" L 24"D 41"H	\$1,665.00	\$2,378.57	
	MAX619	Maxim Bar, Dry	Gray Marble, Black Frame, Shelf Only	72" L 24"D 41"H	\$1,665.00	\$2,378.57	
	MAX605	Maxim Bar, Dry	White Gloss, Black Frame, Shelf Only	72" L 24"D 41"H	\$1,665.00	\$2,378.57	
	MAX618	Maxim Bar, Dry	White Marble, Black Frame, Shelf Only	72" L 24"D 41"H	\$1,665.00	\$2,378.57	
	MAX704	Maxim Bar, Dry, LED Lighted	Barnwood Finish, Black Frame, Shelf Only	72" L 24"D 41"H	\$1,940.00	\$2,771.43	
	MAX700	Maxim Bar, Dry, LED Lighted	Black Gloss, Black Frame, Shelf Only	72" L 24"D 41"H	\$1,940.00	\$2,771.43	
	MAX620	Maxim Bar, Dry, LED Lighted	Black/Gold Marble, Black Frame, Shelf Only	72" L 24"D 41"H	\$1,940.00	\$2,771.43	
	MAX622	Maxim Bar, Dry, LED Lighted	Gray Marble, Black Frame, Shelf Only	72" L 24"D 41"H	\$1,940.00	\$2,771.43	
	MAX701	Maxim Bar, Dry, LED Lighted	White Gloss, Black Frame, Shelf Only	72" L 24"D 41"H	\$1,940.00	\$2,771.43	
	MAX621	Maxim Bar, Dry, LED Lighted	White Marble, Black Frame, Shelf Only	72" L 24"D 41"H	\$1,940.00	\$2,771.43	
	MAX616	Maxim Bar, Wet	Barnwood Finish, Black Frame, w/ Cutting Board & Ice Bucket	72" L 24"D 41"H	\$1,665.00	\$2,378.57	
	MAX610	Maxim Bar, Wet	Black Gloss, Black Frame, w/ Cutting Board & Ice Bucket	72" L 24"D 41"H	\$1,665.00	\$2,378.57	
	MAX623	Maxim Bar, Wet	Black/Gold Marble, Black Frame, w/ Cutting Board & Ice Bucket	72" L 24"D 41"H	\$1,665.00	\$2,378.57	
	MAX625	Maxim Bar, Wet	Gray Marble, Black Frame, w/ Cutting Board & Ice Bucket	72" L 24"D 41"H	\$1,665.00	\$2,378.57	
	MAX615	Maxim Bar, Wet	White Gloss, Black Frame, w/ Cutting Board & Ice Bucket	72" L 24"D 41"H	\$1,665.00	\$2,378.57	
	MAX624	Maxim Bar, Wet	White Marble, Black Frame, w/ Cutting Board & Ice Bucket	72" L 24"D 41"H	\$1,665.00	\$2,378.57	
	MAX709	Maxim Bar, Wet, LED Lighted	Barnwood Finish, Black Frame, w/ Cutting Board & Ice Bucket	72" L 24"D 41"H	\$1,940.00	\$2,771.43	
	MAX705	Maxim Bar, Wet, LED Lighted	Black Gloss, Black Frame, w/ Cutting Board & Ice Bucket	72" L 24"D 41"H	\$1,940.00	\$2,771.43	
	MAX626	Maxim Bar, Wet, LED Lighted	Black/Gold Marble, Black Frame, w/ Cutting Board & Ice Bucket	72" L 24"D 41"H	\$1,940.00	\$2,771.43	
	MAX628	Maxim Bar, Wet, LED Lighted	Gray Marble, Black Frame, w/ Cutting Board & Ice Bucket	72" L 24"D 41"H	\$1,940.00	\$2,771.43	
	MAX706	Maxim Bar, Wet, LED Lighted	White Gloss, Black Frame, w/ Cutting Board & Ice Bucket	72" L 24"D 41"H	\$1,940.00	\$2,771.43	
	MAX627	Maxim Bar, Wet, LED Lighted	White Marble, Black Frame, w/ Cutting Board & Ice Bucket	72" L 24"D 41"H	\$1,940.00	\$2,771.43	
	MBCLWB	Midtown Bar Circle, Lighted w/ Battery	3 Midtown Bars	87"RND 42"H	\$7525.00	\$10,750.00	
	MBCLPI	Midtown Bar Circle, Lighted w/ Plug In	3 Midtown Bars	87"RND 42"H	\$7525.00	\$10,750.00	
	MBCUNL	Midtown Bar Circle, Unlighted	3 Midtown Bars	87"RND 42"H	\$6,713.00	\$9,590.00	
	MTBLWB	Midtown Bar, Lighted w/ Battery	Taupe Glass Top, Pewter	60" L 18"D 42"H	\$2,518.00	\$3,597.14	
	PSHCAA	Posh 6' Bar, LED Lighted w/ AC Plug	Chrome, Acrylic	72" L 30"D 40.25"H	\$1,383.00	\$1,975.71	
	PSHCAL	Posh 6' Bar, LED Lighted w/ DC Battery	Chrome, Acrylic	72" L 30"D 40.25"H	\$1,383.00	\$1,975.71	
	PSHCAU	Posh 6' Bar, Unlighted	Chrome, Acrylic	72" L 30"D 40.25"H	\$1,258.00	\$1,797.14	
	PSHBFA	Posh 6' Buffet, LED Lighted w/ AC Plug	Chrome, Acrylic	72" L 30"D 40.25"H	\$1,383.00	\$1,975.71	
	PSHBFL	Posh 6' Buffet, LED Lighted w/ DC Battery	Chrome, Acrylic	72" L 30"D 40.25"H	\$1,383.00	\$1,975.71	
	PSHBFU	Posh 6' Buffet, Unlighted	Chrome, Acrylic	72" L 30"D 40.25"H	\$1,258.00	\$1,797.14	
	PSHCCA	Posh Corner Bar Pedestal, LED Lighted w/ AC Plug	Chrome, Acrylic	30" L 30"D 40.25"H	\$558.00	\$797.14	
	PSHCCB	Posh Corner Bar Pedestal, LED Lighted w/ DC Battery	Chrome, Acrylic	30" L 30"D 40.25"H	\$558.00	\$797.14	
	PSHCCU	Posh Corner Bar Pedestal, Unlighted	Chrome, Acrylic	30" L 30"D 40.25"H	\$408.00	\$582.86	
BARSTOOLS							
	KABSWH	Kamden Barstool	Chrome Base, White Vinyl	16.5" L 19"D 25" -33.5"	\$440.00	\$628.57	
	BSS	Banana Barstool	Black, Chrome	21" L 22"D 41"H	\$318.00	\$454.29	
	BST	Banana Barstool	White, Chrome	21" L 22"D 41"H	\$318.00	\$454.29	
	BLDBBK	Blade Barstool	Black Molded Plastic	20.5" L 20"D 40.5"H	\$188.00	\$268.57	
	BLDBRD	Blade Barstool	Red Molded Plastic	20.5" L 20"D 40.5"H	\$188.00	\$268.57	
	BLDBSB	Blade Barstool	Sky Blue Molded Plastic	20.5" L 20"D 40.5"H	\$188.00	\$268.57	
	CBSBAZ	Chelsea Barstool	Black Tower Base, Azure Blue	18.5" L 22"D 46"H	\$198.00	\$282.86	
	CBSBBK	Chelsea Barstool	Black Tower Base, Black	18.5" L 22"D 46"H	\$198.00	\$282.86	
	CBSBYL	Chelsea Barstool	Black Tower Base, Goldenrod Yellow	18.5" L 22"D 46"H	\$198.00	\$282.86	
	CBSBGY	Chelsea Barstool	Black Tower Base, Gray	18.5" L 22"D 46"H	\$198.00	\$282.86	
	CBSBOR	Chelsea Barstool	Black Tower Base, Orange	18.5" L 22"D 46"H	\$198.00	\$282.86	
	CBSBWL	Chelsea Barstool	Black Tower Base, Walnut-look	18.5" L 22"D 46"H	\$198.00	\$282.86	
	XBAR	Christopher Barstool	White Vinyl, Chrome	19" L 19"D 41"H	\$230.00	\$328.57	
	LMBAR	Laguna Barstool	Maple, Chrome	18" L 20"D 47"H	\$235.00	\$335.71	
	ROLLBL	Lift Barstool	Black Vinyl, Chrome	15"RND 23-33.5"H	\$270.00	\$385.71	
	ROLLGY	Lift Barstool	Gray Vinyl, Chrome	15"RND 23-33.5"H	\$270.00	\$385.71	
	ROLLRD	Lift Barstool	Red Vinyl, Chrome	15"RND 23-33.5"H	\$270.00	\$385.71	
	ROLLWH	Lift Barstool	White Vinyl, Chrome	15"RND 23-33.5"H	\$270.00	\$385.71	
	LUBSCL	Lucent Barstool	Frosted Acrylic, Chrome	22" L 22.5"D 45.5"H	\$358.00	\$511.43	
	MARBBK	Marina Barstool	Black Vinyl, Brushed Metal	21" L 17.5"D 41.5"H	\$428.00	\$611.43	
	MARBBR	Marina Barstool	Brown Fabric, Brushed Metal	21" L 17.5"D 41.5"H	\$428.00	\$611.43	
	MARBBE	Marina Barstool	Ocean Blue Fabric, Brushed Metal	21" L 17.5"D 41.5"H	\$428.00	\$611.43	
	MARBRD	Marina Barstool	Red Fabric, Brushed Metal	21" L 17.5"D 41.5"H	\$428.00	\$611.43	
	MARBWH	Marina Barstool	White Vinyl, Brushed Metal	21" L 17.5"D 41.5"H	\$428.00	\$611.43	

QTY	CODE	ITEM	DETAILS	DIMENSIONS	DISCOUNT PRICE	STANDARD PRICE	TOTAL
BARSTOOLS (continued)							
	RSTSTL	Rustique Barstool	Gunmetal	13"L 13"D 30"H	\$148.00	\$211.43	
	BS001	Shark Barstool	White, Chrome	22"L 19"D 34-44"H	\$410.00	\$585.71	
	BSR	Syntax Barstool	Black, Chrome	23"L 19"D 43.25"H	\$235.00	\$335.71	
	ZENBAR	Zenith Barstool	White, Chrome	19"L 20"D 44"H	\$198.00	\$282.86	
	BS002	Zoey Barstool	White, Chrome	15"L 16"D 30-34.75"H	\$280.00	\$400.00	
	CBSBWH	Chelsea Barstool	Black Tower Base, White	18.5"L 22"D 46"H	\$198.00	\$282.86	
	CBSOAZ	Chelsea Barstool	Oak Tower Base, Azure Blue	18.5"L 22"D 46"H	\$198.00	\$282.86	
	CBSOBK	Chelsea Barstool	Oak Tower Base, Black	18.5"L 22"D 46"H	\$198.00	\$282.86	
	CBSOYL	Chelsea Barstool	Oak Tower Base, Goldenrod Yellow	18.5"L 22"D 46"H	\$198.00	\$282.86	
	CBSOGY	Chelsea Barstool	Oak Tower Base, Gray	18.5"L 22"D 46"H	\$198.00	\$282.86	
	CBSOOR	Chelsea Barstool	Oak Tower Base, Orange	18.5"L 22"D 46"H	\$198.00	\$282.86	
	CBSOWL	Chelsea Barstool	Oak Tower Base, Walnut-look	18.5"L 22"D 46"H	\$198.00	\$282.86	
	CBSOWH	Chelsea Barstool	Oak Tower Base, White	18.5"L 22"D 46"H	\$198.00	\$282.86	
	BSTLIB	Liberty Barstool	White, Black Plastic	17"RND 29"H	\$350.00	\$500.00	
CHAIRS							
	ACHBCB	Ace High Back Chair	Black Vinyl, Chrome	26"L 26"D 42.25-44"H	\$415.00	\$592.86	
	ACMBCB	Ace Mid Back Chair	Black Vinyl, Chrome	26"L 26"D 33.25-33.75"H	\$385.00	\$550.00	
	TRCHCO	Terrace Accent Chair	Black Base, Cognac Leather	24"L 30.5"D 31.25"H	\$815.00	\$1,164.29	
	ARCHGY	Aruba Lounge Chair	Charcoal, Caning	42"L 43.5"D 59.75"H	\$815.00	\$1,164.29	
	ARCHGN	Aruba Lounge Chair	Fern Green, Caning	42"L 43.5"D 59.75"H	\$815.00	\$1,164.29	
	LYCHGN	Lyon Chair	Sage Green	21.5"L 20.5"D 30.5"H	\$133.00	\$190.00	
	LYCHSD	Lyon Chair	Warm Sand	21.5"L 20.5"D 30.5"H	\$133.00	\$190.00	
	ACEHBC	Ace High Back Chair	White Vinyl, Chrome	26"L 26"D 42.25-44"H	\$415.00	\$592.86	
	ACEMBC	Ace Mid Back Chair	White Vinyl, Chrome	26"L 26"D 33.25-33.75"H	\$385.00	\$550.00	
	CHRO02	Allegro Chair	Blue Fabric, Brushed Metal	36"L 34.5"D 30"H	\$633.00	\$904.29	
	ATHCHA	Atherton Chair	Brown Leather, Black Metal	27"L 31"D 30"H	\$833.00	\$1,190.00	
	BCHWHT	Baja Chair	White Vinyl	36"L 30.5"D 28"H	\$645.00	\$921.43	
	BLDCBK	Blade Chair	Black Molded Plastic	20.5"L 19"D 30.5"H	\$100.00	\$142.86	
	BLDCRD	Blade Chair	Red Molded Plastic	20.5"L 19"D 30.5"H	\$100.00	\$142.86	
	BLDCSB	Blade Chair	Sky Blue Molded Plastic	20.5"L 19"D 30.5"H	\$100.00	\$142.86	
	BOWCHA	Bowery Chair	Ochre Fabric	29.75"L 31"D 27.25"H	\$778.00	\$1,111.43	
	SC3	Brewer Chair	Onyx, Chrome	20"L 20"D 32"H	\$225.00	\$321.43	
	BNMCSB	Brooklyn Meeting Chair	Black Vinyl, Black Swivel Base	24.5"L 25.5"D 31.75"H	\$428.00	\$611.43	
	BNMCOB	Brooklyn Meeting Chair	Black Vinyl, Oak-look Base	24.5"L 25.5"D 31.75"H	\$428.00	\$611.43	
	BNMCSW	Brooklyn Meeting Chair	White Vinyl, Black Swivel Base	24.5"L 25.5"D 31.75"H	\$470.00	\$671.43	
	BNMCOW	Brooklyn Meeting Chair	White Vinyl, Oak-look	24.5"L 25.5"D 31.75"H	\$470.00	\$671.43	
	CNTCHR	Century Chair	Gray Velvet	30"L 30"D 31"H	\$795.00	\$1,135.71	
	CCSCAZ	Chelsea Chair	Black Swivel Base w/ Casters, Azure Blue	18.5"L 22"D 34"H	\$180.00	\$257.14	
	CCSCBK	Chelsea Chair	Black Swivel Base w/ Casters, Black	18.5"L 22"D 34"H	\$180.00	\$257.14	
	CCSCYL	Chelsea Chair	Black Swivel Base w/ Casters, Goldenrod Yellow	18.5"L 22"D 34"H	\$180.00	\$257.14	
	CCSCGY	Chelsea Chair	Black Swivel Base w/ Casters, Gray	18.5"L 22"D 34"H	\$180.00	\$257.14	
	CCSCOR	Chelsea Chair	Black Swivel Base w/ Casters, Orange	18.5"L 22"D 34"H	\$180.00	\$257.14	
	CCSCWL	Chelsea Chair	Black Swivel Base w/ Casters, Walnut-look	18.5"L 22"D 34"H	\$180.00	\$257.14	
	CCBTAZ	Chelsea Chair	Black Tower Base, Azure Blue	18.5"L 22"D 34"H	\$180.00	\$257.14	
	CCBTBK	Chelsea Chair	Black Tower Base, Black	18.5"L 22"D 34"H	\$180.00	\$257.14	
	CCBTYL	Chelsea Chair	Black Tower Base, Goldenrod Yellow	18.5"L 22"D 34"H	\$180.00	\$257.14	
	CCBTGY	Chelsea Chair	Black Tower Base, Gray	18.5"L 22"D 34"H	\$180.00	\$257.14	
	CCBTOR	Chelsea Chair	Black Tower Base, Orange	18.5"L 22"D 34"H	\$180.00	\$257.14	
	CCBTWL	Chelsea Chair	Black Tower Base, Walnut-look	18.5"L 22"D 34"H	\$180.00	\$257.14	
	XCHR	Christopher Chair	White Vinyl, Chrome	17"L 19"D 35"H	\$133.00	\$190.00	
	CUPCHA	Cupertino Mid Back Chair	Black Vinyl	27"L 30.5"D 40-43"H	\$390.00	\$557.14	
	DUET	Duet Stack Chair	Black, Chrome	21"L 23"D 33"H	\$83.00	\$118.57	
	FAIRCW	Fairfax Chair	White Vinyl, Brushed Metal	27"L 26"D 30"H	\$445.00	\$635.71	
	GENCHA	Genesis Chair	Black	27.5"L 27.5"D 40-43.5"H	\$340.00	\$485.71	
	KEYCHR	Key Largo Chair	Black Fabric, Wood	35"L 35"D 34"H	\$403.00	\$575.71	
	LABREA	La Brea Swivel Chair	Charcoal Gray Fabric, Chrome	35"L 27"D 40"H	\$530.00	\$757.14	
	LMCHR	Laguna Chair	Maple, Chrome	18"L 19"D 34"H	\$193.00	\$275.71	
	LENCHA	Lena Chair	Moss Green Leather, Bronze	27"L 25"D 31"H	\$700.00	\$1,000.00	
	LUCHCL	Lucent Chair	Frosted Acrylic, Chrome	19.5"L 19.75"D 32.5"H	\$253.00	\$361.43	
	BCW	Madrid Chair	White Vinyl, Chrome	30"L 30"D 31"H	\$825.00	\$1,178.57	
	MALGRY	Malba Chair	Gray, Chrome	20"L 20"D 32"H	\$145.00	\$207.14	
	MALGRN	Malba Chair	Green, Chrome	20"L 20"D 32"H	\$145.00	\$207.14	
	MARCBK	Marina Chair	Black Vinyl, Brushed Metal	17.5"L 19.5"D 35"H	\$203.00	\$290.00	
	MARCBR	Marina Chair	Brown Fabric, Brushed Metal	17.5"L 19.5"D 35"H	\$203.00	\$290.00	
	MARCBE	Marina Chair	Ocean Blue Fabric, Brushed Metal	17.5"L 19.5"D 35"H	\$203.00	\$290.00	
	MARCRD	Marina Chair	Red Fabric, Brushed Metal	17.5"L 19.5"D 35"H	\$203.00	\$290.00	
	MARCWH	Marina Chair	White Vinyl, Brushed Metal	17.5"L 19.5"D 35"H	\$203.00	\$290.00	
	OCMWHT	Meeting Chair	White Vinyl, Wenge	25.5"L 23.5"D 34"H	\$350.00	\$500.00	
	MONCHA	Montreal Chair	Blue, Black Metal	30"L 23.25"D 30"H	\$855.00	\$1,221.43	
	MNCHCH	Munich Armless Chair	Gray Fabric, Black	22.5"L 27"D 28.5"H	\$633.00	\$904.29	
	NPLCHR	Naples Chair	Black Vinyl	36"L 30"D 33.25"H	\$750.00	\$1,071.43	
	PASCHR	Pasadena Chair	White Molded Plastic w/Chrome Tower Base	27"L 25"D 26"H	\$483.00	\$690.00	
	PROGB	Pro Executive Guest Chair	Black Vinyl, Chrome	24"L 26"D 36"H	\$413.00	\$590.00	
	SCIO	Razor Armless Chair	White	19"L 23.5"D 31.75"H	\$93.00	\$132.86	
	RSTDIN	Rustique Chair w/ Arms	Gunmetal	20"L 18"D 31"H	\$135.00	\$192.86	
	STECOA	Sterling Chair	Gray Fabric	33"L 33.5"D 32"H	\$1,108.00	\$1,582.86	
	SWAN	Swanson Swivel Chair	White Vinyl, Chrome	28"L 25"D 30"H	\$460.00	\$657.14	
	CS4	Syntax Chair	Black, Chrome	23"L 19"D 32.25"H	\$275.00	\$392.86	
	TASKST	Task Stool	Black Fabric, Black	27.5"L 27.5"D 32.75"-40.25"H	\$203.00	\$290.00	
	VALCHA	Valencia Chair	Spice Orange Velvet	28"L 30.5"D 31"H	\$493.00	\$704.29	
	WENCHA	Wentworth Swivel Chair	Brown Vinyl	31"L 24"D 31.5"H	\$460.00	\$657.14	
	ZENCHR	Zenith Chair	White, Chrome	18.25"L 22"D 32"H	\$180.00	\$257.14	
	ACDGUE	Arcadia Guest Chair	Distressed Taupe Vinyl, Chrome	26"L 31.5"D 38"H	\$303.00	\$432.86	
	ACDMBA	Arcadia Mid Back Executive Chair	Distressed Taupe Vinyl, Chrome	27.5"L 31.5"D 39-41.5"H	\$353.00	\$504.29	

QTY	CODE	ITEM	DETAILS	DIMENSIONS	DISCOUNT PRICE	STANDARD PRICE	TOTAL
CHAIRS (continued)							
	BOCAC	Boca Armless Chair	Brown, Tan Cushions	28"L 33"D 25.5"H	\$460.00	\$657.14	
	BOCCC	Boca Corner Chair	Brown, Tan Cushions	33"L 33"D 25.5"H	\$518.00	\$740.00	
	CHACHA	Chandler Chair	Plum Fabric	40"L 34.5"D 31"H	\$1,060.00	\$1,514.29	
	CCSCWH	Chelsea Chair	Black Swivel Base w/ Casters, White	18.5"L 22"D 34"H	\$180.00	\$257.14	
	CCBTWH	Chelsea Chair	Black Tower Base, White	18.5"L 22"D 34"H	\$180.00	\$257.14	
	CCOTAZ	Chelsea Chair	Oak Tower Base, Azure Blue	18.5"L 22"D 34"H	\$180.00	\$257.14	
	CCOTBK	Chelsea Chair	Oak Tower Base, Black	18.5"L 22"D 34"H	\$180.00	\$257.14	
	CCOTYL	Chelsea Chair	Oak Tower Base, Goldenrod Yellow	18.5"L 22"D 34"H	\$180.00	\$257.14	
	CCOTGY	Chelsea Chair	Oak Tower Base, Gray	18.5"L 22"D 34"H	\$180.00	\$257.14	
	CCOTOR	Chelsea Chair	Oak Tower Base, Orange	18.5"L 22"D 34"H	\$180.00	\$257.14	
	CCOTWL	Chelsea Chair	Oak Tower Base, Walnut-look	18.5"L 22"D 34"H	\$180.00	\$257.14	
	CCOTWH	Chelsea Chair	Oak Tower Base, White	18.5"L 22"D 34"H	\$180.00	\$257.14	
	ESD2IW	Endless Dining Large Curve High Back Chair	White	60.5"L 38.5"D 50"H	\$1,393.00	\$1,990.00	
	ESD18B	Endless Dining Large Curve Low Back Chair	Black	60.5"L 38.5"D 30"H	\$1,245.00	\$1,778.57	
	ESD18W	Endless Dining Large Curve Low Back Chair	White	60.5"L 38.5"D 30"H	\$1,245.00	\$1,778.57	
	EDC01B	Endless Dining Low Back Corner Chair	Black	34.5"L 34.5"D 30"H	\$905.00	\$1,292.86	
	EDC01W	Endless Dining Low Back Corner Chair	White	34.5"L 34.5"D 30"H	\$905.00	\$1,292.86	
	ESD15W	Endless Dining Small Curve High Back Chair	White	60.5"L 38.5"D 50"H	\$1,393.00	\$1,990.00	
	ESD12B	Endless Dining Small Curve Low Back Chair	Black	60.5"L 38.5"D 30"H	\$1,245.00	\$1,778.57	
	ESD12W	Endless Dining Small Curve Low Back Chair	White	60.5"L 38.5"D 30"H	\$1,245.00	\$1,778.57	
	ESD06B	Endless Dining Square Low Back Chair	Black	34"L 34.5"D 30"H	\$820.00	\$1,171.43	
	ESD06W	Endless Dining Square Low Back Chair	White	34"L 34.5"D 30"H	\$820.00	\$1,171.43	
	EHLCEC	Endless Half Round Low Back Chair	Emerald Velvet Channel Stitch, Black Frame	34.5"L 34.5"D 27"H	\$945.00	\$1,350.00	
	EHLWCW	Endless Half Round Low Back Chair	White Vinyl Channel Stitch, Black Frame	34.5"L 34.5"D 27"H	\$945.00	\$1,350.00	
	END21W	Endless Large Curve High Back Chair	White	60.5"L 38.5"D 47"H	\$1,393.00	\$1,990.00	
	END18B	Endless Large Curve Low Back Chair	Black	60.5"L 38.5"D 27"H	\$1,245.00	\$1,778.57	
	ECLCEC	Endless Large Curve Low Back Chair	Emerald Velvet Channel Stitch, Black Frame	60.5"L 38.5"D 27"H	\$1,245.00	\$1,778.57	
	END18W	Endless Large Curve Low Back Chair	White	60.5"L 38.5"D 27"H	\$1,245.00	\$1,778.57	
	ECLWCW	Endless Large Curve Low Back Chair	White Vinyl Channel Stitch, Black Frame	60.5"L 38.5"D 27"H	\$1,245.00	\$1,778.57	
	ESC01B	Endless Low Back Corner Chair	Black	34.5"L 34.5"D 27"H	\$905.00	\$1,292.86	
	ESC01W	Endless Low Back Corner Chair	White	34.5"L 34.5"D 27"H	\$905.00	\$1,292.86	
	END15W	Endless Small Curve High Back Chair	White	60.5"L 38.5"D 47"H	\$1,393.00	\$1,990.00	
	END12B	Endless Small Curve Low Back Chair	Black	60.5"L 38.5"D 27"H	\$1,245.00	\$1,778.57	
	END12W	Endless Small Curve Low Back Chair	White	60.5"L 38.5"D 27"H	\$1,245.00	\$1,778.57	
	END06B	Endless Square Low Back Chair	Black	34"L 34.5"D 27"H	\$820.00	\$1,171.43	
	ESLCEC	Endless Square Low Back Chair	Emerald Velvet Channel Stitch, Black Frame	34.5"L 34.5"D 27"H	\$820.00	\$1,171.43	
	END06W	Endless Square Low Back Chair	White	34"L 34.5"D 27"H	\$820.00	\$1,171.43	
	ESLWCW	Endless Square Low Back Chair	White Vinyl Channel Stitch, Black Frame	34.5"L 34.5"D 27"H	\$820.00	\$1,171.43	
	MALCHA	Malibu Chair	Teal Velvet	36"L 31"D 42"H	\$728.00	\$1,040.00	
	MNCHCC	Munich Corner Chair	Gray Fabric, Black	26"L 27"D 28.5"H	\$650.00	\$928.57	
	WAGCHR	Wagner Chair	Cream Fur	31"L 35"D 35.5"H	\$723.00	\$1,032.86	
COLUMNS							
	PC60AC	Posh Column, 62"	LED Lighted w/ AC Plug	18"L 18"W 60"H	\$1,165.00	\$1,664.29	
	PC60DC	Posh Column, 62"	LED Lighted w/ DC	18"L 18"W 60"H	\$1,165.00	\$1,664.29	
	PC60UL	Posh Column, 62"	Unlit	18"L 18"W 60"H	\$670.00	\$957.14	
	PC80AC	Posh Column, 84"	LED Lighted w/ AC Plug	18"L 18"W 80"H	\$1,335.00	\$1,907.14	
	PC80DC	Posh Column, 84"	LED Lighted w/ DC	18"L 18"W 80"H	\$1,335.00	\$1,907.14	
	PC80UL	Posh Column, 84"	Unlit	18"L 18"W 80"H	\$818.00	\$1,168.57	
COUNTER							
	MTCLPI	Midtown Powered Counter, Lighted w/ Plug In	Taupe Glass Top, Pewter	60"L 18"D 42"H	\$2,200.00	\$3,142.86	
	MTCPUL	Midtown Powered Counter, Unlighted	Taupe Glass Top, Pewter	60"L 18"D 42"H	\$1,955.00	\$2,792.86	
	MAC300	Maxim Counter	Black Gloss, Black Frame	36"L 24"D 41"H	\$825.00	\$1,178.57	
	MAC301	Maxim Counter	White Gloss, Black Frame	36"L 24"D 41"H	\$825.00	\$1,178.57	
	MPCCWB	Midtown Powered Counter Circle, Lighted w/ Battery	3 Midtown Powered Counters	87"RND 42"H	\$7525.00	\$10,750.00	
	MPCCPI	Midtown Powered Counter Circle, Lighted w/ Plug In	3 Midtown Powered Counters	87"RND 42"H	\$7525.00	\$10,750.00	
	MPCCUL	Midtown Powered Counter Circle, Unlighted	3 Midtown Powered Counters	87"RND 42"H	\$7200.00	\$10,171.43	
	MTCLWB	Midtown Powered Counter, Lighted w/ Battery	Pewter	60"L 18"D 42"H	\$2,518.00	\$3,597.14	
DIVIDERS							
	DIVBAR	Clear Divider, Bar/Counter	Clear, Black	48-70"L 12"D 31.5"H	\$258.00	\$368.57	
	DIVFRE	Clear Divider, Freestanding	Silver, Clear	39"L 1.5"D 72"H	\$518.00	\$740.00	
	DIVFCR	Clear Divider, Freestanding Corner	Silver, Clear	39"L 39"D 72"H	\$1,038.00	\$1,482.86	
	DIVFWL	Clear Divider, Freestanding Wall	Silver, Clear	40"L 1.5"D 72"H	\$518.00	\$740.00	
	DIVFST	Clear Divider, Sofa/Table	Silver, Clear	34"L 11"D 47-74"H	\$465.00	\$664.29	
	DIVFWB	Divider, Freestanding Whiteboard	Silver, White	39"L 1.5"D 72"H	\$648.00	\$925.71	
	MIRWHT	Miramar Divider, White	Molded Plastic	63"L 23"D 83"H	\$663.00	\$947.14	
LOGOS							
	LGADCP	Adelaide Powered Cocktail Table Logo	Adelaide Powered Cocktail Tabletop		\$365.00	\$521.43	
	LGARUB	Aruba Accent Chair Cushion Fabric Cover	Slipcover Logo for the Aruba Accent Chair Cushion		\$638.00	\$911.43	
	LGBOCA	Boca Armless Chair Fabric Cover Set	Slipcover Logo for Boca Armless Chair Back and Seat Cushions		\$735.00	\$1,050.00	
	LGBOCC	Boca Corner Chair Fabric Cover Set	Slipcover Logo for Boca Corner Chair Back and Seat Cushions		\$930.00	\$1,328.57	
	LGBCSV	Boho Stool Fabric Cover	Boho Stool Slipcover		\$335.00	\$478.57	
	LGPLLG	Custom Branded Pillow, Large	Large pillows with a custom color or graphic		\$220.00	\$314.29	
	LGPLLM	Custom Branded Pillow, Lumbar	Lumbar-shaped pillows with a custom color or graphic		\$125.00	\$178.57	
	LGPC6A	Posh Column, 62" Logo, All Sides	Posh 60" Column (Four Sides Only, No Top)		\$988.00	\$1,411.43	
	LGPC6S	Posh Column, 62" Logo, Side	Posh 60" Column (One Side Only)		\$245.00	\$350.00	
	LGPC8A	Posh Column, 84" Logo, All Sides	Posh 80" Column (Four Sides Only, No Top)		\$1,288.00	\$1,840.00	
	LGPC8S	Posh Column, 84" Logo, Side	Posh 80" Column (One Side Only)		\$320.00	\$457.14	
	LGPPTP	Posh Pedestal Top Logo	Posh Pedestal and Column Top		\$95.00	\$135.71	
	LGPP2A	Posh Pedestal, 20" Logo, All Sides and Top	Posh 20" Pedestal (Four Sides and Top)		\$463.00	\$661.43	
	LGPP2S	Posh Pedestal, 20" Logo, One Side	Posh 20" Pedestal (One Side Only)		\$95.00	\$135.71	
	LGPP4A	Posh Pedestal, 42" Logo, All Sides and Top	Posh 40" Pedestal (Four Sides and Top)		\$763.00	\$1,090.00	
	LGPP4S	Posh Pedestal, 42" Logo, One Side	Posh 40" Pedestal (One Side Only)		\$170.00	\$242.86	
	LGSWAN	Swanson Swivel Chair Fabric Cover	Slipcover Logo		\$720.00	\$1,028.57	
	LG10X4	10' Conference Table Logo	10' Conference Tables		\$1,553.00	\$2,218.57	

QTY	CODE	ITEM	DETAILS	DIMENSIONS	DISCOUNT PRICE	STANDARD PRICE	TOTAL
LOGOS (continued)							
	LGW104	10' Conference Table Whiteboard	10' Conference Tables		\$1,855.00	\$2,650.00	
	LGP104	10' Powered Conference Table Logo	10' Powered Conference Tables		\$1,553.00	\$2,218.57	
	LWP104	10' Powered Conference Table Whiteboard	10' Powered Conference Tables		\$2,280.00	\$3,257.14	
	20RND	20.5" Round Logo	Mesa End Table (Black, Barnwood)		\$185.00	\$264.29	
	20RWLG	20.5" Round Whiteboard	Mesa End Table (Black, Barnwood)		\$213.00	\$304.29	
	24RND	24" Round Top Logo	Mesa Glass, Silverado Glass and Brisbane Side Table (Glass)		\$200.00	\$285.71	
	24RWLG	24" Round Whiteboard	Silverado End Table, Mesa End Table (Glass), Brisbane Side Table (Glass)		\$230.00	\$328.57	
	LG030P	30" Round Power Table Logo	30" Round Powered Bar and Cafe Table		\$328.00	\$468.57	
	LG30PW	30" Round Power Table Whiteboard	30" Powered Bar and Cafe Table		\$435.00	\$621.43	
	LG030	30" Round Top Logo	30" Round Bar and Cafe Tables		\$340.00	\$485.71	
	30RWLG	30" Round Top Whiteboard	30" Round Bar and Cafe Tables		\$285.00	\$407.14	
	32RLG	32" Round Logo	Mesa Cocktail Table (Black, Barnwood)		\$340.00	\$485.71	
	32RWLG	32" Round Whiteboard	Mesa Cocktail Table (Black, Barnwood)		\$470.00	\$671.43	
	36RND	36" Round Top Logo	Silverado Cocktail, 36" Rnd Tables		\$445.00	\$635.71	
	36RWLG	36" Round Top Whiteboard	Silverado Cocktail, 36" Rnd Tables		\$435.00	\$621.43	
	42RND	42" Round Top Logo	42" Conference Tables, Atomic Tables		\$613.00	\$875.71	
	42RWLG	42" Round Whiteboard	42" Conference Tables, Atomic Tables		\$535.00	\$764.29	
	LGSX4	5' Conference Table Logo	5' Conference Tables		\$778.00	\$1,111.43	
	5X4WLG	5' Conference Table Whiteboard	5' Conference Table		\$928.00	\$1,325.71	
	LGP5X4	5' Powered Conference Table Logo	5' Powered Conference Tables		\$778.00	\$1,111.43	
	LGWP54	5' Powered Conference Table Whiteboard	5' Powered Conference Tables		\$1,140.00	\$1,628.57	
	LG8X5	8' Conference Table Logo	8' Conference Tables		\$1,553.00	\$2,218.57	
	LGW8X5	8' Conference Table Whiteboard	8' Conference Tables		\$1,855.00	\$2,650.00	
	LGP8X5	8' Powered Conference Table Logo	8' Powered Conference Tables		\$1,553.00	\$2,218.57	
	LGWP85	8' Powered Conference Table Whiteboard	8' Powered Conference Tables		\$2,280.00	\$3,257.14	
	LGAURA	Aura Table Logo	Aura Table		\$120.00	\$171.43	
	BNBALG	Banana Barstool Back and Seat Fabric Covers	Banana Barstool Slipcover Logo		\$350.00	\$500.00	
	BNBBLG	Banana Barstool Back Fabric Cover	Slipcover Logo		\$218.00	\$311.43	
	BNBSLG	Banana Barstool Seat Fabric Cover	Slipcover Logo		\$133.00	\$190.00	
	BEVLGO	Beverly Bench Ottoman Fabric Cover	Slipcover Logo		\$748.00	\$1,068.57	
	BVSBLG	Beverly Seat Back Fabric Cover	Slipcover Logo		\$605.00	\$864.29	
	BVSMLG	Beverly Small Ottoman Fabric Cover	Slipcover Logo		\$488.00	\$697.14	
	BVSQLG	Beverly Square Ottoman Fabric Cover	Slipcover Logo		\$555.00	\$792.86	
	BLBSLG	Blade Barstool Logo (Clear)	Back of Blade Barstool Back		\$63.00	\$90.00	
	BLCHLG	Blade Chair Logo (Clear)	Back of Blade Chair Back		\$63.00	\$90.00	
	BH4CLG	Boxwood Hedge 4' Logo, All Sides	Boxwood 4' Hedge Base		\$588.00	\$840.00	
	BH4LLG	Boxwood Hedge 4' Logo, Long Side	Boxwood 4' Hedge Base's Long Side		\$200.00	\$285.71	
	BH4SLG	Boxwood Hedge 4' Logo, Short Side	Boxwood 4' Hedge Base's Short Side		\$95.00	\$135.71	
	BH7CLG	Boxwood Hedge 7' Logo, All Sides	Boxwood 7' Hedge Base		\$530.00	\$757.14	
	BH7LLG	Boxwood Hedge 7' Logo, Long Side	Boxwood 7' Hedge Base's Long Side		\$170.00	\$242.86	
	BH7SLG	Boxwood Hedge 7' Logo, Short Side	Boxwood 7' Hedge Base's Short Side		\$95.00	\$135.71	
	LGBRAC	Brighton Armless Chair Fabric Cover	Slipcover Logo		\$1,453.00	\$2,075.71	
	LGBRCC	Brighton Corner Chair Fabric Cover	Slipcover Logo		\$1,810.00	\$2,585.71	
	LGBRLV	Brighton Loveseat Fabric Cover	Slipcover Logo		\$2,315.00	\$3,307.14	
	LOGOPL	Custom Branded Pillow	Pillows with a custom color or graphic		\$158.00	\$225.71	
	PLRFEE	Custom Pillow Rush Shipping Fee	Rush shipping fee for every 5 custom pillows.		\$375.00	\$535.71	
	PLSFEE	Custom Pillow Shipping Fee	Shipping fee for every 5 custom pillows.		\$113.00	\$161.43	
	LGDVBF	Divider, Bar/Counter Logo, Front Face	Translucent Logo for Full Front Face of Bar/Counter Clear Divider		\$638.00	\$911.43	
	LGDVBA	Divider, Bar/Counter Logo, Front Face & Sides	Translucent Logo for Full Front Face and Both Sides of Bar/Counter Clear Divider		\$960.00	\$1,371.43	
	LGDVBH	Divider, Bar/Counter Logo, Front Header	Translucent Logo for Front Header of Bar/Counter Clear Divider		\$103.00	\$147.14	
	LGDVBS	Divider, Bar/Counter Logo, Side	Translucent Logo for Front Header of Bar/Counter Clear Divider		\$190.00	\$271.43	
	LGDVFO	Divider, Freestanding Logo, Opaque	Opaque Logo for Freestanding Divider		\$563.00	\$804.29	
	LGDVFC	Divider, Freestanding Logo, Translucent	Translucent Logo for Freestanding Divider		\$765.00	\$1,092.86	
	LGDVSO	Divider, Sofa/Table Logo, Opaque	Opaque Logo for Sofa/Table Divider		\$340.00	\$485.71	
	LGDVSC	Divider, Sofa/Table Logo, Translucent	Translucent Logo for Sofa/Table Divider		\$403.00	\$575.71	
	ELCOLG	Endless Curve Ottoman Fabric Cover	Slipcover Logo		\$838.00	\$1,197.14	
	EHROLG	Endless Half Round Ottoman Fabric Cover	Slipcover Logo		\$455.00	\$650.00	
	ESQQLG	Endless Square Ottoman Fabric Cover	Slipcover Logo		\$505.00	\$721.43	
	ESGLGO	Endless Table Logo	Endless Table, Glass or Marble		\$133.00	\$190.00	
	CTGLLG	Glass Cocktail Table Top Logo	Adelaide, Alondra and Geo Cocktail Tables		\$340.00	\$485.71	
	CTGWLG	Glass Cocktail Table Top Whiteboard	Adelaide, Alondra and Geo Cocktail Tables		\$353.00	\$504.29	
	ETGLLG	Glass End Table Top Logo	Adelaide, Alondra and Geo Cocktail Tables		\$150.00	\$214.29	
	ETGWLG	Glass End Table Top Whiteboard	Adelaide, Alondra and Geo Cocktail Tables		\$185.00	\$264.29	
	GCPCLG	Grass Centerpiece Logo, All Sides	Grass Centerpiece		\$165.00	\$235.71	
	GCPSLG	Grass Centerpiece Logo, Long Side	Grass Centerpiece		\$63.00	\$90.00	
	GNCCLG	Greenery Cube Base Logo, All Sides	Bamboo, Palm Tree, Fiddle Leaf Tree Bases or Havana Palm, 6' Bases		\$530.00	\$757.14	
	GNSSLG	Greenery Cube Base Logo, Side	Bamboo, Palm Tree, Fiddle Leaf Tree Bases or Havana Palm, 6' Bases		\$133.00	\$190.00	
	LGHND2	Hand Sanitizer Station Logo Sign, Double-Sided	Hand Sanitizer Station Sign		\$153.00	\$218.57	
	LGHND1	Hand Sanitizer Station Logo Sign, Single-Sided	Hand Sanitizer Station Sign		\$78.00	\$111.43	
	LGHDW2	Hand Sanitizer Station Whiteboard Sign, Double-Sided	Hand Sanitizer Station Sign		\$190.00	\$271.43	
	LGHDW1	Hand Sanitizer Station Whiteboard Sign, Single-Sided	Hand Sanitizer Station Sign		\$95.00	\$135.71	
	HPDALG	Havana Palm Divider 8' Logo, All Sides	Havana Palm Divider, 7' Base's All Sides		\$743.00	\$1,061.43	
	HPDLLG	Havana Palm Divider 8' Logo, Long Side	Havana Palm Divider, 7' Base's Long Side		\$285.00	\$407.14	
	HPDSL	Havana Palm Divider 8' Logo, Short Side	Havana Palm Divider, 7' Base's Short Side		\$85.00	\$121.43	
	LTBSLG	Lift Barstool Fabric Cover	Slipcover Logo		\$85.00	\$121.43	
	LGSID	Logo Last Minute Shipping Fee	Within 3 business days		\$500.00	\$714.29	
	LGRFEE	Logo Rush Set Up Fee	Rush logo set up fee.		\$125.00	\$178.57	
	LGS2D	Logo Rush Shipping Fee			\$363.00	\$518.57	
	LGPTEE	Logo Setup Fee	1 setup fee per order		\$100.00	\$142.86	
	LGSHP	Logo Shipping Fee	Standard timeline, 10 business days		\$123.00	\$175.71	
	WIRFEE	Logo White Ink Rush Printing Fee	Rush white ink setup fee. Required for any logo/branding artwork on the Acrylic Podium and Metal Lectern.		\$188.00	\$268.57	

QTY	CODE	ITEM	DETAILS	DIMENSIONS	DISCOUNT PRICE	STANDARD PRICE	TOTAL
LOGOS (continued)							
	INKFEE	Logo White Ink Setup Fee	White ink setup fee. Required for any logo/branding artwork on the Metal Lectern, Blade Barstool & Chair, Clear Divider collection with a translucent logo.		\$150.00	\$214.29	
	MDFPLG	Madison Desk Logo, Front Panel	Madison Desk		\$418.00	\$597.14	
	CTMTLG	Marble Cocktail Table Top Logo	Alondra and Geo Cocktail Tables		\$340.00	\$485.71	
	CMTWLG	Marble Cocktail Table Top Whiteboard	Alondra and Geo Cocktail Tables		\$353.00	\$504.29	
	ETMTLG	Marble End Table Top Logo	Alondra and Geo ad End Tables		\$150.00	\$214.29	
	EMTWLG	Marble End Table Whiteboard	Alondra and Geo ad End Tables		\$185.00	\$264.29	
	MARLGO	Marche Ottoman Fabric Cover	Slipcover Logo		\$413.00	\$590.00	
	MXFRT	Maxim Bar Logo, Front	Maxim Bar's Front		\$765.00	\$1,092.86	
	MXBCLG	Maxim Bar Logo, Front & Sides	Maxim Bar		\$1,305.00	\$1,864.29	
	MXSIDE	Maxim Bar Logo, Side	Maxim Bar Side		\$230.00	\$328.57	
	MBTLG	Maxim Bar Logo, Top	Maxim Bar's Top		\$435.00	\$621.43	
	MBFWLG	Maxim Bar Whiteboard, Front	Maxim Bar's Front		\$843.00	\$1,204.29	
	MBSWLG	Maxim Bar Whiteboard, Side	Logo		\$265.00	\$378.57	
	MBTWLG	Maxim Bar Whiteboard, Top	Maxim Bar's Top		\$435.00	\$621.43	
	MCFRT	Maxim Counter Logo, Front	Maxim Counter's Front		\$445.00	\$635.71	
	MXCCLG	Maxim Counter Logo, Front & Sides	Maxim Counter		\$908.00	\$1,297.14	
	MCSIDE	Maxim Counter Logo, Side	Maxim Counter's Side		\$230.00	\$328.57	
	MCTLG	Maxim Counter Logo, Top	Maxim Counter's Top		\$208.00	\$297.14	
	MCFWLG	Maxim Counter Whiteboard, Front	Maxim Counter's Front		\$418.00	\$597.14	
	MCTWLG	Maxim Counter Whiteboard, Top	Maxim Counter's Top		\$230.00	\$328.57	
	MLECLG	Metal Lectern Logo	Metal Lectern		\$340.00	\$485.71	
	MTBTLG	Midtown Bar Top Logo (No Cutout)	Midtown Bar		\$455.00	\$650.00	
	MTFLG	Midtown Bar/Counter Front Logo	Midtown Bar and Counter's Front		\$588.00	\$840.00	
	MTBCLG	Midtown Bar/Counter Logo, Front and Sides	Midtown Bar and Counter		\$960.00	\$1,371.43	
	MTSLG	Midtown Bar/Counter Side Logo	Midtown Bar and Counter's Side		\$185.00	\$264.29	
	MTCTLG	Midtown Counter Top Logo (w/ Cutout)	Midtown Counter Top		\$455.00	\$650.00	
	LGOMIR	Miramar Logo	Miramar Divider		\$120.00	\$171.43	
	MLLRLG	Movie Lamp Lens Logo	Movie Lamp		\$135.00	\$192.86	
	PBTTLG	Posh Bar Table Logo, Top	Posh Bar Table		\$170.00	\$242.86	
	PITWLG	Posh Bar Table, Whiteboard	Logo		\$230.00	\$328.57	
	PSH6F	Posh Logo, 6' Front	Front of Posh Bar		\$670.00	\$957.14	
	PSHCLG	Posh Logo, 6' Front and Sides	Posh Bar		\$1,060.00	\$1,514.29	
	PSH6T	Posh Logo, 6' Top	Top of Posh Bar		\$488.00	\$697.14	
	PSHCT	Posh Logo, Corner Pedestal Top	Top of Posh Corner Bar Pedestal		\$220.00	\$314.29	
	PSHS	Posh Logo, Side	Posh Bar or Corner Bar Pedestal Side		\$285.00	\$407.14	
	PBFWLG	Posh Whiteboard, 6' Front	Front of Posh Bar		\$778.00	\$1,111.43	
	PBTWLG	Posh Whiteboard, 6' Top	Top of Posh Bar		\$575.00	\$821.43	
	PCTWLG	Posh Whiteboard, Corner Pedestal Top	Top of Posh Corner Bar Pedestal		\$255.00	\$364.29	
	PCSWLG	Posh Whiteboard, Side	Posh Bar or Corner Bar Pedestal Side		\$333.00	\$475.71	
	PP3BSL	Powered 36" Locking Pedestal Logo, Back & Sides	Powered 36" Locking Pedestal		\$598.00	\$854.29	
	PP3CLG	Powered 36" Locking Pedestal Logo, Front & Sides	Powered 36" Locking Pedestal		\$583.00	\$832.86	
	PP4BSL	Powered 42" Locking Pedestal Logo, Back & Sides	Powered 42" Locking Pedestal		\$693.00	\$990.00	
	PP4CLG	Powered 42" Locking Pedestal Logo, Front & Sides	Powered 42" Locking Pedestal		\$680.00	\$971.43	
	PP3BLG	Powered Locking 36" Pedestal Logo, Back	Powered 36" Locking Pedestal's Back		\$200.00	\$285.71	
	PP3FLG	Powered Locking 36" Pedestal Logo, Front	Powered 36" Locking Pedestal's Front		\$185.00	\$264.29	
	PP3SLG	Powered Locking 36" Pedestal Logo, Side	Powered 36" Locking Pedestal's Side		\$200.00	\$285.71	
	PP4BLG	Powered Locking 42" Pedestal Logo, Back	Powered 42" Locking Pedestal's Back		\$230.00	\$328.57	
	PP4FLG	Powered Locking 42" Pedestal Logo, Front	Powered 42" Locking Pedestal's Front		\$220.00	\$314.29	
	PP4SLG	Powered Locking 42" Pedestal Logo, Side	Powered 42" Locking Pedestal's Side		\$230.00	\$328.57	
	PPTPLG	Powered Locking Pedestal Logo, Top	Powered 42" and 36" Locking Pedestal's Tops		\$170.00	\$242.86	
	LGUSQ	Rustique Square Metal Bar Table Logo	Rustique Square Metal Bar Table		\$170.00	\$242.86	
	SSTTLG	Sedona Side Table Logo	Sedona Side Table		\$118.00	\$168.57	
	SBTTLG	Sonoma 24" Round Logo	Sonoma Round Tables		\$200.00	\$285.71	
	SCTTLG	Sonoma 32" Round Logo	Sonoma Round Tables		\$285.00	\$407.14	
	LGSTN2	Stanchion Logo Sign, Double-Sided	Stanchion Sign Holder Sign Insert		\$123.00	\$175.71	
	LGSTN1	Stanchion Logo Sign, Single-Sided	Stanchion Sign Holder Sign Insert		\$78.00	\$111.43	
	LGSNW2	Stanchion Whiteboard Sign, Double-Sided	Stanchion Sign Holder Sign Insert		\$230.00	\$328.57	
	LGSNW1	Stanchion Whiteboard Sign, Single-Sided	Stanchion Sign Holder Sign Insert		\$133.00	\$190.00	
	C1LGO	Sydney Cocktail Table Logo	Sydney Cocktail Tables		\$298.00	\$425.71	
	SCTWLG	Sydney Cocktail Table Whiteboard	Sydney Cocktail Table		\$405.00	\$578.57	
	E1LGO	Sydney End Table Logo	Sydney End Tables		\$185.00	\$264.29	
	SETWLG	Sydney End Table Whiteboard	Sydney End Table		\$235.00	\$335.71	
	C1PLGO	Sydney Powered Cocktail Table Logo	Sydney Powered Tables		\$340.00	\$485.71	
	TSTTLG	Taos Side Table Logo	Taos Side Table		\$118.00	\$168.57	
	TCHLGO	Tech Chair Tablet Logo	Tech Tablet Chair		\$115.00	\$164.29	
	LG30W	Ventura Grommet Top Logo	Ventura Tables w/ Grommet Holes		\$573.00	\$818.57	
	LG630	Ventura Solid Top Logo	Ventura Tables w/ Solid Top		\$543.00	\$775.71	
	G30WLG	Ventura Solid Top Whiteboard	Ventura Tables w/ Solid Top		\$573.00	\$818.57	
	VNTLGP	Ventura Table Logo, Powered Top	Ventura Powered Tables		\$540.00	\$771.43	
	V1BLGO	Vibe Cube Ottoman Fabric Cover	Slipcover Logo		\$505.00	\$721.43	
	WCTSLG	Wireless Charging Table Logo, Side	Wireless Charging Table's Side		\$133.00	\$190.00	
	WCTTLG	Wireless Charging Table Logo, Top	Wireless Charging Table's Top		\$133.00	\$190.00	
	WCTCLG	Wireless Charging Table Logo, Top & Sides	Wireless Charging Table Complete		\$663.00	\$947.14	
OFFICE & STORAGE ESSENTIALS							
	TECH3	3 Drawer File Cabinet on Castors	Black Top, Black Metal	16" L 20" D 28" H	\$175.00	\$250.00	
	BC8	Madison Bookcase	Gray Acajou	36" L 12" D 72" H	\$563.00	\$804.29	
	JD8	Madison Executive Desk	Gray Acajou, Chrome	60" L 30" D 29" H	\$775.00	\$1,107.14	
OTTOMANS							
	MAR020	Marche Swivel Ottoman	Olive Faux Sheep Fur	17" RND 18" H	\$235.00	\$335.71	
	MAR021	Marche Swivel Ottoman	Terracotta Faux Sheep Fur	17" RND 18" H	\$235.00	\$335.71	
	VIB21	Vibe Cube Ottoman	Caramel Vinyl	18" L 18" D 18" H	\$160.00	\$228.57	
	VIB22	Vibe Cube Ottoman	Navy Vinyl	18" L 18" D 18" H	\$160.00	\$228.57	

QTY	CODE	ITEM	DETAILS	DIMENSIONS	DISCOUNT PRICE	STANDARD PRICE	TOTAL
OTTOMANS (continued)							
	BOHSTR	Boho Stool	Jute, Wood	18.75" RND x 20"H	\$163.00	\$232.86	
	BVLYBK	Beverly Bench Ottoman	Black Vinyl	60"L 20"D 18"H	\$518.00	\$740.00	
	BVLYBN	Beverly Bench Ottoman	Brown Fabric	60"L 20"D 18"H	\$518.00	\$740.00	
	BVLYGR	Beverly Bench Ottoman	Gray Fabric	60"L 20"D 18"H	\$518.00	\$740.00	
	BVLYLN	Beverly Bench Ottoman	Linen Fabric	60"L 20"D 18"H	\$518.00	\$740.00	
	BVLYOB	Beverly Bench Ottoman	Ocean Blue Fabric	60"L 20"D 18"H	\$518.00	\$740.00	
	BVLYRD	Beverly Bench Ottoman	Red Fabric	60"L 20"D 18"H	\$518.00	\$740.00	
	BVLYWH	Beverly Bench Ottoman	White Vinyl	60"L 20"D 18"H	\$518.00	\$740.00	
	BVSMBK	Beverly Small Bench Ottoman	Black Vinyl	30"L 20"D 18"H	\$428.00	\$611.43	
	BVSMBN	Beverly Small Bench Ottoman	Brown Fabric	30"L 20"D 18"H	\$428.00	\$611.43	
	BVSMGY	Beverly Small Bench Ottoman	Gray Fabric	30"L 20"D 18"H	\$428.00	\$611.43	
	BVSMMLV	Beverly Small Bench Ottoman	Lavender Fabric	30"L 20"D 18"H	\$428.00	\$611.43	
	BVSMMLN	Beverly Small Bench Ottoman	Linen Fabric	30"L 20"D 18"H	\$428.00	\$611.43	
	BVSMMLB	Beverly Small Bench Ottoman	Ocean Blue Fabric	30"L 20"D 18"H	\$428.00	\$611.43	
	BVSMGN	Beverly Small Bench Ottoman	Olive Green Fabric	30"L 20"D 18"H	\$428.00	\$611.43	
	BVSMOR	Beverly Small Bench Ottoman	Orange Fabric	30"L 20"D 18"H	\$428.00	\$611.43	
	BVSMRD	Beverly Small Bench Ottoman	Red Fabric	30"L 20"D 18"H	\$428.00	\$611.43	
	BVSMWH	Beverly Small Bench Ottoman	White Vinyl	30"L 20"D 18"H	\$428.00	\$611.43	
	BVSMYL	Beverly Small Bench Ottoman	Yellow Fabric	30"L 20"D 18"H	\$428.00	\$611.43	
	END01B	Endless Curved Ottoman	Black Vinyl, Chrome	60.5"L 37.5"D 15"H	\$675.00	\$964.29	
	END01W	Endless Curved Ottoman	White Vinyl, Chrome	60.5"L 37.5"D 15"H	\$675.00	\$964.29	
	END02B	Endless Square Ottoman	Black Vinyl, Chrome	34"L 34"D 15"H	\$460.00	\$657.14	
	END02W	Endless Square Ottoman	White Vinyl, Chrome	34"L 34"D 15"H	\$460.00	\$657.14	
	MAR015	Marche Swivel Ottoman	Black Vinyl	17"RND 18"H	\$235.00	\$335.71	
	MAR010	Marche Swivel Ottoman	Blue Fabric	17"RND 18"H	\$235.00	\$335.71	
	MAR014	Marche Swivel Ottoman	Distressed Brown Vinyl	17"RND 18"H	\$235.00	\$335.71	
	MAR012	Marche Swivel Ottoman	Forest Green Vinyl	17"RND 18"H	\$235.00	\$335.71	
	MAR002	Marche Swivel Ottoman	Gray Fabric	17"RND 18"H	\$235.00	\$335.71	
	MAR016	Marche Swivel Ottoman	Ivory Faux Sheep Fur	17"L 17"D 18"H	\$235.00	\$335.71	
	MAR003	Marche Swivel Ottoman	Linen Fabric	17"RND 18"H	\$235.00	\$335.71	
	MAR008	Marche Swivel Ottoman	Meadow Green	17"RND 18"H	\$235.00	\$335.71	
	MAR011	Marche Swivel Ottoman	Orange Velvet	17"RND 18"H	\$235.00	\$335.71	
	MAR009	Marche Swivel Ottoman	Pear Yellow Fabric	17"RND 18"H	\$235.00	\$335.71	
	MAR007	Marche Swivel Ottoman	Plum Fabric	17"RND 18"H	\$235.00	\$335.71	
	MAR004	Marche Swivel Ottoman	Raspberry Fabric	17"RND 18"H	\$235.00	\$335.71	
	MAR005	Marche Swivel Ottoman	Red Fabric	17"RND 18"H	\$235.00	\$335.71	
	MAR006	Marche Swivel Ottoman	Rose Quartz Fabric	17"RND 18"H	\$235.00	\$335.71	
	MAR013	Marche Swivel Ottoman	Teal Velvet	17"RND 18"H	\$235.00	\$335.71	
	MAR001	Marche Swivel Ottoman	White Vinyl	17"RND 18"H	\$235.00	\$335.71	
	REGBEN	Regis Bench/Table	Brushed Metal	47"L 15.5"D 16"H	\$433.00	\$618.57	
	VIB10	Vibe Cube Ottoman	Black Vinyl	18"L 18"D 18"H	\$160.00	\$228.57	
	VIB02	Vibe Cube Ottoman	Blue Vinyl	18"L 18"D 18"H	\$160.00	\$228.57	
	VIB05	Vibe Cube Ottoman	Bright Yellow Vinyl	18"L 18"D 18"H	\$160.00	\$228.57	
	VIB14	Vibe Cube Ottoman	Citrus Green Vinyl	18"L 18"D 18"H	\$160.00	\$228.57	
	VIB17	Vibe Cube Ottoman	Desert Rose Vinyl	18"L 18"D 18"H	\$160.00	\$228.57	
	VIB01	Vibe Cube Ottoman	Green Vinyl	18"L 18"D 18"H	\$160.00	\$228.57	
	VIB08	Vibe Cube Ottoman	Orange Vinyl	18"L 18"D 18"H	\$160.00	\$228.57	
	VIB13	Vibe Cube Ottoman	Purple Vinyl	18"L 18"D 18"H	\$160.00	\$228.57	
	VIB04	Vibe Cube Ottoman	Red Vinyl	18"L 18"D 18"H	\$160.00	\$228.57	
	VIB12	Vibe Cube Ottoman	Silver Vinyl	18"L 18"D 18"H	\$160.00	\$228.57	
	VIB16	Vibe Cube Ottoman	Spice Orange Vinyl	18"L 18"D 18"H	\$160.00	\$228.57	
	VIB11	Vibe Cube Ottoman	Steel Blue Vinyl	18"L 18"D 18"H	\$160.00	\$228.57	
	VIB15	Vibe Cube Ottoman	Taupe Vinyl	18"L 18"D 18"H	\$160.00	\$228.57	
	VIB09	Vibe Cube Ottoman	White Vinyl	18"L 18"D 18"H	\$160.00	\$228.57	
	BVLYFA	Beverly Bench Ottoman	Fuchsia Fabric	60"L 20"D 18"H	\$518.00	\$740.00	
	BVLYLV	Beverly Bench Ottoman	Lavender Fabric	60"L 20"D 18"H	\$518.00	\$740.00	
	BVLYLB	Beverly Bench Ottoman	Light Blue Fabric	60"L 20"D 18"H	\$518.00	\$740.00	
	BVLYGN	Beverly Bench Ottoman	Olive Green Fabric	60"L 20"D 18"H	\$518.00	\$740.00	
	BVLYOR	Beverly Bench Ottoman	Orange Fabric	60"L 20"D 18"H	\$518.00	\$740.00	
	BVLYYE	Beverly Bench Ottoman	Yellow Fabric	60"L 20"D 18"H	\$518.00	\$740.00	
	BVSBK	Beverly Seat Back	Black Vinyl	30"L 20"D 28"H	\$428.00	\$611.43	
	BVSBBN	Beverly Seat Back	Brown Fabric	30"L 20"D 28"H	\$428.00	\$611.43	
	BVSBGY	Beverly Seat Back	Gray Fabric	30"L 20"D 28"H	\$428.00	\$611.43	
	BVSBVL	Beverly Seat Back	Lavender Fabric	30"L 20"D 28"H	\$428.00	\$611.43	
	BVSBLN	Beverly Seat Back	Linen Fabric	30"L 20"D 28"H	\$428.00	\$611.43	
	BVSBBL	Beverly Seat Back	Ocean Blue Fabric	30"L 20"D 28"H	\$428.00	\$611.43	
	BVSBGN	Beverly Seat Back	Olive Green Fabric	30"L 20"D 28"H	\$428.00	\$611.43	
	BVSBOR	Beverly Seat Back	Orange Fabric	30"L 20"D 28"H	\$428.00	\$611.43	
	BVSBRD	Beverly Seat Back	Red Fabric	30"L 20"D 28"H	\$428.00	\$611.43	
	BVSBWH	Beverly Seat Back	White Vinyl	30"L 20"D 28"H	\$428.00	\$611.43	
	BVSBYL	Beverly Seat Back	Yellow Fabric	30"L 20"D 28"H	\$428.00	\$611.43	
	BVSBK	Beverly Square Ottoman	Black Vinyl	30"L 30"D 18"H	\$428.00	\$611.43	
	BVSBQN	Beverly Square Ottoman	Brown Fabric	30"L 30"D 18"H	\$428.00	\$611.43	
	BVSBQY	Beverly Square Ottoman	Gray Fabric	30"L 30"D 18"H	\$428.00	\$611.43	
	BVSBQLV	Beverly Square Ottoman	Lavender Fabric	30"L 30"D 18"H	\$428.00	\$611.43	
	BVSBQLN	Beverly Square Ottoman	Linen Fabric	30"L 30"D 18"H	\$428.00	\$611.43	
	BVSBQLB	Beverly Square Ottoman	Ocean Blue Fabric	30"L 30"D 18"H	\$428.00	\$611.43	
	BVSBQGN	Beverly Square Ottoman	Olive Green Fabric	30"L 30"D 18"H	\$428.00	\$611.43	
	BVSBQOR	Beverly Square Ottoman	Orange Fabric	30"L 30"D 18"H	\$428.00	\$611.43	
	BVSBQRD	Beverly Square Ottoman	Red Fabric	30"L 30"D 18"H	\$428.00	\$611.43	
	BVSBQWH	Beverly Square Ottoman	White Vinyl	30"L 30"D 18"H	\$428.00	\$611.43	
	BVSBQYL	Beverly Square Ottoman	Yellow Fabric	30"L 30"D 18"H	\$428.00	\$611.43	
	END0TB	Endless Closed Circle Ottoman	Black, 8 seats	158"RND 15"H	\$5,655.00	\$8,078.57	
	ELCCEC	Endless Closed Circle Ottoman	Emerald Velvet Channel Stitch, Black Frame, 8 seats	158"RND 15"H	\$5,655.00	\$8,078.57	

QTY	CODE	ITEM	DETAILS	DIMENSIONS	DISCOUNT PRICE	STANDARD PRICE	TOTAL
OTTOMANS (continued)							
	ELCCWC	Endless Closed Circle Ottoman	White Vinyl Channel Stitch, Black Frame, 8 seats	158" RND 15"H	\$5,655.00	\$8,078.57	
	ENDOTW	Endless Closed Circle Ottoman	White, 8 seats	158" RND 15"H	\$5,670.00	\$8,100.00	
	EDCOEC	Endless Curved Ottoman	Emerald Velvet Channel Stitch, Black Frame	60.5"L 37.5"D 15"H	\$715.00	\$1,021.43	
	EDCOWC	Endless Curved Ottoman	White Vinyl Channel Stitch, Black Frame	60.5"L 37.5"D 15"H	\$715.00	\$1,021.43	
	ESD01B	Endless Dining Curved Ottoman	Black	60.5"L 37.5"D 18"H	\$710.00	\$1,014.29	
	ESD01W	Endless Dining Curved Ottoman	White	60.5"L 37.5"D 18"H	\$710.00	\$1,014.29	
	ESD02B	Endless Dining Square Ottoman	Black	34"L 34"D 18"H	\$558.00	\$797.14	
	ESD02W	Endless Dining Square Ottoman	White	34"L 34"D 18"H	\$558.00	\$797.14	
	EHROEC	Endless Half Round Ottoman	Emerald Velvet Channel Stitch, Black Frame	34.5"L 34.5"D 15"H	\$700.00	\$1,000.00	
	EHROWC	Endless Half Round Ottoman	White Vinyl Channel Stitch, Black Frame	34.5"L 34.5"D 15"H	\$700.00	\$1,000.00	
	EHROWH	Endless Half Round Ottoman	White Vinyl, Chrome Frame	34.5"L 34.5"D 15"H	\$700.00	\$1,000.00	
	E200EC	Endless Oval Ottoman	Emerald Velvet Channel, Black Frame, 2 Half Round Ottomans	69"L 34.5"D 15"H	\$1,378.00	\$1,968.57	
	E200WC	Endless Oval Ottoman	White Vinyl Channel, Black Frame, 2 Half Round Ottomans	69"L 34.5"D 15"H	\$1,378.00	\$1,968.57	
	ESQOEC	Endless Square Ottoman	Emerald Velvet Channel Stitch, Black Frame	34.5"L 34.5"D 15"H	\$460.00	\$657.14	
	ESQOWC	Endless Square Ottoman	White Vinyl Channel Stitch, Black Frame	34.5"L 34.5"D 15"H	\$460.00	\$657.14	
	MAR017	Marche Boho Ottoman	Belize Fabric	18" RND 18"H	\$328.00	\$468.57	
	MAR018	Marche Boho Ottoman	Durango Fabric	18" RND 18"H	\$328.00	\$468.57	
	MAR019	Marche Boho Ottoman	Merida Fabric	18" RND 18"H	\$328.00	\$468.57	
	RBENCH	Rustique Bench	Wood	55"L 13.5"D 17.5"H	\$270.00	\$385.71	
	VIB18	Vibe Boho Ottoman	Hidalgo Fabric	19"L 19"D 18"H	\$328.00	\$468.57	
	VIB19	Vibe Boho Ottoman	Leon Fabric	19"L 19"D 18"H	\$328.00	\$468.57	
	VIB20	Vibe Boho Ottoman	Tulum Fabric	19"L 19"D 18"H	\$328.00	\$468.57	
PEDESTALS							
	PP20AC	Posh Pedestal, 20"	LED Lighted w/ AC Plug	18"L 18"W 20"H	\$563.00	\$804.29	
	PP20DC	Posh Pedestal, 20"	LED Lighted w/ DC	18"L 18"W 20"H	\$563.00	\$804.29	
	PP20UL	Posh Pedestal, 20"	Unlit	18"L 18"W 20"H	\$400.00	\$571.43	
	PP40AC	Posh Pedestal, 42"	LED Lighted w/ AC Plug	18"L 18"W 40"H	\$773.00	\$1,104.29	
	PP40DC	Posh Pedestal, 42"	LED Lighted w/ DC	18"L 18"W 40"H	\$773.00	\$1,104.29	
	PP40UL	Posh Pedestal, 42"	Unlit	18"L 18"W 40"H	\$505.00	\$721.43	
POWERED PRODUCT							
	BKC10P	10' Table, Powered	Black Top, Silver	120"L 48"D 29"H	\$2,363.00	\$3,375.71	
	P30BWH	30" Round Bar Table, Powered	White Top, Black	30" RND 42"H	\$910.00	\$1,300.00	
	P30CWH	30" Round Cafe Table, Powered	White Top, Black	30" RND 29"H	\$910.00	\$1,300.00	
	ADCTBP	Adelaide Powered Cocktail Table	Black Top, Silver	48.875"L 25.375"D 18"H	\$578.00	\$825.71	
	ADCTWP	Adelaide Powered Cocktail Table	White Top, Silver	48.875"L 25.375"D 18"H	\$578.00	\$825.71	
	NPLCHP	Naples Chair, Powered	Black Vinyl	36"L 30"D 33.25"H	\$1,103.00	\$1,575.71	
	NPLLOP	Naples Loveseat, Powered	Black Vinyl	62"L 30"D 33.25"H	\$1,478.00	\$2,111.43	
	NPLSOP	Naples Sofa, Powered	Black Vinyl	87"L 30"D 33.25"H	\$1,703.00	\$2,432.86	
	CIYP	Sydney Powered Cocktail Table	Black Top, Brushed Steel	48"L 26"D 18"H	\$463.00	\$661.43	
	CIWP	Sydney Powered Cocktail Table	White Top, Brushed Steel	48"L 26"D 18"H	\$460.00	\$657.14	
	TCHP	Tech Chair, No Tablet	Gray Vinyl, Chrome Base	30.5"L 29"D 33.5"H	\$613.00	\$875.71	
	TECH	Tech Desk, Powered	Black Metal, Black Laminate w/electrical unit	60"L 30"D 30"H	\$578.00	\$825.71	
	TECH3B	Tech Desk, Powered w/ 3 Drawer File Cabinet	Black Metal, Black Laminate w/electrical unit	60"L 30"D 30"H	\$715.00	\$1,021.43	
	TCHGRY	Tech Tablet Chair	Gray Vinyl, White Metal Tablet, Chrome Base	30.5"L 29"D 33.5"H	\$595.00	\$850.00	
	VNTBLK	Ventura Communal Bar Table, Powered	Black Top, Silver	72.25"L 26.25"D 42"H	\$1,438.00	\$2,054.29	
	VNTWHT	Ventura Communal Bar Table, Powered	White Top, Silver	72.25"L 26.25"D 42"H	\$1,438.00	\$2,054.29	
	VNTCBK	Ventura Communal Cafe Table, Powered	Black Top, Silver	72.25"L 26.25"D 30"H	\$1,158.00	\$1,654.29	
	VNTCWH	Ventura Communal Cafe Table, Powered	White Top, Silver	72.25"L 26.25"D 30"H	\$1,158.00	\$1,654.29	
	VILHUB	Village Charging Hub	Cream	12"L 12"D 28.25"H	\$388.00	\$554.29	
	CUBPOW	Wireless Charging Table, Powered	White, AC Plug In	20"L 20"D 18"H	\$610.00	\$871.43	
	C10PWR	10' Table, Powered	White Top, Silver	120"L 48"D 29"H	\$1,715.00	\$2,450.00	
	C5PWR	5' Table, Powered	White Top, Silver	60"L 48"D 29"H	\$888.00	\$1,268.57	
	C8PWR	8' Table, Powered	White Top, Silver	96"L 60"D 29"H	\$1,715.00	\$2,450.00	
	ELC3PB	Endless Powered 3-Seat Curved Ottoman w/ Large Curved Tables	Black, White/Chrome	146"L 66"D 15"H	\$2,858.00	\$4,082.86	
	ELC3PW	Endless Powered 3-Seat Curved Ottoman w/ Large Curved Tables	White, White/Chrome	146"L 66"D 15"H	\$2,858.00	\$4,082.86	
	ESC3PB	Endless Powered 3-Seat Curved Ottoman w/ Small Curved Tables	Black, White/Chrome	146"L 66"D 15"H	\$2,858.00	\$4,082.86	
	ESC3PW	Endless Powered 3-Seat Curved Ottoman w/ Small Curved Tables	White, White/Chrome	146"L 66"D 15"H	\$2,858.00	\$4,082.86	
	ESP6B	Endless Powered 6-Seat Square Ottoman/Table	Black, White/Chrome	102"L 70"D 15"H	\$5,010.00	\$7,157.14	
	ESP6W	Endless Powered 6-Seat Square Ottoman/Table	White, White/Chrome	102"L 70"D 15"H	\$5,010.00	\$7,157.14	
	ESC8PB	Endless Powered Closed Circle Ottoman w/ Small Curved Tables	Black, White/Chrome, 8 Seats	161"L 161"D 15"H	\$7,928.00	\$11,325.71	
	ESC8PW	Endless Powered Closed Circle Ottoman w/ Small Curved Tables	White, White/Chrome, 8 Seats	161"L 161"D 15"H	\$7,928.00	\$11,325.71	
	ELB6TB	Endless Powered Double Square Low Back Sofa w/4 Round Tables	Black, Glass/Chrome	102"L 101"D 27"H	\$7,255.00	\$10,364.29	
	ELB6TW	Endless Powered Double Square Low Back Sofa w/4 Round Tables	White, Glass/Chrome	102"L 101"D 27"H	\$7,255.00	\$10,364.29	
	ECH8TW	Endless Powered High Back Closed Circle w/8 Round Tables	White, Glass/Chrome, 8 Seats	190"L 190"D 47"H	\$9,935.00	\$14,192.86	
	ELC3TB	Endless Powered Large Curve Low Back Sofa w/2 Round Tables	Black, Glass/Chrome	146"L 79"D 27"H	\$3,170.00	\$4,528.57	
	ELC3TW	Endless Powered Large Curve Low Back Sofa w/2 Round Tables	White, Glass/Chrome	146"L 79"D 27"H	\$3,170.00	\$4,528.57	
	ELC1PB	Endless Powered Large Curved Table w/Curved Ottoman	Black, White/Chrome	60.5"L 40"D 15"H	\$953.00	\$1,361.43	
	ELC1PW	Endless Powered Large Curved Table w/Curved Ottoman	White, White/Chrome	63"L 40"D 15"H	\$953.00	\$1,361.43	
	ECL8TB	Endless Powered Low Back Closed Circle w/8 Round Tables	Black, Glass/Chrome, 8 Seats	190"L 190"D 27"H	\$9,110.00	\$13,014.29	
	ECL8TW	Endless Powered Low Back Closed Circle w/8 Round Tables	White, Glass/Chrome, 8 Seats	190"L 190"D 27"H	\$9,110.00	\$13,014.29	
	EPLCME	Endless Powered Low Back Comma Sectional w/ 2 Round Tables	Emerald Velvet Channel Stitch, Black Frame, 2 Curve Chairs and 2 Half Round Ottomans with 2 Marble/Chrome Tables	138"L 70"D 27"H	\$4,630.00	\$6,614.29	
	EPLCGE	Endless Powered Low Back Comma Sectional w/ 2 Round Tables	Emerald Velvet Channel Stitch, Black Frame, 2 Curve Chairs and 2 Half Round Ottomans with 2 Glass/Chrome Tables	138"L 70"D 27"H	\$4,630.00	\$6,614.29	

QTY	CODE	ITEM	DETAILS	DIMENSIONS	DISCOUNT PRICE	STANDARD PRICE	TOTAL
POWERED PRODUCT (continued)							
	EPLCGW	Endless Powered Low Back Comma Sectional w/ 2 Round Tables	White Vinyl Channel Stitch, Black Frame, 2 Curve Chairs and 2 Half Round Ottomans with 2 Glass/Chrome Tables	138"L 70"D 27"H	\$4,630.00	\$6,614.29	
	EPLCMW	Endless Powered Low Back Comma Sectional w/ 2 Round Tables	White Vinyl Channel Stitch, Black Frame, 2 Curve Chairs and 2 Half Round Ottomans with 2 Marble/Chrome Tables	138"L 70"D 27"H	\$4,630.00	\$6,614.29	
	EPLSGE	Endless Powered Low Back S Curve Sectional w/ 4 Round Tables	Emerald Velvet Channel Stitch, Black Frame, 6 Curve Chairs and 2 Half Round Ottomans and 4 Glass/Chrome Tables	277"L 103"D 27"H	\$9,975.00	\$14,250.00	
	EPLSGW	Endless Powered Low Back S Curve Sectional w/ 4 Round Tables	White Vinyl Channel Stitch, Black Frame, 6 Curve Chairs and 2 Half Round Ottomans with 4 Glass/Chrome Tables	277"L 103"D 27"H	\$9,975.00	\$14,250.00	
	ESIPB	Endless Powered Rectangle Table w/Square Ottoman	Black, White/Chrome	34"L 36"D 15"H	\$833.00	\$1,190.00	
	ESIPW	Endless Powered Rectangle Table w/Square Ottoman	White, White/Chrome	34"L 36"D 15"H	\$833.00	\$1,190.00	
	ESFTGP	Endless Powered Round Table	Glass, Chrome	16"RND 21"H	\$415.00	\$592.86	
	ESFTMP	Endless Powered Round Table	Marble, Chrome	16"RND 21"H	\$415.00	\$592.86	
	EC6TGB	Endless Powered Serpentine w/6 Round Tables	Black, Glass/Chrome, 6 Seats	246"L 120"D 15"H	\$6,123.00	\$8,747.14	
	EC6TGW	Endless Powered Serpentine w/6 Round Tables	White, Glass/Chrome, 6 Seats	246"L 120"D 15"H	\$6,123.00	\$8,747.14	
	ECL3TB	Endless Powered Small Curve Low Back Sofa w/2 Round Tables	Black, Glass/Chrome	146"L 79"D 27"H	\$2,988.00	\$4,268.57	
	ECL3TW	Endless Powered Small Curve Low Back Sofa w/2 Round Tables	White, Glass/Chrome	146"L 79"D 27"H	\$2,988.00	\$4,268.57	
	ESCIPB	Endless Powered Small Curved Table w/Curved Ottoman	Black, White/Chrome	61"L 40"D 15"H	\$953.00	\$1,361.43	
	ESCIPW	Endless Powered Small Curved Table w/Curved Ottoman	White, White/Chrome	61"L 40"D 15"H	\$953.00	\$1,361.43	
	LEXBAR	Lexington Powered Communal Bar Table	Wood, Metal	65"L 36"D 42"H	\$1,453.00	\$2,075.71	
	LEXCAF	Lexington Powered Communal Cafe Table	Wood, Metal	65"L 36"D 30"H	\$1,255.00	\$1,792.86	
	MIOPWR	Madison 10' Table, Powered	Gray Acajou, Silver	120"L 48"D 29"H	\$1,715.00	\$2,450.00	
	MSPWR	Madison 5' Table, Powered	Gray Acajou, Silver	60"L 48"D 29"H	\$888.00	\$1,268.57	
	M8PWR	Madison 8' Table, Powered	Gray Acajou, Silver	96"L 60"D 29"H	\$1,715.00	\$2,450.00	
PRODUCT DISPLAY							
	PDL36B	Powered Locking Pedestal, 36"	Black	24"L 24"D 36"H	\$610.00	\$871.43	
	PDL36W	Powered Locking Pedestal, 36"	White	24"L 24"D 36"H	\$610.00	\$871.43	
	PDL42B	Powered Locking Pedestal, 42"	Black	24"L 24"D 42"H	\$728.00	\$1,040.00	
	PDL42W	Powered Locking Pedestal, 42"	White	24"L 24"D 42"H	\$728.00	\$1,040.00	
	STNSGN	Stanchion Sign Holder	Chrome	10"L 13"H	\$241.00	\$344.29	
	STNCHI	Stanchion w/ Retractable Belt	Black, Chrome	96"L 37"H	\$253.00	\$361.43	
	GEOSHF	Geometric Shelving	Bronze Metal/Wood	30"L 16"D 85"H	\$678.00	\$968.57	
	MTLCAC	Metal Lectern, LED AC Plug-In	Gray Metal, Lit AC	23.5"L 19.3"D 47"H	\$675.00	\$964.29	
	METLEC	Metal Lectern, LED DC Battery	Gray Metal, Lit DC	23.5"L 19.3"D 47"H	\$675.00	\$964.29	
SHELVING							
	PSHCCS	Posh Shelving	Chrome, Acrylic	36"L 18"D 72"H	\$660.00	\$942.86	
SOFT SEATING							
	VALCGN	Valencia Chair	Green Fabric	28"L 30.5"D 31"H	\$493.00	\$704.29	
	VALCOT	Valencia Chair	Oat Fabric	28"L 30.5"D 31"H	\$493.00	\$704.29	
	VALVOT	Valencia Loveseat	Oat Fabric	63"L 30.5"D 31"H	\$625.00	\$892.86	
	CACHGN	Cabo Chair	Fern Green Fabric, Teak Base	31.5"L 34.5"D 33"H	\$1,065.00	\$1,521.43	
	CASFGN	Cabo Sofa	Fern Green Fabric, Teak Base	80"L 34.5"D 33"H	\$1,375.00	\$1,964.29	
	SFA002	Allegro Sofa	Blue Fabric, Brushed Metal	73"L 34.5"D 30"H	\$895.00	\$1,278.57	
	BLVWHT	Baja Loveseat	White Vinyl	61"L 30.5"D 28"H	\$1,023.00	\$1,461.43	
	BSFWHT	Baja Sofa	White Vinyl	86"L 30"D 28"H	\$1,193.00	\$1,704.29	
	COCHTP	Cordoba Chair	Taupe Fabric, Black	37"L 32"D 33"H	\$705.00	\$1,007.14	
	COLVTP	Cordoba Loveseat	Taupe Fabric, Black	60.5"L 32"D 33"H	\$1,008.00	\$1,440.00	
	FAIRSW	Fairfax Loveseat	White Vinyl, Brushed Metal	62"L 26"D 30"H	\$610.00	\$871.43	
	KEYLOV	Key Largo Loveseat	Black Fabric, Wood	57"L 35"D 34"H	\$465.00	\$664.29	
	KEYSOF	Key Largo Sofa	Black Fabric, Wood	79"L 35"D 34"H	\$588.00	\$840.00	
	NPLLOV	Naples Loveseat	Black Vinyl	62"L 30"D 33.25"H	\$905.00	\$1,292.86	
	NPLSOF	Naples Sofa	Black Vinyl	87"L 30"D 33.25"H	\$1,073.00	\$1,532.86	
	PALSOF	Palm Beach Sofa	White Vinyl, Chrome	69"L 29"D 33"H	\$938.00	\$1,340.00	
	STESOF	Sterling Sofa	Gray Fabric	82"L 33.5"D 32"H	\$1,613.00	\$2,304.29	
	VALSOF	Valencia Loveseat	Coffee Brown Velvet	63"L 30.5"D 31"H	\$625.00	\$892.86	
	MONLOV	Montreal Loveseat	Blue, Black Metal	62"L 27.25"D 29.5"H	\$1,345.00	\$1,921.43	
	ASCHBK	Aspen Chair	Black Vinyl	27.5"L 30.5"D 31.25"H	\$673.00	\$961.43	
	ASCHPB	Aspen Chair	Pebble Fabric	27.5"L 30.5"D 31.25"H	\$673.00	\$961.43	
	ASLVBK	Aspen Loveseat	Black Vinyl	50"L 30.5"D 31.25"H	\$1,200.00	\$1,714.29	
	BLBKPC	Beverly Oasis Large Grouping	Black Vinyl	139"L 80"D 28"H	\$5,748.00	\$8,211.43	
	BLBRPC	Beverly Oasis Large Grouping	Brown Fabric	139"L 80"D 28"H	\$5,748.00	\$8,211.43	
	BLGYPC	Beverly Oasis Large Grouping	Gray Fabric	139"L 80"D 28"H	\$5,748.00	\$8,211.43	
	BLVPAC	Beverly Oasis Large Grouping	Lavender Fabric	139"L 80"D 28"H	\$5,748.00	\$8,211.43	
	BLLPAC	Beverly Oasis Large Grouping	Linen Fabric	139"L 80"D 28"H	\$5,748.00	\$8,211.43	
	BLAPAC	Beverly Oasis Large Grouping	Ocean Blue Fabric	139"L 80"D 28"H	\$5,748.00	\$8,211.43	
	BLGNPC	Beverly Oasis Large Grouping	Olive Green Fabric	139"L 80"D 28"H	\$5,748.00	\$8,211.43	
	BLORPC	Beverly Oasis Large Grouping	Orange Fabric	139"L 80"D 28"H	\$5,748.00	\$8,211.43	
	BLRPAC	Beverly Oasis Large Grouping	Red Fabric	139"L 80"D 28"H	\$5,748.00	\$8,211.43	
	BLWPAC	Beverly Oasis Large Grouping	White Vinyl	139"L 80"D 28"H	\$5,748.00	\$8,211.43	
	BLYPAC	Beverly Oasis Large Grouping	Yellow Fabric	139"L 80"D 28"H	\$5,748.00	\$8,211.43	
	BMBKPC	Beverly Oasis Medium Grouping	Black Vinyl	100"L 80"D 28"H	\$3,850.00	\$5,500.00	
	BMBRPC	Beverly Oasis Medium Grouping	Brown Fabric	100"L 80"D 28"H	\$3,850.00	\$5,500.00	
	BMGYPC	Beverly Oasis Medium Grouping	Gray Fabric	100"L 80"D 28"H	\$3,850.00	\$5,500.00	
	BMVPAC	Beverly Oasis Medium Grouping	Lavender Fabric	100"L 80"D 28"H	\$3,850.00	\$5,500.00	
	BMLPAC	Beverly Oasis Medium Grouping	Linen Fabric	100"L 80"D 28"H	\$3,850.00	\$5,500.00	
	BMAPAC	Beverly Oasis Medium Grouping	Ocean Blue Fabric	100"L 80"D 28"H	\$3,850.00	\$5,500.00	
	BMGNPC	Beverly Oasis Medium Grouping	Olive Green Fabric	100"L 80"D 28"H	\$3,850.00	\$5,500.00	
	BMORPC	Beverly Oasis Medium Grouping	Orange Fabric	100"L 80"D 28"H	\$3,850.00	\$5,500.00	
	BMRPAC	Beverly Oasis Medium Grouping	Red Fabric	100"L 80"D 28"H	\$3,850.00	\$5,500.00	
	BMWPAC	Beverly Oasis Medium Grouping	White Vinyl	100"L 80"D 28"H	\$3,850.00	\$5,500.00	
	BMYPAC	Beverly Oasis Medium Grouping	Yellow Fabric	100"L 80"D 28"H	\$3,850.00	\$5,500.00	
	BSBKPC	Beverly Oasis Small Grouping	Black Vinyl	80"L 70"D 28"H	\$2,740.00	\$3,914.29	
	BSBRPC	Beverly Oasis Small Grouping	Brown Fabric	80"L 70"D 28"H	\$2,740.00	\$3,914.29	

QTY	CODE	ITEM	DETAILS	DIMENSIONS	DISCOUNT PRICE	STANDARD PRICE	TOTAL
SOFT SEATING (continued)							
	BSGYPC	Beverly Oasis Small Grouping	Gray Fabric	80"L 70"D 28"H	\$2,740.00	\$3,914.29	
	BSVPAC	Beverly Oasis Small Grouping	Lavender Fabric	80"L 70"D 28"H	\$2,740.00	\$3,914.29	
	BSLPAC	Beverly Oasis Small Grouping	Linen Fabric	80"L 70"D 28"H	\$2,740.00	\$3,914.29	
	BSAPAC	Beverly Oasis Small Grouping	Ocean Blue Fabric	80"L 70"D 28"H	\$2,740.00	\$3,914.29	
	BSGPAC	Beverly Oasis Small Grouping	Olive Green Fabric	80"L 70"D 28"H	\$2,740.00	\$3,914.29	
	BSOPAC	Beverly Oasis Small Grouping	Orange Fabric	80"L 70"D 28"H	\$2,740.00	\$3,914.29	
	BSRPAC	Beverly Oasis Small Grouping	Red Fabric	80"L 70"D 28"H	\$2,740.00	\$3,914.29	
	BSWPAC	Beverly Oasis Small Grouping	White Vinyl	80"L 70"D 28"H	\$2,740.00	\$3,914.29	
	BSYPAC	Beverly Oasis Small Grouping	Yellow Fabric	80"L 70"D 28"H	\$2,740.00	\$3,914.29	
	BOCLOV	Boca Loveseat	Brown, Tan Cushions	66"L 33"D 25.5"H	\$1,030.00	\$1,471.43	
	BOCSEC	Boca Sectional	Brown, Tan Cushions	94"L 94"D 25.5"H	\$2,375.00	\$3,392.86	
	BOCSOF	Boca Sofa	Brown, Tan Cushions	94"L 33"D 25.5"H	\$1,493.00	\$2,132.86	
	BRACSD	Brighton Armless Chair	Sand Fabric	32.5"L 32.5"D 29.75"H	\$428.00	\$611.43	
	BRACWH	Brighton Armless Chair	White Vinyl	32.5"L 32.5"D 29.75"H	\$428.00	\$611.43	
	BRCCSD	Brighton Corner Chair	Sand Fabric	32.5"L 32.5"D 29.75"H	\$428.00	\$611.43	
	BRCCWH	Brighton Corner Chair	White Vinyl	32.5"L 32.5"D 29.75"H	\$428.00	\$611.43	
	BRLVSD	Brighton Loveseat	Sand Fabric	66"L 32.5"D 29.75"H	\$1,148.00	\$1,640.00	
	BRLVWH	Brighton Loveseat	White Vinyl	66"L 32.5"D 29.75"H	\$1,148.00	\$1,640.00	
	BRSCSD	Brighton Sectional	Sand Fabric	98.5"L 65"D 29.75"H	\$2,370.00	\$3,385.71	
	BRSCWH	Brighton Sectional	White Vinyl	98.5"L 65"D 29.75"H	\$2,370.00	\$3,385.71	
	BRSFSD	Brighton Sofa	Sand Fabric	97.5"L 32.5"D 29.75"H	\$1,835.00	\$2,621.43	
	BRSFWH	Brighton Sofa	White Vinyl	97.5"L 32.5"D 29.75"H	\$1,835.00	\$2,621.43	
	CHASOF	Chandler Sofa	Cranberry Fabric	85"L 34.5"D 31"H	\$1,615.00	\$2,307.14	
	CONSOF	Constellation Sofa	Tufted White Vinyl	87.5"L 40.5"D 30"H	\$1,680.00	\$2,400.00	
	ESDSIB	Endless Dining Low Back Sectional w/ Arms	Black	103"L 103"D 30"H	\$3,560.00	\$5,085.71	
	ESDSIW	Endless Dining Low Back Sectional w/ Arms	White	103"L 103"D 30"H	\$3,560.00	\$5,085.71	
	ENDHBW	Endless High Back Closed Circle	White, 8 Seats	158"RND 47"H	\$7,683.00	\$10,975.71	
	END04W	Endless High Back Serpentine	White, 6 Seats	246"L 88"D 47"H	\$5,065.00	\$7,235.71	
	END27W	Endless Large Curve High Back Circle	White, 6 Seats	158"RND 47"H	\$4,445.00	\$6,350.00	
	END22W	Endless Large Curve High Back Loveseat	White, 2 Seats	112"L 48"D 47"H	\$2,023.00	\$2,890.00	
	END23W	Endless Large Curve High Back Sofa	White, 3 Seats	146"L 63"D 47"H	\$2,620.00	\$3,742.86	
	END26B	Endless Large Curve Low Back Circle	Black, 6 Seats	158"RND 27"H	\$4,018.00	\$5,740.00	
	END26W	Endless Large Curve Low Back Circle	White, 6 Seats	158"RND 27"H	\$4,018.00	\$5,740.00	
	END19B	Endless Large Curve Low Back Loveseat	Black, 2 Seats	112"L 48"D 27"H	\$1,780.00	\$2,542.86	
	ECLLEC	Endless Large Curve Low Back Loveseat	Emerald Velvet Channel Stitch, Black Frame, 2 Seats	112"L 48"D 27"H	\$1,780.00	\$2,542.86	
	ECLLWC	Endless Large Curve Low Back Loveseat	White Vinyl Channel Stitch, Black Frame, 2 Seats	112"L 48"D 27"H	\$1,780.00	\$2,542.86	
	END19W	Endless Large Curve Low Back Loveseat	White, 2 Seats	112"L 48"D 27"H	\$1,780.00	\$2,542.86	
	END20B	Endless Large Curve Low Back Sofa	Black, 3 Seats	146"L 63"D 27"H	\$2,310.00	\$3,300.00	
	ECLSEC	Endless Large Curve Low Back Sofa	Emerald Velvet Channel Stitch, Black Frame, 3 Seats	146"L 63"D 27"H	\$2,310.00	\$3,300.00	
	ECLSWC	Endless Large Curve Low Back Sofa	White Vinyl Channel Stitch, Black Frame, 3 Seats	146"L 63"D 27"H	\$2,310.00	\$3,300.00	
	END20W	Endless Large Curve Low Back Sofa	White, 3 Seats	146"L 63"D 27"H	\$2,310.00	\$3,300.00	
	ENDLBB	Endless Low Back Closed Circle	Black, 8 seats	158"RND 27"H	\$6,250.00	\$8,928.57	
	ENDLBW	Endless Low Back Closed Circle	White, 8 seats	158"RND 27"H	\$6,250.00	\$8,928.57	
	ELCSEC	Endless Low Back Comma Sectional	Emerald Velvet Channel Stitch, Black Frame, 2 Curve Chairs and 2 Half Round Ottomans	138"L 70"D 27"H	\$3,713.00	\$5,304.29	
	ELCSWC	Endless Low Back Comma Sectional	White Vinyl Channel Stitch, Black Frame, 2 Curve Chairs and 2 Half Round Ottomans	138"L 70"D 27"H	\$3,713.00	\$5,304.29	
	ENDC5B	Endless Low Back Loveseat w/ Arms	Black	69"L 34.5"D 27"H	\$1,493.00	\$2,132.86	
	ENDC5W	Endless Low Back Loveseat w/ Arms	White	69"L 34.5"D 27"H	\$1,493.00	\$2,132.86	
	ELSSEC	Endless Low Back S Curve Sectional	Emerald Vinyl Channel Stitch, Black Frame, 6 Curve Chairs and 2 Half Round Ottomans	277"L 103"D 27"H	\$8,133.00	\$11,618.57	
	ELSCWC	Endless Low Back S Curve Sectional	White Vinyl Channel Stitch, Black Frame, 6 Curve Chairs and 2 Half Round Ottomans	277"L 103"D 27"H	\$8,133.00	\$11,618.57	
	END28B	Endless Low Back Sectional	Black, 4 Square Seats, 1 Large Curve Seat	189"L 65"D 27"H	\$3,378.00	\$4,825.71	
	END28W	Endless Low Back Sectional	White, 4 Square Seats, 1 Large Curve Seat	189"L 65"D 27"H	\$3,378.00	\$4,825.71	
	ENDC1B	Endless Low Back Sectional w/ Arms	Black	103"L 103"D 27"H	\$3,560.00	\$5,085.71	
	ENDC1W	Endless Low Back Sectional w/ Arms	White	103"L 103"D 27"H	\$3,560.00	\$5,085.71	
	END04B	Endless Low Back Serpentine	Black, 6 Seats	246"L 88"D 27"H	\$4,445.00	\$6,350.00	
	END05W	Endless Low Back Serpentine	White, 6 Seats	246"L 88"D 27"H	\$4,445.00	\$6,350.00	
	ENDC3B	Endless Low Back Sofa w/ Arms	Black	103"L 34.5"D 27"H	\$1,955.00	\$2,792.86	
	ENDC3W	Endless Low Back Sofa w/ Arms	White	103"L 34.5"D 27"H	\$1,955.00	\$2,792.86	
	END05B	Endless Serpentine	Black, 6 Seats	246"L 88"D 15"H	\$2,910.00	\$4,157.14	
	END03W	Endless Serpentine	White, 6 Seats	246"L 88"D 15"H	\$2,910.00	\$4,157.14	
	END13B	Endless Small Curve Low Back Loveseat	Black, 2 Seats	112"L 48"D 27"H	\$1,780.00	\$2,542.86	
	END13W	Endless Small Curve Low Back Loveseat	White, 2 Seats	112"L 48"D 27"H	\$1,780.00	\$2,542.86	
	END14B	Endless Small Curve Low Back Sofa	Black, 3 Seats	146"L 63"D 27"H	\$2,310.00	\$3,300.00	
	END14W	Endless Small Curve Low Back Sofa	White, 3 Seats	146"L 63"D 27"H	\$2,310.00	\$3,300.00	
	END07B	Endless Square Low Back Loveseat	Black	68"L 34.5"D 27"H	\$1,425.00	\$2,035.71	
	ESLLEC	Endless Square Low Back Loveseat	Emerald Velvet Channel Stitch, Black Frame, 2 Seats	69"L 34.5"D 27"H	\$1,425.00	\$2,035.71	
	END07W	Endless Square Low Back Loveseat	White	68"L 34.5"D 27"H	\$1,425.00	\$2,035.71	
	ESLLWC	Endless Square Low Back Loveseat	White Vinyl Channel Stitch, Black Frame, 2 Seats	69"L 34.5"D 27"H	\$1,425.00	\$2,035.71	
	END08B	Endless Square Low Back Sofa	Black	102"L 34.5"D 27"H	\$1,955.00	\$2,792.86	
	ESLSEC	Endless Square Low Back Sofa	Emerald Velvet Channel Stitch, Black Frame, 3 Seats	103.5"L 34.5"D 27"H	\$1,955.00	\$2,792.86	
	END08W	Endless Square Low Back Sofa	White	102"L 34.5"D 27"H	\$1,955.00	\$2,792.86	
	ESLWC	Endless Square Low Back Sofa	White Vinyl Channel Stitch, Black Frame, 3 Seats	103.5"L 34.5"D 27"H	\$1,955.00	\$2,792.86	
	MNROCH	Monroe Chair	Mink Velvet	33.5"L 31.5"D 27.5"H	\$673.00	\$961.43	
	MNROLV	Monroe Loveseat	Mink Velvet	62"L 31.5"D 27.5"H	\$1,200.00	\$1,714.29	
	MNCHLV	Munich Armless Loveseat	Gray Fabric, Black	45"L 27"D 28.5"H	\$1,148.00	\$1,640.00	
	MNCHLA	Munich Loveseat w/ Arms	Gray Fabric, Black	54"L 27"D 28.5"H	\$1,200.00	\$1,714.29	
	MNCHSC	Munich Sectional, 3 Pc.	Gray Fabric, Black	93.5"L 27"D 28.5"H	\$2,370.00	\$3,385.71	
	MNCHSA	Munich Sofa w/ Arms	Gray Fabric, Black	74.5"L 27"D 28.5"H	\$1,835.00	\$2,621.43	
TABLES							
	DORATB	Dorado Accent Table	Antique Brass	15" RND 18"H	\$283.00	\$404.29	
	MUISTB	Muir Side Table	Black Metal, Acacia	22.5"RND 22.75"H	\$283.00	\$404.29	

QTY	CODE	ITEM	DETAILS	DIMENSIONS	DISCOUNT PRICE	STANDARD PRICE	TOTAL
	TABLES (continued)						
	PSETAC	Posh End Table	LED Lighted w/ AC Plug		\$670.00	\$957.14	
	PSETDC	Posh End Table	LED Lighted w/ DC		\$670.00	\$957.14	
	PSETUL	Posh End Table	Unit		\$505.00	\$721.43	
	PRBTAC	Posh Round Bar Table	LED Lighted w/ AC Plug		\$880.00	\$1,257.14	
	PRBTDC	Posh Round Bar Table	LED Lighted w/ DC		\$880.00	\$1,257.14	
	PRBTUL	Posh Round Bar Table	Unit		\$613.00	\$875.71	
	BKCT10N	10' Table	Black Top, Silver	120"L 48"D 29"H	\$1,390.00	\$1,985.71	
	30WDHB	30" Round Bar Table w/ Hydraulic Base	Barnwood Top	30"RND 45"H	\$385.00	\$550.00	
	30BKHB	30" Round Bar Table w/ Hydraulic Base	Black Top	30"RND 45"H	\$385.00	\$550.00	
	30BEHB	30" Round Bar Table w/ Hydraulic Base	Blue Top	30"RND 45"H	\$385.00	\$550.00	
	30AGHB	30" Round Bar Table w/ Hydraulic Base	Brushed Gunmetal Top	30"RND 45"H	\$385.00	\$550.00	
	30YSHB	30" Round Bar Table w/ Hydraulic Base	Brushed Yellow Top	30"RND 45"H	\$385.00	\$550.00	
	30GRHB	30" Round Bar Table w/ Hydraulic Base	Graphite Nebula Top	30"RND 45"H	\$385.00	\$550.00	
	30GSHB	30" Round Bar Table w/ Hydraulic Base	Green Top	30"RND 45"H	\$385.00	\$550.00	
	30MTHB	30" Round Bar Table w/ Hydraulic Base	Maple Top	30"RND 45"H	\$385.00	\$550.00	
	30OSHB	30" Round Bar Table w/ Hydraulic Base	Orange Top	30"RND 45"H	\$385.00	\$550.00	
	30BRHB	30" Round Bar Table w/ Hydraulic Base	Red Top	30"RND 45"H	\$385.00	\$550.00	
	30WHHB	30" Round Bar Table w/ Hydraulic Base	White Top	30"RND 45"H	\$385.00	\$550.00	
	30WDDB	30" Round Bar Table w/ Standard Black Base	Barnwood Top	30"RND 42"H	\$265.00	\$378.57	
	30BKSB	30" Round Bar Table w/ Standard Black Base	Black Top	30"RND 42"H	\$265.00	\$378.57	
	30EBBB	30" Round Bar Table w/ Standard Black Base	Blue Top	30"RND 42"H	\$265.00	\$378.57	
	30AGBB	30" Round Bar Table w/ Standard Black Base	Brushed Gunmetal Top	30"RND 42"H	\$265.00	\$378.57	
	30YBBB	30" Round Bar Table w/ Standard Black Base	Brushed Yellow Top	30"RND 42"H	\$265.00	\$378.57	
	VTJ	30" Round Bar Table w/ Standard Black Base	Graphite Nebula Top	30"RND 42"H	\$265.00	\$378.57	
	30GSBB	30" Round Bar Table w/ Standard Black Base	Green Top	30"RND 42"H	\$265.00	\$378.57	
	VTK	30" Round Bar Table w/ Standard Black Base	Maple Top	30"RND 42"H	\$265.00	\$378.57	
	30OSBB	30" Round Bar Table w/ Standard Black Base	Orange Top	30"RND 42"H	\$265.00	\$378.57	
	VTB	30" Round Bar Table w/ Standard Black Base	Red Top	30"RND 42"H	\$265.00	\$378.57	
	30WH42	30" Round Bar Table w/ Standard Black Base	White Top	30"RND 42"H	\$265.00	\$378.57	
	30WDHC	30" Round Cafe Table w/ Hydraulic Base	Barnwood Top	30"RND 29"H	\$385.00	\$550.00	
	30BKHC	30" Round Cafe Table w/ Hydraulic Base	Black Top	30"RND 29"H	\$385.00	\$550.00	
	30BEHC	30" Round Cafe Table w/ Hydraulic Base	Blue Top	30"RND 29"H	\$385.00	\$550.00	
	30AGHC	30" Round Cafe Table w/ Hydraulic Base	Brushed Gunmetal Top	30"RND 29"H	\$385.00	\$550.00	
	30YSHC	30" Round Cafe Table w/ Hydraulic Base	Brushed Yellow Top	30"RND 29"H	\$385.00	\$550.00	
	30GRHC	30" Round Cafe Table w/ Hydraulic Base	Graphite Nebula Top	30"RND 29"H	\$385.00	\$550.00	
	30GSHC	30" Round Cafe Table w/ Hydraulic Base	Green Top	30"RND 29"H	\$385.00	\$550.00	
	30MTHC	30" Round Cafe Table w/ Hydraulic Base	Maple Top	30"RND 29"H	\$385.00	\$550.00	
	30OSHC	30" Round Cafe Table w/ Hydraulic Base	Orange Top	30"RND 29"H	\$385.00	\$550.00	
	30BRHC	30" Round Cafe Table w/ Hydraulic Base	Red Top	30"RND 29"H	\$385.00	\$550.00	
	30WHHC	30" Round Cafe Table w/ Hydraulic Base	White Top	30"RND 29"H	\$385.00	\$550.00	
	30WDBC	30" Round Cafe Table w/ Standard Black Base	Barnwood Top	30"RND 29"H	\$265.00	\$378.57	
	30BKSC	30" Round Cafe Table w/ Standard Black Base	Black Top	30"RND 29"H	\$265.00	\$378.57	
	30EBEC	30" Round Cafe Table w/ Standard Black Base	Blue Top	30"RND 29"H	\$265.00	\$378.57	
	30AGBC	30" Round Cafe Table w/ Standard Black Base	Brushed Gunmetal Top	30"RND 29"H	\$265.00	\$378.57	
	30YSBC	30" Round Cafe Table w/ Standard Black Base	Brushed Yellow Top	30"RND 29"H	\$265.00	\$378.57	
	ZTJ	30" Round Cafe Table w/ Standard Black Base	Graphite Nebula Top	30"RND 29"H	\$265.00	\$378.57	
	30GSBC	30" Round Cafe Table w/ Standard Black Base	Green Top	30"RND 29"H	\$265.00	\$378.57	
	ZTK	30" Round Cafe Table w/ Standard Black Base	Maple Top	30"RND 29"H	\$265.00	\$378.57	
	30OSBC	30" Round Cafe Table w/ Standard Black Base	Orange Top	30"RND 29"H	\$265.00	\$378.57	
	ZTB	30" Round Cafe Table w/ Standard Black Base	Red Top	30"RND 29"H	\$265.00	\$378.57	
	30WH29	30" Round Cafe Table w/ Standard Black Base	White Top	30"RND 29"H	\$265.00	\$378.57	
	30MAHB	30" Round Madison Bar Table w/ Hydraulic Base	Gray Acajou Top	30"RND 45"H	\$385.00	\$550.00	
	VTA	30" Round Madison Bar Table w/ Standard Black Base	Gray Acajou Top	30"RND 42"H	\$265.00	\$378.57	
	30MAHC	30" Round Madison Cafe Table w/ Hydraulic Base	Gray Acajou Top	30"RND 29"H	\$385.00	\$550.00	
	ZTA	30" Round Madison Cafe Table w/ Standard Black Base	Gray Acajou Top	30"RND 29"H	\$265.00	\$378.57	
	36BKHB	36" Round Bar Table w/ Hydraulic Base	Black Top	36"RND 45"H	\$418.00	\$597.14	
	36GRHB	36" Round Bar Table w/ Hydraulic Base	Graphite Nebula Top	36"RND 45"H	\$418.00	\$597.14	
	36MTHB	36" Round Bar Table w/ Hydraulic Base	Maple Top	36"RND 45"H	\$418.00	\$597.14	
	36WTHB	36" Round Bar Table w/ Hydraulic Base	White Top	36"RND 45"H	\$418.00	\$597.14	
	36BKSB	36" Round Bar Table w/ Standard Black Base	Black Top	36"RND 42"H	\$313.00	\$447.14	
	VTN	36" Round Bar Table w/ Standard Black Base	Graphite Nebula Top	36"RND 42"H	\$313.00	\$447.14	
	VTW	36" Round Bar Table w/ Standard Black Base	White Top	36"RND 42"H	\$313.00	\$447.14	
	36BKHC	36" Round Cafe Table w/ Hydraulic Base	Black Top	36"RND 29"H	\$418.00	\$597.14	
	36MTHC	36" Round Cafe Table w/ Hydraulic Base	Maple Top	36"RND 29"H	\$418.00	\$597.14	
	36BKSC	36" Round Cafe Table w/ Standard Black Base	Black Top	36"RND 29"H	\$313.00	\$447.14	
	ZTN	36" Round Cafe Table w/ Standard Black Base	Graphite Nebula Top	36"RND 29"H	\$313.00	\$447.14	
	ZTP	36" Round Cafe Table w/ Standard Black Base	Maple Top	36"RND 29"H	\$313.00	\$447.14	
	ZTQ	36" Round Cafe Table w/ Standard Black Base	White Top	36"RND 29"H	\$313.00	\$447.14	
	VTP	36" Round Bar Table w/ Standard Black Base	Maple Top	36"RND 42"H	\$313.00	\$447.14	
	36GRHC	36" Round Cafe Table w/ Hydraulic Base	Graphite Nebula Top	36"RND 29"H	\$418.00	\$597.14	
	36WTHC	36" Round Cafe Table w/ Hydraulic Base	White Top	36"RND 29"H	\$418.00	\$597.14	
	CB8	42" Round Madison Table	Gray Acajou, Black	42"RND 29"H	\$493.00	\$704.29	
	42BKCT	42" Round Table	Black Top, Black	42"RND 29"H	\$493.00	\$704.29	
	CONF42	42" Round Table	White Top	42"RND 29"H	\$493.00	\$704.29	
	BKCT5N	5' Table	Black Top, Silver	60"L 48"D 29"H	\$720.00	\$1,028.57	
	BKCT5P	5' Table, Powered	Black Top, Silver	60"L 48"D 29"H	\$1,228.00	\$1,754.29	
	BKCT8N	8' Table	Black Top, Silver	96"L 60"D 29"H	\$1,228.00	\$1,754.29	
	BKCT8P	8' Table, Powered	Black Top, Silver	96"L 60"D 29"H	\$2,363.00	\$3,375.71	
	ADCTBK	Adelaide Cocktail Table	Black Top, Silver	48.875"L 25.375"D 18"H	\$418.00	\$597.14	
	ADCTGL	Adelaide Cocktail Table	Glass Top, Silver	48.875"L 25.375"D 18"H	\$418.00	\$597.14	
	ADCTWH	Adelaide Cocktail Table	White Top, Silver	48.875"L 25.375"D 18"H	\$418.00	\$597.14	
	ADETBK	Adelaide End Table	Black Top, Silver	21.5"L 21.5"D 18"H	\$405.00	\$578.57	
	ADETGL	Adelaide End Table	Glass Top, Silver	21.5"L 21.5"D 18"H	\$405.00	\$578.57	
	ADETWH	Adelaide End Table	White Top, Silver	21.5"L 21.5"D 18"H	\$405.00	\$578.57	

QTY	CODE	ITEM	DETAILS	DIMENSIONS	DISCOUNT PRICE	STANDARD PRICE	TOTAL
TABLES (continued)							
	ALC200	Alondra Cocktail Table	Brandy Maple Top, Chrome	47"L 24"D 17"H	\$428.00	\$611.43	
	ALC100	Alondra Cocktail Table	Glass Top, Chrome	47"L 24"D 16"H	\$428.00	\$611.43	
	ALE200	Alondra End Table	Brandy Maple Top, Chrome	20"L 20"D 21"H	\$310.00	\$442.86	
	ALE100	Alondra End Table	Glass Top, Chrome	20"L 20"D 20"H	\$310.00	\$442.86	
	36ATO	Atomic 36" Round Table	Glass Top, Chrome	36"RND 30"H	\$410.00	\$585.71	
	42ATO	Atomic 42" Round Table	Glass Top, Chrome	42"RND 30"H	\$410.00	\$585.71	
	AURA	Aura Round Table	White Metal	15"RND 22"H	\$188.00	\$268.57	
	CIFWB	Geo Cocktail Table	Brandy Maple Top, Black	47"L 24"D 17"H	\$375.00	\$535.71	
	C1C	Geo Cocktail Table	Glass Top, Chrome	50"L 22"D 16"H	\$323.00	\$461.43	
	EIFWB	Geo End Table	Brandy Maple Top, Black	20"L 20"D 21"H	\$328.00	\$468.57	
	E1C	Geo End Table	Glass Top, Chrome	24"L 24"D 20"H	\$265.00	\$378.57	
	CF2	Geo Table, Rectangle	Glass Top, Black	60"L 36"D 29"H	\$578.00	\$825.71	
	CE2	Geo Table, Rectangle	Glass Top, Chrome	60"L 36"D 29"H	\$578.00	\$825.71	
	CF1	Geo Table, Rounded Square	Glass Top, Black	42"L 42"D 29"H	\$410.00	\$585.71	
	CE1	Geo Table, Rounded Square	Glass Top, Chrome	42"L 42"D 29"H	\$410.00	\$585.71	
	MADC10	Madison 10' Table	Gray Acajou, Silver	120"L 48"D 29"H	\$1,228.00	\$1,754.29	
	MADC05	Madison 5' Table	Gray Acajou, Silver	60"L 48"D 29"H	\$613.00	\$875.71	
	MADC08	Madison 8' Table	Gray Acajou, Silver	96"L 60"D 29"H	\$1,228.00	\$1,754.29	
	MESCTW	Mesa Cocktail Table	Barnwood Top, Bronze	32.25"RND 17.25"H	\$275.00	\$392.86	
	MESCTB	Mesa Cocktail Table	Black Top, Bronze	32.25"RND 17.25"H	\$275.00	\$392.86	
	MESCTG	Mesa Cocktail Table	Glass Top, Bronze	36"RND 17.25"H	\$275.00	\$392.86	
	MESETW	Mesa End Table	Barnwood Top, Bronze	20.5"RND 21.25"H	\$180.00	\$257.14	
	MESETB	Mesa End Table	Black Top, Bronze	20.5"RND 21.25"H	\$180.00	\$257.14	
	MESETG	Mesa End Table	Glass Top, Bronze	24"RND 21.25"H	\$180.00	\$257.14	
	REGOTT	Regis End Table	Brushed Metal	16"L 15.5"D 16.5"H	\$350.00	\$500.00	
	RSTSQT	Rustique Square Metal Bar Table	Gunmetal	23.75"L 23.75"D 41.25"H	\$350.00	\$500.00	
	SEDBWD	Sedona Side Table	Barnwood Top, Bronze	15.75"L 15.75"D 24"H	\$180.00	\$257.14	
	SEDBBK	Sedona Side Table	Black Top, Bronze	15.75"L 15.75"D 24"H	\$180.00	\$257.14	
	SEDBWH	Sedona Side Table	White Top, Bronze	15.75"L 15.75"D 24"H	\$180.00	\$257.14	
	C1E	Silverado Cocktail Table	Glass Top, Chrome	36"RND 17"H	\$358.00	\$511.43	
	E1E	Silverado End Table	Glass, Chrome	24"RND 22"H	\$280.00	\$400.00	
	SYDWDC	Sydney Cocktail Table	Barnwood Top, Brushed Steel	48"L 26"D 18"H	\$410.00	\$585.71	
	C1Y	Sydney Cocktail Table	Black Top, Brushed Steel	48"L 26"D 18"H	\$360.00	\$514.29	
	SYDBEC	Sydney Cocktail Table	Blue Top, Brushed Steel	48"L 26"D 18"H	\$410.00	\$585.71	
	C1W	Sydney Cocktail Table	White Top, Brushed Steel	48"L 26"D 18"H	\$360.00	\$514.29	
	SYDWDE	Sydney End Table	Barnwood Top, Brushed Steel	27"L 23"D 22"H	\$358.00	\$511.43	
	E1Y	Sydney End Table	Black Top, Brushed Steel	27"L 23"D 22"H	\$328.00	\$468.57	
	SYDBEE	Sydney End Table	Blue Top, Brushed Steel	27"L 23"D 22"H	\$358.00	\$511.43	
	E1W	Sydney End Table	White Top, Brushed Steel	27"L 23"D 22"H	\$328.00	\$468.57	
	TAOBWD	Taos Side Table	Barnwood Top, Bronze	15.75"L 15.75"D 24"H	\$180.00	\$257.14	
	TAOBK	Taos Side Table	Black Top, Bronze	15.75"L 15.75"D 24"H	\$180.00	\$257.14	
	TAOBWH	Taos Side Table	White Top, Bronze	15.75"L 15.75"D 24"H	\$180.00	\$257.14	
	TMBTBL	Timber Table	Wood	16"RND 17"H	\$195.00	\$278.57	
	VNTBNP	Ventura Communal Bar Table	Black Top, Silver	72.25"L 26.25"D 42"H	\$853.00	\$1,218.57	
	VNTMNP	Ventura Communal Bar Table	Maple Top, Silver	72.25"L 26.25"D 42"H	\$853.00	\$1,218.57	
	VNTWNP	Ventura Communal Bar Table	White Top, Silver	72.25"L 26.25"D 42"H	\$853.00	\$1,218.57	
	VNTBMW	Ventura Communal Bar Table w/ Grommet Holes	Maple Top, Silver	72.25"L 26.25"D 42"H	\$853.00	\$1,218.57	
	VNTBWW	Ventura Communal Bar Table w/ Grommet Holes	White Top, Silver	72.25"L 26.25"D 42"H	\$853.00	\$1,218.57	
	VNTCBN	Ventura Communal Cafe Table	Black Top, Silver	72.25"L 26.25"D 30"H	\$715.00	\$1,021.43	
	VNTCMN	Ventura Communal Cafe Table	Maple Top, Silver	72.25"L 26.25"D 30"H	\$715.00	\$1,021.43	
	VNTCWN	Ventura Communal Cafe Table	White Top, Silver	72.25"L 26.25"D 30"H	\$715.00	\$1,021.43	
	VNTCMW	Ventura Communal Cafe Table w/ Grommet Holes	Maple Top, Silver	72.25"L 26.25"D 30"H	\$715.00	\$1,021.43	
	VNTCWW	Ventura Communal Cafe Table w/ Grommet Holes	White Top, Silver	72.25"L 26.25"D 30"H	\$715.00	\$1,021.43	
	WD3	Work Table	White Top, White	48"L 24"D 30"H	\$425.00	\$607.14	
	CONF10	10' Table	White Top, Silver	120"L 48"D 29"H	\$1,390.00	\$1,985.71	
	CONF5	5' Table	White Top, Silver	60"L 48"D 29"H	\$720.00	\$1,028.57	
	CONF8	8' Table	White Top, Silver	96"L 60"D 29"H	\$1,390.00	\$1,985.71	
	GRCI0N	10' Table	Graphite Top, Silver	120"L 48"D 29"H	\$1,390.00	\$1,985.71	
	GRCI0P	10' Table, Powered	Graphite Top, Silver	120"L 48"D 29"H	\$1,715.00	\$2,450.00	
	30ABHB	30" Round Bar Table w/ Black Hydraulic Base	Azure Blue Top	30"RND 45"H	\$385.00	\$550.00	
	30NHBB	30" Round Bar Table w/ Black Hydraulic Base	Barnwood Top	30"RND 45"H	\$385.00	\$550.00	
	30BBHB	30" Round Bar Table w/ Black Hydraulic Base	Black Top	30"RND 45"H	\$385.00	\$550.00	
	30BBHB	30" Round Bar Table w/ Black Hydraulic Base	Blue Top	30"RND 45"H	\$385.00	\$550.00	
	30AHBB	30" Round Bar Table w/ Black Hydraulic Base	Brushed Gunmetal Top	30"RND 45"H	\$385.00	\$550.00	
	30YBHB	30" Round Bar Table w/ Black Hydraulic Base	Brushed Yellow Top	30"RND 45"H	\$385.00	\$550.00	
	30CBHB	30" Round Bar Table w/ Black Hydraulic Base	Chartreuse Top	30"RND 45"H	\$385.00	\$550.00	
	30FBHB	30" Round Bar Table w/ Black Hydraulic Base	Fuchsia Top	30"RND 45"H	\$385.00	\$550.00	
	30GHBB	30" Round Bar Table w/ Black Hydraulic Base	Graphite Nebula Top	30"RND 45"H	\$385.00	\$550.00	
	30GBHB	30" Round Bar Table w/ Black Hydraulic Base	Green Top	30"RND 45"H	\$385.00	\$550.00	
	30MHBB	30" Round Bar Table w/ Black Hydraulic Base	Maple Top	30"RND 45"H	\$385.00	\$550.00	
	30OBHB	30" Round Bar Table w/ Black Hydraulic Base	Orange Top	30"RND 45"H	\$385.00	\$550.00	
	30RHBB	30" Round Bar Table w/ Black Hydraulic Base	Red Top	30"RND 45"H	\$385.00	\$550.00	
	30WHBB	30" Round Bar Table w/ Black Hydraulic Base	White Top	30"RND 45"H	\$385.00	\$550.00	
	30AZHB	30" Round Bar Table w/ Hydraulic Base	Azure Blue Top	30"RND 45"H	\$385.00	\$550.00	
	30CSHB	30" Round Bar Table w/ Hydraulic Base	Chartreuse Top	30"RND 45"H	\$385.00	\$550.00	
	30FSHB	30" Round Bar Table w/ Hydraulic Base	Fuchsia Top	30"RND 45"H	\$385.00	\$550.00	
	30AZSB	30" Round Bar Table w/ Standard Black Base	Azure Blue Top	30"RND 42"H	\$265.00	\$378.57	
	30CSBB	30" Round Bar Table w/ Standard Black Base	Chartreuse Top	30"RND 42"H	\$265.00	\$378.57	
	30FSBB	30" Round Bar Table w/ Standard Black Base	Fuchsia Top	30"RND 42"H	\$265.00	\$378.57	
	30ABHC	30" Round Cafe Table w/ Black Hydraulic Base	Azure Blue Top	30"RND 29"H	\$385.00	\$550.00	
	30NHBC	30" Round Cafe Table w/ Black Hydraulic Base	Barnwood Top	30"RND 29"H	\$385.00	\$550.00	
	30BBHC	30" Round Cafe Table w/ Black Hydraulic Base	Black Top	30"RND 29"H	\$385.00	\$550.00	
	30BHBC	30" Round Cafe Table w/ Black Hydraulic Base	Blue Top	30"RND 29"H	\$385.00	\$550.00	
	30AHBC	30" Round Cafe Table w/ Black Hydraulic Base	Brushed Gunmetal Top	30"RND 29"H	\$385.00	\$550.00	

QTY	CODE	ITEM	DETAILS	DIMENSIONS	DISCOUNT PRICE	STANDARD PRICE	TOTAL
TABLES (continued)							
	30YBHC	30" Round Cafe Table w/ Black Hydraulic Base	Brushed Yellow Top	30"RND 29"H	\$385.00	\$550.00	
	30CBHC	30" Round Cafe Table w/ Black Hydraulic Base	Chartreuse Top	30"RND 29"H	\$385.00	\$550.00	
	30FBHC	30" Round Cafe Table w/ Black Hydraulic Base	Fuchsia Top	30"RND 29"H	\$385.00	\$550.00	
	30GHBC	30" Round Cafe Table w/ Black Hydraulic Base	Graphite Nebula Top	30"RND 29"H	\$385.00	\$550.00	
	30GBHC	30" Round Cafe Table w/ Black Hydraulic Base	Green Top	30"RND 29"H	\$385.00	\$550.00	
	30MHBC	30" Round Cafe Table w/ Black Hydraulic Base	Maple Top	30"RND 29"H	\$385.00	\$550.00	
	30OBHC	30" Round Cafe Table w/ Black Hydraulic Base	Orange Top	30"RND 29"H	\$385.00	\$550.00	
	30RHBC	30" Round Cafe Table w/ Black Hydraulic Base	Red Top	30"RND 29"H	\$385.00	\$550.00	
	30WHBC	30" Round Cafe Table w/ Black Hydraulic Base	White Top	30"RND 29"H	\$385.00	\$550.00	
	30AZHC	30" Round Cafe Table w/ Hydraulic Base	Azure Blue Top	30"RND 29"H	\$385.00	\$550.00	
	30CSHC	30" Round Cafe Table w/ Hydraulic Base	Chartreuse Top	30"RND 29"H	\$385.00	\$550.00	
	30FSHC	30" Round Cafe Table w/ Hydraulic Base	Fuchsia Top	30"RND 29"H	\$385.00	\$550.00	
	30AZBC	30" Round Cafe Table w/ Standard Black Base	Azure Blue Top	30"RND 29"H	\$265.00	\$378.57	
	30CSBC	30" Round Cafe Table w/ Standard Black Base	Chartreuse Top	30"RND 29"H	\$265.00	\$378.57	
	30FSBC	30" Round Cafe Table w/ Standard Black Base	Fuchsia Top	30"RND 29"H	\$265.00	\$378.57	
	30UHBB	30" Round Madison Bar Table w/ Black Hydraulic Base	Gray Acajou Top	30"RND 45"H	\$385.00	\$550.00	
	30UHBC	30" Round Madison Cafe Table w/ Black Hydraulic Base	Gray Acajou Top	30"RND 29"H	\$385.00	\$550.00	
	36BBHB	36" Round Bar Table w/ Black Hydraulic Base	Black Top	36"RND 45"H	\$418.00	\$597.14	
	36GHBB	36" Round Bar Table w/ Black Hydraulic Base	Graphite Nebula Top	36"RND 45"H	\$418.00	\$597.14	
	36MHBB	36" Round Bar Table w/ Black Hydraulic Base	Maple Top	36"RND 45"H	\$418.00	\$597.14	
	36WHBB	36" Round Bar Table w/ Black Hydraulic Base	White Top	36"RND 45"H	\$418.00	\$597.14	
	36BBHC	36" Round Cafe Table w/ Black Hydraulic Base	Black Top	36"RND 29"H	\$418.00	\$597.14	
	36GHBC	36" Round Cafe Table w/ Black Hydraulic Base	Graphite Nebula Top	36"RND 29"H	\$418.00	\$597.14	
	36MHBC	36" Round Cafe Table w/ Black Hydraulic Base	Maple Top	36"RND 29"H	\$418.00	\$597.14	
	36WHBC	36" Round Cafe Table w/ Black Hydraulic Base	White Top	36"RND 29"H	\$418.00	\$597.14	
	GRCT5N	5' Table	Graphite Top, Silver	60"L 48"D 29"H	\$720.00	\$1,028.57	
	GRCS5P	5' Table, Powered	Graphite Top, Silver	60"L 48"D 29"H	\$1,228.00	\$1,754.29	
	GRCT8N	8' Table	Graphite Top, Silver	96"L 60"D 29"H	\$1,228.00	\$1,754.29	
	GRCT8P	8' Table, Powered	Graphite Top, Silver	96"L 60"D 29"H	\$1,715.00	\$2,450.00	
	ALC300	Alondra Cocktail Table	Marble Top, Chrome	47"L 24"D 17"H	\$498.00	\$711.43	
	ALE300	Alondra End Table	Marble Top, Chrome	20"L 20"D 21"H	\$360.00	\$514.29	
	BOCCTL	Boca Cocktail Table	Brown, Glass Top	28"L 28"D 12"H	\$265.00	\$378.57	
	BRETBK	Brisbane Side Table	Black, Black	25" RND 20"H	\$328.00	\$468.57	
	BRETLG	Brisbane Side Table	Glass, Black	25" RND 20"H	\$328.00	\$468.57	
	CAPCOC	Capri Cocktail Table	Beech Wood-Look Metal	50.5"L 24"D 17"H	\$350.00	\$500.00	
	CAPEND	Capri End Table	Beech Wood-Look Metal	22.25"L 22.25"D 21"H	\$258.00	\$368.57	
	CAYMST	Cayman Side Table	Black Wood	11" RND x 22"H	\$225.00	\$321.43	
	GALCKB	Galactic Cocktail Table	Sienna Brown	27.5"L 24"D 17.5"H	\$298.00	\$425.71	
	GALETO	Galactic Side Table	Spice Orange	20.75"L 18"D 22"H	\$340.00	\$485.71	
	GEOCCW	Geo Cocktail Table	Brandy Maple Top, Chrome	47"L 24"D 17"H	\$350.00	\$500.00	
	GEOGCW	Geo Cocktail Table	Brandy Maple Top, Gold	47"L 24"D 17"H	\$350.00	\$500.00	
	CIF	Geo Cocktail Table	Glass Top, Black	50"L 22"D 16"H	\$350.00	\$500.00	
	GEOGCG	Geo Cocktail Table	Glass Top, Gold	50"L 22"D 16"H	\$350.00	\$500.00	
	CIMB	Geo Cocktail Table	Marble Top, Black	47"L 24"D 17"H	\$413.00	\$590.00	
	GEOCCM	Geo Cocktail Table	Marble Top, Chrome	47"L 24"D 17"H	\$350.00	\$500.00	
	GEOGCM	Geo Cocktail Table	Marble Top, Gold	47"L 24"D 17"H	\$350.00	\$500.00	
	GEOCEW	Geo End Table	Brandy Maple Top, Chrome	20"L 20"D 21"H	\$283.00	\$404.29	
	GEOGEW	Geo End Table	Brandy Maple Top, Gold	20"L 20"D 21"H	\$283.00	\$404.29	
	EIF	Geo End Table	Glass Top, Black	24"L 24"D 20"H	\$283.00	\$404.29	
	GEOGEG	Geo End Table	Glass Top, Gold	24"L 24"D 20"H	\$283.00	\$404.29	
	EIMB	Geo End Table	Marble Top, Black	20"L 20"D 21"H	\$335.00	\$478.57	
	GEOCEM	Geo End Table	Marble Top, Chrome	20"L 20"D 21"H	\$283.00	\$404.29	
	GEOGEM	Geo End Table	Marble Top, Gold	20"L 20"D 21"H	\$283.00	\$404.29	
	JACOWD	Jacob Wood Table	Mango Wood	14"L 14"D 24"H	\$275.00	\$392.86	
	POSTAB	Posh Bar Table	Chrome/Acrylic	29"L 26"D 40"H	\$500.00	\$714.29	
	RSTBAR	Rustique Communal Bar Table	Wood	65"L 35.5"D 42"H	\$833.00	\$1,190.00	
	RSTCAF	Rustique Communal Cafe Table	Wood	65"L 35.5"D 31"H	\$695.00	\$992.86	
	SOFETG	Sofia Side Table	Antique Black	15.5"L 12.5"D 22"H	\$233.00	\$332.86	
	SONBAR	Sonoma 24" Round Outdoor Bar Table	White Top, Black	24"RND 42"H	\$350.00	\$500.00	
	SONCAF	Sonoma 32" Round Outdoor Cafe Table	White Top, Black	32" RND 30"H	\$268.00	\$382.86	
	THITAB	Thira Table	Gray Marble Top, Bronze Base	30"RND 16"H	\$540.00	\$771.43	
	TWIETB	Twist Side Table	Antique Brass, Black	14"L 14"D 22"H	\$338.00	\$482.86	

TOTAL

Sales Tax 8.25% \$ _____

Estimated Furniture Rental Total..... \$ _____

Email this completed form to: orders@t3expo.com

Company Name: _____

Contact Name: _____

Email Address: _____

Cell Phone: _____

Booth #: _____

ADDITIONAL INFORMATION & FORMS

Payment Information

Important Information

*If paying by check or wire, T3 also requires a Credit Card as a contingency should either check or wire not clear in time to place your orders.

*Please make payable to T3 Expo, and mail to:

T3 Expo
8 Lakeville Business Park
Lakeville, MA 02347

Credit Card will be charged for items ordered if intended method of payment is not received at least two weeks prior to the first move in day of the event.

**Wire details will be sent to the contact email address upon receipt of this form.

Notwithstanding anything to the contrary in this Agreement, Exhibiting Company shall have the ultimate responsibility for the payment of all applicable fees as set forth and in accordance with the schedule set forth. Exhibiting Company's obligation to make payment in accordance with the schedule shall under no circumstances be relieved or excused due to the failure of any third party to issue payments on Exhibitor's behalf.

T3 Expo reserves all rights to withhold services should full payment not be received and cleared prior to the first day of move-in.

Accepted Credit Cards:

- Visa
- Mastercard
- American Express

T3 will use this authorization to charge your credit card for any additional subsequent orders placed by you or your representative for services rendered to your company for this event.

PLEASE NOTE: There is a 25% cancellation fee for any items that are cancelled more than 21 days prior to the first day of move-in. There is a 50% cancellation fee for all items that are cancelled 7-21 days prior to the first day of move-in and 100% cancellation fee for any items that are cancelled less than 7 days prior to the first day of move-in on 11/18/24.

Services Ordered

Material Handling	= \$ _____
Vehicle Spotting Fee	= \$ _____
Cartload Service.....	= \$ _____
Presta™ Rental Exhibit Packages	= \$ _____
Booth Packages	= \$ _____
Carpet.....	= \$ _____
Furniture & Accessories	= \$ _____
Display Tables & Counters.....	= \$ _____
Display Labor & Forklift	= \$ _____
Hanging Sign.....	= \$ _____
Accessible Storage & Cleaning	= \$ _____
AFR Furniture.....	= \$ _____
Custom Furniture	= \$ _____
Total:	\$ _____

Exhibitor Profile

Company Name:		Booth #:
Street Address:		City:
State:	Zip:	Country:
Contact Name:		Email Address:
Cell Phone: ()	Fax: ()	

Method of Payment

Company Check*
(Checks must be in U.S. Funds, payable to T3 Expo)

Wire Transfer**
Credit Card

Credit Card Information

Exhibiting Company:		Booth #:
Cardholder Name:		Email Address:
Account Number:	Card Type:	Expiration Date:
Signature:		CCID#:
Cardholder Billing Address:		
City/State/Zip:		

**Please Return EAC Form By:
Friday, October 18, 2024**

Notification Of Intent To Use EAC

Important Information

Inform your Exhibitor Appointed Contractor (EAC) that they **MUST** send a copy of their General Liability Insurance Certificate no later than 30 days prior to the first day of exhibitor move in or they will not be permitted to service your exhibit.

You **MUST** include the Exhibitor Name and Booth # under the Description of Operations section on the Certificate of Insurance.

It is the responsibility of the exhibitor to see that each representative of an EAC abides by the official rules and regulations of this event.

If your company plans to use a firm which is not the official service contractor as designated by Show Management, please complete this form and mail or email to the address listed below.

Please return to: **T3 Expo**
8 Lakeville Business Park
Lakeville, MA 02347
RE: Ag Aviation Expo 2024

Phone: +1.888.698.3397
Email: orders@t3expo.com

Exhibiting Company Information

Company Name:	Booth Number:
Contact Name:	
Signature:	Date:

Exhibitor Appointed Contractor Information

EAC Company Name:	
EAC Contact Name:	
EAC Address:	
City/State/Zip:	
Contact Email Address:	
Phone: ()	Fax: ()
Type of Service to be Performed:	

Third Party Authorization

Important Information

"We understand and agree that we, the exhibiting company, are ultimately responsible for payment of charges and agree by submitting this form or ordering materials or services from T3 Expo, to be bound by all terms and conditions as described in the Terms & Conditions section of this service manual. In the event that the named third party does not discharge payment of the invoice prior to the last day of the show, charges will revert back to the exhibiting company.

All invoices are due and payable upon receipt, by either party. The items checked below are to be invoiced to the third party."

T3 Expo reserves all rights to withhold services should full payment not be received and cleared prior to the first day of move-in. Notwithstanding anything to the contrary in this Agreement, Exhibiting Company shall have the ultimate responsibility for the payment of all applicable fees as set forth and in accordance with the schedule set forth. Exhibiting Company's obligation to make payment in accordance with the schedule shall under no circumstances be relieved or excused due to the failure of any third party to issue payments on Exhibitor's behalf.

Third Party covering the following charges for exhibitor:

- Material Handling
- Vehicle Spotting Fee
- Cartload Service
- Presta™ Rental Package
- Booth Package
- Carpet
- Furniture & Accessories
- Display Tables & Counters
- Display & Labor Forklift
- Hanging Sign
- Accessible Storage & Cleaning
- AFR Furniture
- Custom Furniture
- All Services

Exhibiting Company Authorization of Third Party Billing

Exhibitor Name:	Date:
Exhibitor Signature:	

Exhibiting Company Information

Exhibiting Company Name:	Booth Number:
Exhibiting Company Address:	
City/State/Zip:	
Contact Name:	Email Address:
Phone: ()	Fax: ()

Third Party Company Information

Third Party Company Name:	
Third Party Billing Address:	
City/State/Zip:	
Contact Name:	Email Address:
Phone: ()	Fax: ()
Third Party Responsible For (list services):	

Third Party Credit Card Authorization

Cardholder Name:	CCID #:	Expiration Date:
Account Number:		Card Type:
Authorized Signature:		
Card Holder Billing Address:		Email Address:
City/State/Zip:		

United States Fire Department Regulations

For Exhibits, Exhibitions, Displays and Trade Shows – Public & Private

Booth Construction

Booths, platforms and space dividers shall be of materials that are flame-retardant or rendered so, satisfactory to the Fire Department representatives. Coverings for counters or tables used within or as a part of the booth shall be flame-retardant. All electrical wiring and apparatus will be of a 3-wire UL approved type.

Fire Department

A permit shall be required for the following:

- 1) Display and operate any heater, barbecue, heat-producing or open flame device, candles, lamps, lanterns, torches, etc.
- 2) Display or operate any electrical, mechanical, or chemical device which may be deemed hazardous by the Fire Department.
- 3) Use or storage of inflammable liquids and dangerous chemicals.
- 4) Display any internal combustion engine (special requirements available upon request).
- 5) Use of compressed gases. (Permit available for 32CF bottles that are half full or less).

Obstructions

Aisles and exits, as designated on approved show plans, shall be kept clean, clear and free of obstacles. Booth construction shall be substantial and fixed in position in specified areas for the duration of the show. Easels, signs, etc., shall not be placed beyond the booth area into aisles. Firefighting equipment shall be provided and maintained in accessible, easily seen locations and may be required to be posted with designating signs.

Fire-Retardant Treatment

All decorations, drapes, signs, banners, acoustical materials, cotton, paper, hay straw, moss, split bamboo, plastic cloth, and similar materials shall be flame-retardant to the satisfaction of the Fire Department. Booth identification banners and signs shall be flame-retardant unless smaller than 1232 square inches (28" x 44") if separated from other combustibles by a minimum of 12" horizontally and 24" vertically. Oilcloth, tarpaper, nylon and certain other plastic materials cannot be made flame-retardant, and their use is prohibited.

Combustibles

Literature on display shall be limited to reasonable quantities (one-day supply). Reserve supplies shall be kept in closed containers and stored in a neat and compact manner in a location approved by the Fire Department. All exhibit and display empty cartons must be stored in an approved drayage area. If show is under a 24-hour approved manned security program, automobiles are allowed to retain one gallon or less of fuel, and gas caps must be taped. Batteries are to be disconnected and taped.

Storage behind booths is strictly prohibited.

Fort Worth Labor Guidelines

For Exhibits, Exhibitions, Displays and Trade Shows, Public & Private

To simplify show preparation, we are certain you will appreciate knowing in advance that labor will be required for certain aspects of your exhibit handling. To help you understand the show site work rules, we ask that you read the following:

Booth Labor, Freight and Rigging

Union personnel handle freight, carpet laying, and decorator functions. Additional Union personnel may be hired by the exhibitor through the General Contractor.

Rigging is handled by Union personnel and includes the unloading of heavy machinery and the hanging and assembly of signs. Plumbing is also handled by Union personnel.

The exhibitor in Dallas may use tools to set up and dismantle their own display. They may also hand-carry in small items, but may not use a hand cart or a dolly.

Electrical

Electrical services are handled in house at the Dallas Convention Center. Exhibitors may provide their own electrical cords, which must be 12 gauge, flat cords. The electrical power comes mainly from the floor in Dallas. Only electricians can lay the cords and plug in equipment. However, your installation and dismantle labor contractor may hang light boxes and other small items. Exhibitors may work on their own equipment, but again, only electricians may plug them in.

Hours

Straight time in Dallas is 8:00 am to 4:30 pm, Monday through Friday, except holidays. Lunch is 12:00 pm to 12:30 pm. Breaks are 10:00 am to 10:15 am and 2:30 pm to 2:45 pm.

Safety

Standing on chairs, tables, or other rental furniture is prohibited. This furniture is not engineered to support your standing weight. T3 Expo cannot be responsible for injuries or falls caused by the improper use of this furniture. If assistance is required in assembling your booth, labor can be ordered through T3 Expo by returning the Display Labor order form in this Exhibitor Service Kit in advance, or returning it on show site to T3 Expo's Service Desk.

Tipping

T3 Expo requests that exhibitors do not tip our employees. They are paid at an excellent wage scale denoting a professional status and we feel that tipping is not necessary; this applies to all employees. Any request for tipping should be brought to the attention of a T3 Expo representative at the Service Desk.

ANCILLARY INFORMATION & FORMS

NAAA Annual Ag Aviation Expo 2024

November 17-21, 2024

FORT WORTH CONVENTION CENTER



ELECTRICAL & PLUMBING

ORDER ONLINE TODAY!

Take advantage of discounted rates!

Order your electrical & plumbing services online by

10 / 27 / 2024

[ORDERING.EDLEN.COM](https://ordering.edlen.com)

Quick, secure, and easy to use!

You may receive an email to finalize your order from

ExhibitorServices-fortworth@edlen.com

EDLEN
The Power People

Edlen Electrical Exhibition Services

1201 Houston Street, Fort Worth, TX 76102

682.410.9336 • fortworth@edlen.com • www.edlen.com

ORDER INSTRUCTIONS

Advance Payment Deadline Date: 10/27/24



ELECTRICAL EXHIBITION SERVICES
1201 Houston Street, Fort Worth, TX 76102
Phone: (682) 410-9336
fortworth@edlen.com

EXHIBITOR:		BTH #	
EVENT:	NAAA Annual Aviation Expo 2024		
FACILITY:	Fort Worth Convention Center		
DATES:	November 17-21, 2024	EVENT #114004FW	

FOR YOUR CONVENIENCE PLACE YOUR ORDER ONLINE AT WWW.EDLEN.COM

COMPLETE THE STEPS BELOW TO PLACE UTILITY ORDERS

Step 1 Complete the Method of Payment

This form must be completed and returned with the order forms below.

Step 2 Complete Utility Order Forms as Required

- A. Electrical Order
- B. Plumbing Order

Step 3 Review Electrical Labor Instructions

This form will help you determine if you require electrical labor in your booth.

- A. What electrical work in your booth space needs to be performed by Edlen Electricians.
- B. How power is delivered to your booth in the facility (from the floor or ceiling).
- C. What other forms are required in order to schedule and pre-pay your estimated labor cost.

Step 4 Complete Additional Labor Forms as Required

Forms include the following:

A. Electrical Distribution

This form is used for the distribution of power on the floor in your booth space. The form should be completed by all island booths. Inline and peninsula booths need to provide this information only if power is required at any location other than the rear of the booth space.

B. Plumbing Distribution

This form is used for the distribution of air/water & drain services in your booth space. The form should be completed by all island booths. Inline and peninsula booths need to provide this information only if plumbing is required at any location other than the rear of the booth space.

Step 5 Complete the Electrical & Plumbing Layout Forms (if applicable)

All island booths must return an electrical layout and plumbing layout (if applicable) indicating a main distribution point as well as any other locations requiring power or plumbing services. Inline and peninsula booths need to return an electrical layout only if power is needed at any other location than the rear of the booth.

METHOD OF PAYMENT

Advance Payment Deadline Date: 10/27/24



ELECTRICAL EXHIBITION SERVICES
 1201 Houston Street, Fort Worth, TX 76102
 Phone: (682) 410-9336
 fortworth@edlen.com

EXHIBITOR:		BTH #	
EVENT:	NAAA Annual Aviation Expo 2024		
FACILITY:	Fort Worth Convention Center		
DATES:	November 17-21, 2024	EVENT #114004FW	

FINANCIALLY RESPONSIBLE COMPANY

COMPANY NAME:		PHONE:	
ADDRESS:		FAX:	
CITY:	ST:	ZIP:	
COUNTRY:		CELL #:	
EMAIL:			

METHOD OF PAYMENT

All transactions require a credit card on file with proper authorization. In addition to checks, Edlen accepts American Express, Mastercard, Visa, Discover, ACH and Wire Transfers. Indicate form of payment below.

ACH ELECTRONIC PAYMENT TRANSFER

JPMorgan Chase
 Routing #: 322271627 Acct #: 789835573
 Account Name: Edlen Electrical Exhibition Services, Inc

The financial institution MUST be based in the US. In order to avoid a transfer fee, you must notify the financial institution that you wish to make an ACH electronic payment transfer.

BANK WIRE TRANSFER INFORMATION *

Domestic & International JPMorgan Chase
 Routing #: 021000021 Acct #: 789835573
 Reference Address: 383 Madison Ave
 New York, NY 10017
 Swift Code: CHASUS33
 Account Name: Edlen Electrical Exhibition Services, Inc

*** Reference the Event # listed above and your Booth # on all electronic payments.**

*** \$50 processing fee MUST be included with transfer.**

MANUAL ORDER PROCESSING FEE *

Orders submitted for manual processing **MUST include a \$25 processing fee.** Submit orders online instead @ www.edlen.com

CREDIT CARD

We will use this authorization to charge any remaining balances on your account prior to event closing. A copy of final charges will be sent to the email address provided in the payment information section.

COMPANY CHECK

Make check payable to: Edlen Electrical. All foreign checks must be drawn on U.S. Banks only. Check must be received before the deadline date and you must include a credit card as a guarantee. Reference the Event # listed above on your remittance.

VISA MASTERCARD AMEX DISCOVER

CHECK AND CREDIT CARD INFORMATION

COMPANY NAME:											
CHECK #											
CREDIT CARD NUMBER:								EXP DATE:			
CARD HOLDER SIGN:						PRINT NAME:					
EMAIL:											
THIRD PARTY PAYMENT? YES or NO											

CREDIT CARD ADDRESS INFORMATION IF DIFFERENT THAN INFORMATION ABOVE

ADDRESS:	CITY:	ST:	ZIP:
-----------------	--------------	------------	-------------

SERVICE TOTALS

* MANUAL ORDER PROCESSING FEE	\$25.00
* BANK WIRE TRANSFER PROCESSING FEE	
2. ELECTRICAL ORDER	
3. ESTIMATED LABOR	
4. PLUMBING ORDER	
SUBTOTAL	
Sales tax is due unless exemption is provided	8.25% SALES TAX
TOTAL DUE	

AUTHORIZATION



AUTHORIZED SIGNATURE ABOVE

PRINT NAME ABOVE **TODAY'S DATE ABOVE**

By signing and placing this order, I accept all payment policies, terms and conditions outlined on all completed service order forms and the Edlen General Data Protection Regulation privacy policy.

ELECTRICAL EXHIBITION SERVICES
 1201 Houston Street, Fort Worth, TX 76102
 Phone: (682) 410-9336
 fortworth@edlen.com

EXHIBITOR:		BTH #	
EVENT:	NAAA Annual Aviation Expo 2024		
FACILITY:	Fort Worth Convention Center		
DATES:	November 17-21, 2024	EVENT #	114004FW

FOR YOUR CONVENIENCE PLACE YOUR ORDER ONLINE AT WWW.EDLEN.COM

ORDER INSTRUCTIONS

INLINE AND PENINSULA DELIVERY
 The cost of 120-Volt outlets includes delivery to one location at the rear of inline or peninsula booths. If you require the outlet(s) to be distributed to any other location(s), material and labor charges apply. There is a minimum charge of (1) hour for installation and (1/2) hour for removal. Complete and return the Electrical Distribution Form along with a floor plan layout of your booth space indicating outlet location(s).

ISLAND BOOTH DELIVERY ONE LOCATION
 Island booths that need power delivered to one location incur (1) hour labor charge for installation & (1/2) hour labor charge for removal. Return a floor plan layout of your booth space indicating the outlet location with measurements and orientation.

ISLAND BOOTH DELIVERY MULTIPLE LOCATIONS
 Island booths that require power to be delivered to multiple locations within their booth space incur a minimum (1) hour labor charge for installation. The removal of this work will be charged a minimum (1/2) hour or (1/2) the total time of installation. Material charges will apply. Return a floor plan layout of your booth space indicating a main distribution point and all outlet locations with measurements and orientation. If a main distribution point is not provided, Edlen will deliver to the most convenient location.

208/480V POWER DELIVERY AND CONNECTIONS
 Edlen electricians must make all high voltage connections and disconnections on a time and material basis. Complete the Electrical Booth Work Form to schedule your estimated connection time and labor. Return form with your order.

MOTOR POWER
 Order electrical services for motor power required on this form. If unsure of the electrical services required call for a quote.

24 HOUR SERVICES
 Electricity will be turned on within 30 minutes of show opening and off within 30 minutes of show closing, show days only. If you require power at any other time order 24 hour power at double the outlet rate.

CANCELLATIONS
 Credits will not be issued for services delivered and not used. See #16, 22 & 23 on Terms & Conditions for details.

TERMS & CONDITIONS
 I agree in placing this order that I have accepted Edlen's payment policy and the terms and conditions of the contract.

ELECTRICAL OUTLETS Approximately 120V/208V A.C. 60 Cycle - Prices are for Entire Event

	QTY Show Hours Only	QTY 24hrs/day Double	ADVANCE PAYMENT	REGULAR PAYMENT PRICE	TOTAL COST
Add 8.25% tax					
120 VOLT					
500 WATTS (5 AMPS)	_____	_____	77.00	115.00	_____
1000 WATTS (10 AMPS)	_____	_____	105.00	158.00	_____
2000 WATTS (20 AMPS)	_____	_____	130.00	195.00	_____
208 VOLT SINGLE PHASE					
20 AMPS	_____	_____	181.00	271.00	_____
30 AMPS	_____	_____	223.00	335.00	_____
60 AMP	_____	_____	295.00	397.00	_____
208 VOLT THREE PHASE					
20 AMPS	_____	_____	304.00	456.00	_____
30 AMPS	_____	_____	415.00	623.00	_____
60 AMPS	_____	_____	618.00	927.00	_____
100 AMPS	_____	_____	939.00	1408.00	_____
TRANSFORMER(S) Boost 208 Volt to 230 Volt					
Transformer (20 amp minimum charge)			Total Amps: _____ x 6.35 = _____		

LIGHTS (Cost of Arm & Pole lights include power. If ordering Par Can, then order a 1000 watt outlet for each Par Can. For Par Can installation, scissor lift charges apply.)

1000 WATT PAR CAN	_____	100.00	140.00	_____
8' POLE LIGHT—1 FIXTURE	_____	108.00	153.00	_____
8' POLE LIGHT—2 FIXTURES	_____	124.00	179.00	_____

Must Pick up Items at Onsite Exhibitor Service Center. See #16 on Terms & Conditions for details.

15' EXTENSION CORD	_____		32.00	_____
POWER STRIP	_____		32.00	_____

Please call for information on any services you require that are not listed here

TRANSFER TOTAL TO BOX #2 ON METHOD OF PAYMENT FORM	TOTAL	_____
---	--------------	-------

PRINT NAME: _____

EMAIL: _____ PHONE: _____

TERMS & CONDITIONS

1. Order with payment & floor plan (for island booths or any booth requiring distribution of electrical services) must be received no later than the deadline date on the order form for advance payment rates to apply. Orders received without payment and required floor plan will not be guaranteed advance rates. Orders received after the deadline date will be charged at the regular rate. A purchase order or photocopy of a check are not considered valid forms of payment for securing advanced rate.
2. To receive advance rates a complete order inclusive of a scaled electrical layout must be received before the advance payment deadline date. The scaled layout must match the order and include power locations and orientation. Any changes or additional services received after the deadline date will be charged the regular payment price.
3. In the event order totals are calculated incorrectly, Edlen reserves the right to make the necessary corrections and charge the corrected amount. Exhibitors will be notified by email of any such corrections.
4. Outlet rates listed include bringing services to one location at the rear of inline and peninsula booths.
5. Outlet rates listed **do not** include the connection of any equipment, special wiring, or distribution of the outlets, to other than the standard locations within the booth space. Distribution to all other locations *regardless of booth type* require labor and is performed on a time and material basis. Exhibitors are invited to contact the local Edlen office to discuss any additional costs that may be incurred.
6. A separate outlet must be ordered for each location where an electrical service is required. 5 amps or 500 watts is the minimum amount of power that can be ordered for any one location. Power must be ordered according to peak amperage ratings.
7. Island Booths - Will incur a minimum (1) hour labor charge for installation. The removal of this work will be charged a minimum (1/2) hour or (1/2) the total time of installation. Material charges will apply. Return a floor plan layout of your booth space indicating a main distribution point and all outlet locations with measurements and orientation. If a main distribution point is not provided, Edlen will deliver to the most convenient location.
8. There is a (1) hour installation and a (1/2) hour removal charge for Island Booths that require delivery to one location.
9. Labor rates are based on current wage scales and are subject to change in the event of a wage increase after rates have been published. A minimum charge of (1) hour labor will apply for all installation work. The removal of this work will be charged a minimum of 1/2 hour or 1/2 the total time of installation, plus material.
10. Edlen Supervision—A supervisory charge of 10% of the prevailing labor rate will apply to all labor that exceeds one hour.
11. For a dedicated outlet, order a 20 amp outlet.
12. No inverters, self contained power supplies or devices that convert battery power to 120 volt power allowed.
13. In the event 1000 watt overhead quartz lights cannot be mounted to existing catwalks in the convention hall, lift and labor charges will apply. Contact our local office to discuss any additional charges.
14. Edlen employees are authorized to cut floor coverings when essential for installation of services unless otherwise directed.
15. Edlen is the exclusive provider of all material and equipment used in the distribution of temporary electrical services throughout the exhibit hall including the exhibitor booth space. This material is provided on a rental basis ONLY and remains the property of Edlen. It shall be removed only by Edlen employees.
16. Any extension cords or power strips ordered on the front of this form should be picked up at the Exhibitor Service Center. Credit will not be issued for unused items.
17. Standard wall and other permanent building utility outlets or sockets are not part of a booth space and may not be used by exhibitors unless electrical services have been ordered through Edlen.
18. All equipment regardless of source of power, must comply with federal, state and local codes. Edlen reserves the right to inspect all electrical devices and connections to ensure compliance with all codes, for which labor charges can be incurred. Edlen is required to refuse connections where the Exhibitor wiring or equipment is not in accordance with electrical codes.
19. All electrical equipment must be properly tagged and wired with complete information as to the type of current, voltage, phase, cycle, horsepower, etc., required for operation.
20. All Exhibitors' cords must be a minimum of 14 gauge, 3 wire and grounded. Two (2) wire extension cords are not allowed. All exposed, non-current carrying metal parts of fixed equipment which are liable to be energized, shall be grounded.
21. Payment in full must be rendered during the event. Exhibitors ARE NOT billed for services provided. Services may be interrupted if payment is not received.
22. Credit will not be given for services installed and not used. All orders are subject to a 25% cancellation fee if cancelled in writing and received by Edlen (21) calendar days or less prior to the first contracted event move in date. Except sales tax, Edlen will not refund overpayment in amounts less than \$50.00 unless specifically requested in writing.
23. If the event is cancelled within 90 days prior to the first contracted event move-in day all orders are subject to a 25% cancellation fee. No refunds will be issued for events cancelled on or after the first contracted event move-in day.
24. Claims will not be considered or adjustments made unless filed in writing by Exhibitor prior to the close of the event.
25. Exhibitor holds Edlen harmless for any and all losses of power beyond Edlen's control, including, but not limited to, losses due to utility company failure, permanent power distribution failure, power failure caused by vandalism, faulty Exhibitor equipment or overloads caused by Exhibitor.
26. It is agreed that in the event it becomes necessary to turn this matter over to an attorney for collection, or to file a lien, or foreclosure, or otherwise, Exhibitor will pay Edlen its attorney fees or applicable agency fees.
27. A service charge of 1.5% per month on any unpaid balances will be assessed starting 10 days after date of invoice. A \$25.00 service charge will be assessed for all returned checks and credit cards. Exhibitor agrees to reimburse Edlen for all applicable rental taxes.
28. Exhibitor hereby agrees to all terms and conditions outlined on all order forms and the Edlen General Data Protection Regulation (GDPR) privacy policy which can be reviewed by visiting: <https://ordering.edlen.com/LegalNotices/Terms-Edlen-GDPR.pdf>

COMMONLY ASKED QUESTIONS - WHERE WILL MY OUTLET BE LOCATED?

Outlets are located as depicted below for inline & peninsula booths. All other locations require labor on a time & material basis. Exhibitors with hard wall booths must make arrangements with Edlen to bring power inside the booth on a time and material basis.

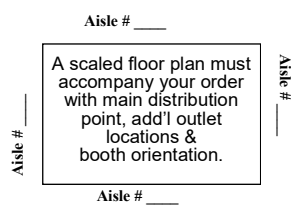
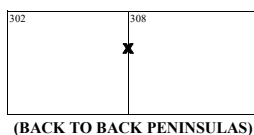
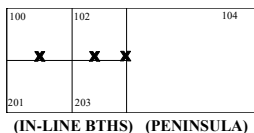

ISLAND BOOTHS

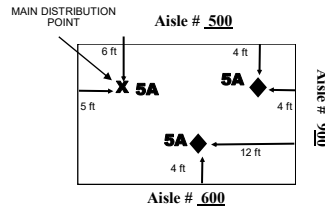

EXAMPLE-FLOOR POWER

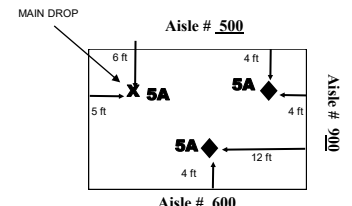

EXAMPLE-CEILING POWER

**FOR OTHER COMMONLY ASKED QUESTIONS VISIT OUR WEBSITE @ WWW.EDLEN.COM
OR CALL THE NUMBER ON THE ELECTRICAL ORDER FORM**

ELECTRICAL LABOR INSTRUCTIONS

Advance Payment Deadline Date: 10/27/24



ELECTRICAL EXHIBITION SERVICES
1201 Houston Street, Fort Worth, TX 76102
Phone: (682) 410-9336
fortworth@edlen.com

EXHIBITOR:		BTH #	
EVENT:	NAAA Annual Aviation Expo 2024		
FACILITY:	Fort Worth Convention Center		
DATES:	November 17-21, 2024	EVENT #	114004FW

LABOR ORDERING INSTRUCTIONS

Step 1 Review Jurisdiction Information Below

The work outlined under Electrical Jurisdiction below must be performed by Edlen Electricians and cannot be performed by any other union or I&D House. Determine the type of work required in your booth space and complete the corresponding labor forms. The Power Delivery section indicates if power typically comes from the ceiling or the floor which may impact your booth layout.

Step 2 Complete the Appropriate Form

There is a different form utilized to schedule labor in your booth space. This allows exhibitors to pre-pay the estimated labor cost. This is only an estimate. Final labor and/or lift cost may be greater or less depending on time required and minimum labor charges.

A. Electrical Distribution

This form is used for the distribution of power on the floor in your booth space. This form should be completed for all island booths. Inline and peninsula booths need to provide this information only if power is required at any other location than the rear of the booth space.

Step 3 Return the following forms to Edlen

Electrical Order, Method of Payment, applicable Labor Forms and Electrical Layout.

ELECTRICAL JURISDICTION

WORK REQUIRING EDLEN ELECTRICIANS

1. Delivery of main power line to Island Booths only
2. Electrical distribution under carpet or overhead
3. Connection of all high voltage services
4. Hardwiring of any electrical apparatus
5. Installation of lighting hung from ceiling
6. Assembly & installation of lighting hung from truss
7. Motor, truss, rigging installation and cabling

POWER DELIVERY

Power is typically delivered from the floor in this facility and is brought to one main distribution point. From this point it is distributed to all other locations in the booth space. Depending on the total power requirements an electrical panel may be placed at the main distribution point. Electrical panels utilize a minimum of 1'x1'6" floor space. Please call if you have any concerns.

ELECTRICAL DISTRIBUTION

Advance Payment Deadline Date: 10/27/24



ELECTRICAL EXHIBITION SERVICES
 1201 Houston Street, Fort Worth, TX 76102
 Phone: (682) 410-9336
 fortworth@edlen.com

EXHIBITOR:		BTH #	
EVENT:	NAAA Annual Aviation Expo 2024		
FACILITY:	Fort Worth Convention Center		
DATES:	November 17-21, 2024	EVENT #114004FW	

ELECTRICAL DISTRIBUTION UNDER CARPET

ALL Island booths MUST provide the information below. Inline and peninsula booths need to provide this information ONLY if power is required at any location other than the rear of the booth space. This information allows Edlen the opportunity to expedite move-in by having your power distribution complete prior to your scheduled move-in time. Complete all of the fields below including the "Labor Estimate" Section. Edlen will make every attempt to complete the work prior to your arrival, but it can not be guaranteed.

1. Provide an Electrical Layout Form:
 - A. The electrical layout must indicate each power outlet and its location with exact measurements.
 - B. The electrical layout must reflect booth orientation. Use surrounding booth or aisle numbers.
 - C. Identify a main distribution point. Power is delivered to that point and then distributed to other locations. Inline or peninsula booths do not need to provide a main distribution point. Power will be located at the rear of the booth.
 - D. If power is only required in one location in Island booths, indicate that location with measurements on your electrical layout.
2. What date will you begin building your booth?
 - A. Date: _____ Time: _____
3. Will you be utilizing any specialty floor covering other than carpet, such as vinyl or wood?
 - A. Describe flooring: _____
 - B. Estimated date and time flooring installation will begin. Date: _____ Time: _____
4. Show site supervisor:

Name _____ Cell # _____

Email _____ Company _____
5. The exhibitor acknowledges there is a minimum 1 hour labor charge for the distribution of services and 1/2 hour for the removal of services. Island booths that only require power delivered to one location incur a 1 hour installation and removal charge.
6. In the event a lift is required to deliver power from the ceiling, or if the exhibitor requests power be delivered from above when it's available on the floor, lift charges will apply for installation and removal. There is a minimum 1 hour installation and 1 hour removal cost for both lift and labor. For safety reasons lifts require a 2 man crew.

LABOR RATES AND HOURS		DISTRIBUTION LABOR ESTIMATE		
Labor Minimums	Enter a minimum of 1 hour for installation and 1/2 hour for removal. For installation labor greater than 1 hour, dismantle is 1/2 the total installation time.	MAN HRS	RATE	TOTAL
		ST	\$100.39	
		OT	\$150.46	
SCISSOR LIFT RENTAL				
		HOURS	RATE	TOTAL
			\$179.00	
TRANSFER ESTIMATED TOTAL TO BOX #3 ON METHOD OF PAYMENT FORM		ESTIMATED TOTAL		

AUTHORIZATION	
PRINT NAME:	DATE:

ELECTRICAL EXHIBITION SERVICES
 1201 Houston Street, Fort Worth, TX 76102
 Phone: (682) 410-9336
 fortworth@edlen.com

EXHIBITOR:		BTH #	
EVENT:	NAAA Annual Aviation Expo 2024		
FACILITY:	Fort Worth Convention Center		
DATES:	November 17-21, 2024	EVENT #114004FW	

FOR YOUR CONVENIENCE PLACE YOUR ORDER ONLINE AT WWW.EDLEN.COM

IMPORTANT NOTES

ADDITIONAL CONNECTIONS
 If you have more than one machine or multiple connections on a machine, you must order an additional connection for each machine or connection within 20 feet of the outlet ordered. Otherwise you must order another outlet.

AIR LINE RESPONSIBILITIES
 Edlen is not responsible for moisture, oil, or water in air lines, loss of flow, or increase in pressure in line to equipment. Exhibitor should supply their own filters, driers, or other equipment as needed. No compressors are permitted other than those supplied by Edlen unless they are a fixed part of your machine.

WATER PRESSURE
 Pressure may vary. No guarantee can be made to minimum or maximum pressures. If pressure is critical, the Exhibitor should arrange to have a pressure regulator valve or pump installed. Edlen is not responsible for sediment, color or taste of water.

LABOR NOTES

OUTLET DELIVERY
 There is a minimum labor charge of 1 hour to deliver and 1/2 hour to remove each air, water, and drain outlet. Outlets are delivered to the rear of inline and peninsula booths, and to one location in island booths. If a lift is required to drop the outlets from the ceiling, a 1 hour lift charge for installation and 1 hour for removal will apply.

OUTLET DISTRIBUTION
 Once outlets have been delivered, the raming and/or distribution of services on the floor will be done on a time and material basis. A minimum 1 hour labor charge for installation and 1/2 hour for removal will apply.

OUTLET CONNECTIONS
 Special equipment requiring company engineering or technicians for assembly, servicing, preparatory work and operation may be executed without Edlen plumbers.

TERMS & CONDITIONS
 I agree in placing this order that I have accepted Edlen's payment policy and the terms and conditions of contract.

UTILITY SERVICES **ADVANCE REGULAR TOTAL**

COMPRESSED AIR: 90-100 LBS. PSI AVAILABLE IN WEST HALL ONLY

Air Outlet (call for a quote for 24-hour Air)	353.60	530.40	
Additional Connections within 20' of Outlet	135.20	202.80	

CFM REQUIREMENTS
Must order CFM with air services. Refer to # 8 on Plumbing Terms, Conditions & Regulations.

CFM (There is a 5 CFM minimum charge per outlet/connection)	Total CFM =		
Total CFM _____ x ADVANCE Rate	7.00	=	_____
Total CFM _____ x REGULAR Rate		11.00 =	_____

WATER LINES (Edlen is not responsible for sediment or the color or taste of water.)

Water Outlet	354.00	531.00	
Additional Connections within 20' of Outlet	136.00	203.00	

of connections required: _____ Size of connection: _____
 PSI required: _____ GPM Required: _____

DRAIN LINES (If waste water contains hazardous materials, chemicals, or metals, Edlen cannot drain it.)

Drain Outlet	354.00	531.00	
Additional Connections within 20' of Outlet	136.00	203.00	

Number of connections required: _____ Size of connection required: _____

FILL & DRAIN LABOR (Edlen is not responsible for sediment or the color of water)

1 – 500 Gallons	216.00	324.00	
-----------------	--------	--------	--

All water and air service will be reviewed and have the potential to be installed aerially. Labor and material charges will apply. You can request an estimate via email. Please send your order and floor plan to fortworth@edlen.com.

LABOR

Labor is required for all air, water, & drain lines, as well as distribution of services in your booth space or overhead. Complete the Plumbing Distribution form and include it with your order.

GAS & MISCELLANEOUS REQUIREMENTS (Call for a Quote)

TRANSFER TOTAL TO BOX #4 ON METHOD OF PAYMENT FORM	TOTAL	
---	--------------	--

PRINT NAME: _____

EMAIL: _____ PHONE: _____

ELECTRICAL EXHIBITION SERVICES
 1201 Houston Street, Fort Worth, TX 76102
 Phone: (682) 410-9336
 fortworth@edlen.com

EXHIBITOR:		BTH #	
EVENT:	NAAA Annual Aviation Expo 2024		
FACILITY:	Fort Worth Convention Center		
DATES:	November 17-21, 2024	EVENT #114004FW	

Go to the exhibitors tab at www.edlen.com for an exact grid to match your booth space.

POWER ORIGINATES FROM THE FLOOR IN THIS VENUE

Power is delivered from a floor port to a “main distribution point” in island booths and then distributed from that point. Indicate this location and all other outlet locations using the legend & grid below. Inline and peninsula booths need to provide this information only if power is needed at any other location than the rear of the booth. (See T&C page 3 for examples):

INDICATE BOOTH TYPE	INDICATE SCALE & TOTAL SQ FT	OUTLET LEGEND
Island _____ Inline _____ Peninsula _____	Example: 1 Square = 1 Foot _____ Square = _____ Ft Total Square Footage = _____	X = Main Distribution Point ▲ = 5amp/500 watt ◆ = 10amp/1000 watt ● = 20amp/2000 watt

Adjacent Booth or Aisle # _____

Adjacent Booth or Aisle # _____

Adjacent Booth or Aisle # _____

Adjacent Booth or Aisle # _____

PLUMBING DISTRIBUTION

Advance Payment Deadline Date: 10/27/24



ELECTRICAL EXHIBITION SERVICES
1201 Houston Street, Fort Worth, TX 76102
Phone: (82) 410-9336
fortworth@edlen.com

EXHIBITOR:		BTH #	
EVENT:	NAAA Annual Aviation Expo 2024		
FACILITY:	Fort Worth Convention Center		
DATES:	November 17-21, 2024	EVENT #114004FW	

PLUMBING JURISDICTION

The work described below falls within the jurisdiction of Edlen Plumbers and cannot be performed by any other union, I&D house or exhibitor. Contact our office for clarification regarding scope of work.

- Delivery of Air, Water and Fill & Drain lines
- Installation of lines delivered from overhead
- Distribution of Air, Water & Drain lines under carpet

1. REVIEW EACH SECTION AND COMPLETE LABOR ESTIMATE

A. Outlet Delivery & Removal

There is a minimum 1 hour labor charge for the delivery and 1/2 hour for the removal of each air, water and drain service. If a lift is required to drop services from overhead, a minimum 1 hour for installation and 1 hour for removal will apply.

B. Outlet Distribution Throughout Booth Space

Air, Water and Drain lines are brought to one location at the rear of inline, peninsula and island booths. If you require the distribution of services to any other location within the booth space, there is a minimum 1 hour labor charge for distribution and 1/2 hour for removal, or 1/2 the total time of installation, whichever is greater.

C. Outlet Connections

Connection to exhibitor equipment is included in the cost of the service.

2. DISTRIBUTION OF SERVICES IN BOOTH SPACE

A. Island Booths need to provide the following information:

1. The plumbing layout must indicate each outlet and its location with exact measurements.
2. Each location should indicate the type of service. All air locations must include CFM requirements.
3. The plumbing layout must reflect booth orientation. Use surrounding booth or aisle numbers.
4. Identify a main distribution point. Services are delivered to that point and then distributed to other locations.

B. Inline or Peninsula booths must provide the same information with the exception of the main distribution point. The main distribution point will be located at the rear of the booth space.

C. Date you will begin building your booth: _____ Estimated time: _____

D. Will you be utilizing any specialty floor covering other than carpet, such as vinyl or wood?

1. Describe flooring: _____

E. What time do you estimate needing the physical connection to your equipment? Date: _____ Time: _____

F. Show site supervisor: _____ Company: _____

Cell #: _____ Email: _____

G. This information allows Edlen the opportunity to expedite move-in by having your plumbing distribution complete prior to your scheduled move-in time. Complete the "Labor Estimate" Section below. Edlen will make every attempt to complete the work prior to your arrival.

LABOR ESTIMATE		
MAN HOURS	RATE	TOTAL
_____ ST	\$100.39	_____
_____ OT	\$150.46	_____
_____		_____

ESTIMATED TOTAL	_____
------------------------	-------

TRANSFER ESTIMATED TOTAL TO BOX #3 ON THE METHOD OF PAYMENT FORM

WORK RATE SCHEDULE	
ST	Monday - Friday, 8:00 AM - 4:30 PM, except Holidays.
OT	Monday - Friday 4:30 PM - 8:00 AM & all day Saturday, Sunday and Holidays.

AUTHORIZATION

PRINT NAME: _____

DATE: _____

PLUMBING LAYOUT

Advance Payment Deadline Date: 10/27/24

EDLEN
The Power People
ELECTRICAL EXHIBITION SERVICES
1201 Houston Street, Fort Worth, TX 76102
Phone: (82) 410-9336
fortworth@edlen.com



EXHIBITOR:		BTH #	
EVENT:	NAAA Annual Aviation Expo 2024		
FACILITY:	Fort Worth Convention Center		
DATES:	November 17-21, 2024	EVENT #	114004FW

Go to the exhibitors tab at www.edlen.com for an exact grid to match your booth space.

PLUMBING SERVICES ORIGINATE FROM THE COLUMNS IN THIS VENUE

Air, water & drain services are delivered from a floor port to a “main distribution point” in island booths and then distributed from that point. Indicate this location and all other outlet locations using the legend & grid below. Inline and peninsula booths need to provide this information only if these services are needed at any other location than the rear of the booth. (See T&C page 3 for examples):

INDICATE BOOTH TYPE	INDICATE SCALE & TOTAL SQ FT	OUTLET LEGEND
Island _____	Example: 1 Square = 1 Foot	X = Main Distribution Point W = Water A = Air D = Drain AC = Add'l connection
Inline _____	_____ Square = _____ Ft	
Peninsula _____	Total Square Footage = _____	

Adjacent Booth or Aisle # _____

Adjacent Booth or Aisle # _____

Adjacent Booth or Aisle # _____

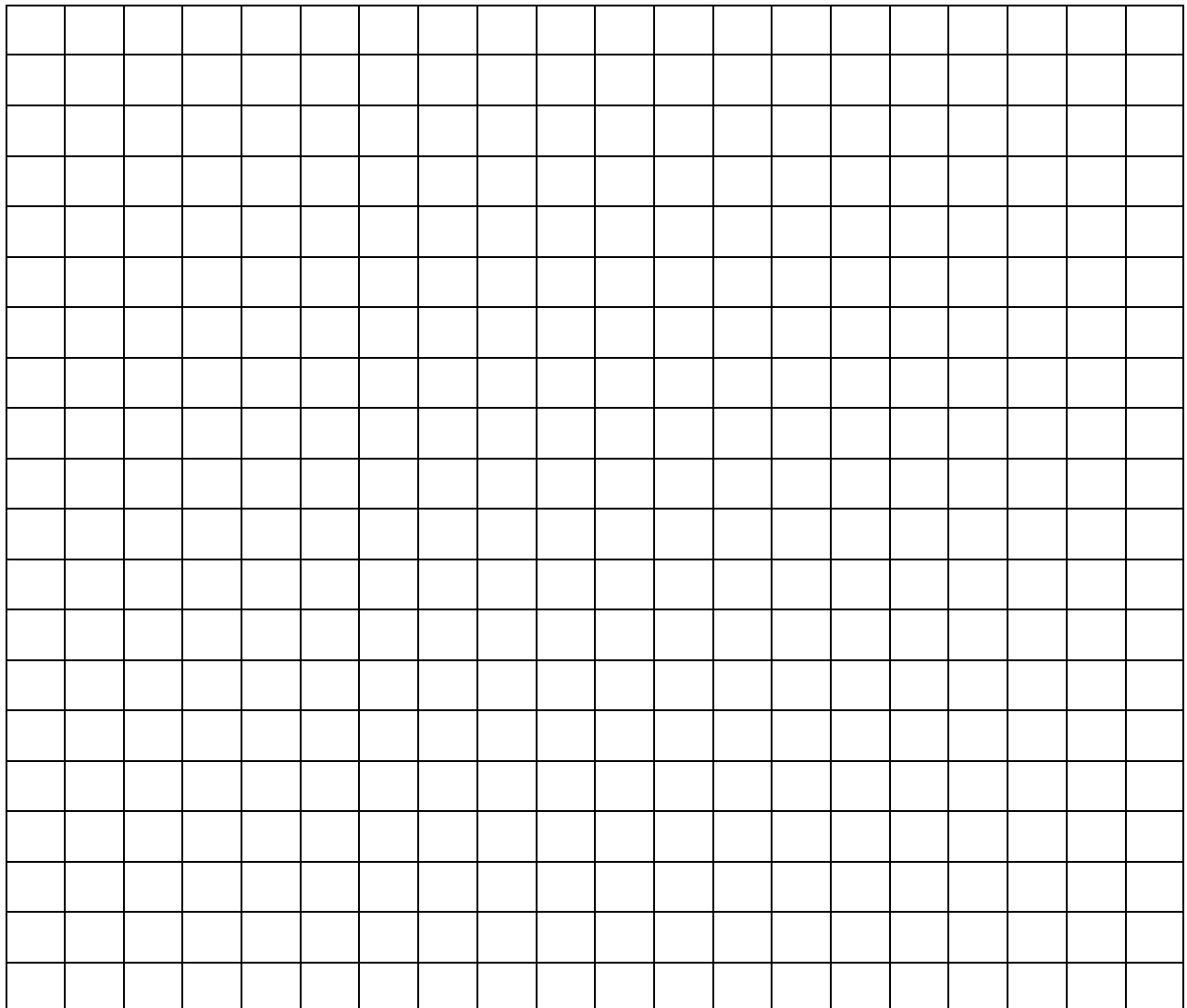

Adjacent Booth or Aisle # _____

PLUMBING TERMS, CONDITIONS & REGULATIONS

1. A complete order with payment and floor plan inclusive of a scaled layout (for island booths or any booth requiring distribution of plumbing services) must be received no later than the deadline date for advance payment rates to apply. Orders received without payment and required floor plan are not guaranteed advance rates. Orders received after the deadline date will be charged at the regular rate. A purchase order or photocopy of a check are not considered valid forms of payment for securing advanced rate.
2. To receive advance rates a complete order inclusive of a scaled plumbing layout must be received before the advance payment deadline date. The scaled layout must match the order and include plumbing locations and orientation. Any changes or additional services received after the deadline date will be charged the regular payment price.
3. In the event that totals are calculated incorrectly, Edlen reserves the right to make the necessary corrections. Exhibitors will be notified by email of any corrections made. This includes adding the required minimum CFM charges when applicable and labor charges.
4. All outlets will be installed on the floor at the back wall of inline and peninsula booths. All services ordered for island booths will be dropped to one location in the booth. Edlen will make every attempt to deliver these services to a location convenient to the exhibitor.
5. Distribution of services throughout the booth space, whether under the carpet, above the carpet or overhead is done on a time and material basis. Lift charges may also apply for overhead distribution.
6. Additional footage charges apply when an Exhibitor requires services that are further than 90 feet away from closest outlet and when dropped from overhead when services originate on the floor or columns.
7. Labor charges apply when an exhibitor requires services to be dropped from overhead when services originate on the floor or columns.
8. The CFM requirements (Cubic Feet per Minute) determine the volume of air required to properly operate exhibitors equipment. CFM is a labor charge for sizing and installation of the service infrastructure.
9. In some instances a pump is required to drain services out of an exhibitor's booth. When this occurs, time & material charges apply. Exhibitors are encouraged to contact Edlen to discuss any potential additional costs.
10. Connection to exhibitor equipment is included in the cost of the service. Special equipment requiring company engineering or technicians for assembly, servicing, preparatory work and operation may be executed without Edlen plumbers.
11. Service outlet size is determined by the volume required. Air line size is dictated by the CFM requirements and air line terminations vary.
12. Compressed Air is supplied during show hours only. If compressed air is required for non-show hours call for a quote.
13. Wall, column and permanent building utility outlets are not part of booth space and are not to be used by exhibitors.
14. Unless otherwise directed, Edlen personnel are authorized to cut floor coverings to permit installing service(s) ordered.
15. Pressure for Water Services may vary. No guarantee can be made of minimum or maximum pressure. If pressure is critical, the exhibitor should arrange to have a pressure regulator valve installed.
16. Natural Gas "when available" is not regulated by Edlen and is at the facility pressure. Call for price quote when available.
17. Gas & Cylinders "when available" 1025 - 1030 BTU per cubic foot at 7' water column pressure. Credit will not be provided on unused cylinders.
18. All equipment using water must have inlet and outlet properly tagged.
19. All equipment must comply with state and local codes.
20. Edlen will not be responsible for moisture or water in air lines. Exhibitors should supply their own filter or other equipment to handle moisture or water.
21. For gas cylinders or any other special requirements call for a quote. Delivery charges will apply to any specialty equipment delivered and removed from the exhibitor booths.
22. Edlen must have 30 days notice in order to supply special regulators, strainers, traps, etc.
23. Credit will not be given for services installed and not used. All orders are subject to a 25% cancellation fee if cancelled in writing and received by Edlen (21) calendar days or less prior to the first contracted event move in date. Except sales tax, Edlen will not refund overpayment in amounts less than \$50.00 unless specifically requested in writing.
24. If the event is cancelled within 90 days prior to the first contracted event move-in day all orders are subject to a 25% cancellation fee. No refunds will be issued for events cancelled on or after the first contracted event move-in day.
25. Claims will not be considered or adjustments made unless filed in writing prior to close of the event; no exceptions.
26. Credit will not be given for outlets installed or connections made and not used.
27. Payment in full for all plumbing services provided must be made in full prior to close of the event.
28. It is agreed that in the event it becomes necessary to turn this matter over to an attorney for collection, or to file a lien, or foreclosure, or otherwise, exhibitor will pay Edlen its attorney fees or applicable agency fees.
29. A service charge of \$25.00 will be assessed for all returned checks or declined credit cards.
30. A service charge of 1.5% per month on any unpaid balances will be made starting 10 days after date of invoice.
31. Exhibitor hereby agrees to all terms and conditions outlined on all order forms and the Edlen General Data Protection Regulation (GDPR) privacy policy which can be reviewed by visiting: <https://ordering.edlen.com/LegalNotices/Terms-Edlen-GDPR.pdf>

**POWER TO OPERATE ANY PLUMBING APPARATUS IS NOT INCLUDED.
ALL ELECTRICAL REQUIREMENTS MUST BE ORDERED ON THE ELECTRICAL FORM.**

For further information please visit our web site WWW.EDLEN.COM
or call the number on the Plumbing Order form

FWCC Exhibitor
Telecom Product List
(Coming Soon)

FWCC WiFi Options

(Coming Soon)



RIGGING PRICES

Ferrand Hardy | C: 817-401-6620 | O: 214-441-1528 | F: 214-441-1582 | ferrandh@INSPIRESolutions.com

LABOR (Monday - Friday):

Lead Rigger	\$75/hr
Rigger/Lift Operator	\$75/hr
Per Point Charge	\$45/day (3 Day Max)

Based on a 2 man, 4 hour minimum

Note: Inspire is the exclusive rigging provider in the facility for anything over 150 pounds

EQUIPMENT:

1 Ton Motor	\$150*
1/2 Ton Motor	\$125*
10' Truss 12x12	\$8/ft
10' Truss 20x20	\$10/ft
Lift	\$250/day

*Price is for one rental period of up to 3 days.

A new rental period will begin on day 4, and again on each 4th day.

FORT WORTH CONVENTION CENTER



RIGGING POLICY

To effectively ensure life safety and maintain the aesthetic and structural integrity of our ceiling, the following policies regarding rigging apply. The policies, rules, and regulations set forth in this document are meant as a guideline for this location, and may not be all inclusive. Additional policies, rules, and local regulations may apply.

It is understood that Inspire is responsible for all rigging decisions and will work with the venue, sales team and clients in advance to provide suggestions which will ensure that everything overhead is rigged properly and safely. Inspire riggers will not take rigging instruction or direction from anyone except qualified/certified riggers, licensed engineers, or the Inspire Director of Rigging.

Recommendations made by the rigging department are based upon manufacturer specifications; ETCP, OSHA, ANSI, ESTA, and USITT standards; as well as any local city, Fire, Police, State or Health regulations per location. Each property may also have their own internal regulations which may need to be recognized.

Inspire riggers have the final word on anything being rigged. Any questions or concerns by any local or Inspire rigger must be reviewed and approved by the Director of Rigging.

Inspire will provide all rigging hardware and labor required for attaching motors to the building and the truss to the motors. Anything overhead and over 50lbs is considered "Rigging". Any additional rigging for audio, video or scenic elements which attach to the truss will need to be discussed.

A rigging plot must be submitted and clearly display loads, equipment counts, equipment positions, and cable picks. This must be submitted electronically no later than 21 days prior to scheduled load-in. Acceptable file formats: DWG, VectorWorks, or scaled PDFs. Inspire is required to approve all rigging plots.

All requests for rigging services and hardware must be received 21 days prior to load-in date to ensure proper staffing. Requests received later than 21 days prior to load-in may incur additional fees.

The number of riggers required will be decided by Inspire based on size and production schedule of the event.

Exceedingly large rigs that support abnormal loads or non-uniform distribution of weight or hardware may require plans that have to be approved and stamped by a licensed engineer selected by the venue.

On shows larger than 25 points, a Production Rigger will be assigned and given 4-8 hours of pre-production time to review the plot and plan the load-in for the riggers, including any phone and email correspondence between client and production. Production Rigger will also provide 11"x17" and 24"x36" plots for riggers during load-in.

Cable bridges may be requested for cable runs of more than 4 Socapex.

No rigging hardware will be used outside of the manufacturer's recommended use; no exceptions.



RIGGING POLICY

Inspire RIGGERS ARE RESPONSIBLE FOR THE FOLLOWING:

Create and install any necessary semi-permanent points where available.

Make all motor connections to the building structure via acceptable temporary or permanent rigging points.

Make all cable pick connections to the building, or any loads greater than 150lbs.

Determine who will mark the floors: event production or Inspire staff. Assist accordingly.

Lay out motor power and control. Coordinate motor cable runs with production and client.

Wrap the truss and float rig to working height. Level the truss out with tape measure; prepare for trim.

Make/verify motor connection to audio bumpers and fly to trim.

Make/verify motor connections, cage connections, and safeties for video, LED walls, etc.

Make/verify any scenic or decorative rigging elements.

Verify safety of entire rig when complete; run out to trim and laser level as necessary.

Clean and drop motor power and control as necessary. Secure the rig.

Clear and arrange leftover gear and cases, and prepare for load out.

Make arrangements for lifts to be powered and charged.

Verify departure/release status from Inspire and confirm schedule for next day or load out.

RIGGERS WILL NOT take a break or leave site without the Client or Lead Rigger's approval.

Cable picks, cable tie backs, audio cluster focus, cable swags etc., can be done by riggers after the main rig is flown to trim. These items can also be done by any lighting, video, or audio hand, when available. Based on schedule timing, it will be the client's decision whether to keep riggers on the clock to clean cable runs, or allow each department to handle their own cable management.

Riggers will provide the point of connection to the building, but are not required to run each department's cables. Each department will be expected to manage their cables properly, and be responsible for providing clean runs, bundles and swag. Riggers will not be expected to clean mismanaged cables in the air.

Rigging plots will be presented to Inspire no less than 21 days from production load-in date. We can run load calculations, but client must provide a complete instrument legend with manufacturer name, model number, and weights.

FORT WORTH CONVENTION CENTER



RIGGING REGULATIONS & SAFETY GUIDELINES

RIGGING EQUIPMENT GUIDELINES

All rigging hardware, steel, gackflex, spansets, and STAC chains must have proper visible manufacturer's tags with load ratings, including any cross-rented gear or gear provided by production or the client. Any hardware without proper identification tags will not be used as per OSHA and ANSI Standards.

Inspire will maintain annual load testing and maintenance certificates for all chain hoists based on the manufacturers' guidelines and ASME standards for overhead hoists, ASME B30.16d-1997.

Log books of all rigging steel, truss, harnesses, spansets, motors, training, etc., can be provided upon request.

A steel "safety" is required on each individual item suspended with a nylon sling. Gackflex slings are exempt. All nuts and bolts used overhead must be properly rated and all overhead hardware (eyebolt etc.) must be forged. Nothing from chain hardware stores is rated for overhead use and will not be permitted as rigging hardware.

Rigging equipment provided by the client or other vendors must also comply with these same guidelines and must provide all certifications upon request prior to load-in.

ON-SITE PRACTICES

Rigging from any lighting fixtures, plumbing or sprinkler fixtures, electrical conduit, air ducts or any support mechanism is strictly prohibited.

Inspire will not "dead hang" items over 150lbs or 10' in length with a scissor lift. Chain hoists or crank towers must be used.

Cable runs that consist of 4 or more socapex runs and are 10' or more away from the rig might be required to use a cable bridge and motors.

Additional weight cannot be applied to flown equipment after Inspire riggers leave the room.

Nothing in the air moves without Inspire riggers being present.

Only Inspire riggers will operate any chain hoist unless previously discussed and decided, or unless the client is providing their own motors and rigging.

Under no circumstances will anyone climb ground-supported truss or archways. The climbing of any truss structure can only be done with proper vertical and horizontal fall arrest systems.

Flown equipment may only be moved by a Inspire rigger. Riggers will remain on the call until all flown equipment is at trim height.

SCISSOR AND BOOM LIFTS

Inspire can provide lifts with operators. Clients may also rent or bring their own lifts.

Property Lifts: Owned by the property, operated only by the property. Inspire can operate when permissions and insurance allows.

Inspire Lifts: Owned or rented by Inspire. Operated only by Inspire or those covered by Inspire insurance. It should be determined in advance what qualifies a lift operator, and who operates the lifts once the riggers are cut. Lighting lift op, audio lift op, video lift op, etc.

External Lifts: Lifts provided and operated by the client, covered under client's rental agreement.

LOAD LIMITS

Load limits are typically 1,000lbs per point. See venue CAD drawings for specific details per property.

All beams must be wrapped with burlap or carpet when building the rigging points.

Bridles and side loads are not allowed in some venues.

Riggers will have final approval for all things flown or lifted overhead.



RIGGING REGULATIONS & SAFETY GUIDELINES

PPE: PERSONAL PROTECTION EQUIPMENT

Hard hats, safety vests, eye protection, steel toes, harnesses, fall arrest and life lines are required as necessary.

Hard hats must be inspected for structural cracks and fractures before and after each use.

Tape and stickers are not permitted on safety helmets as they prevent proper inspection of damage or defects.

Harnesses shall be inspected thoroughly before and after each use.

Harnesses are required in boom lifts, as per the manufacturer.

Harnesses are not required in scissor lifts by the manufacturer, but some venues may require the use.

BANNERS AND SIGNAGE

Banners and signs usually require custom rigging harnesses or hardware to suspend them properly. If the client does not have this gear, Inspire can assist in fabricating safe solutions, but arrangements need to be made in advance and may include additional time and charges.

Fabricating hardware for banners and signage: The materials used to temporarily rig have extremely minimal cost, so they are all expendable items.

Temporary safe rigging solution: The use of Rize Blocks along with 1/16" or 1/8" wire rope. When used together within the manufacturer's load limits, these items are industry-recognized and rated as a safe rigging practice. After use, the rig is disassembled, Rize Blocks are returned to inventory, and the wire rope is disposed of.

Disposable fabricated rigging: swagging custom hardware for client use is also acceptable, and becomes the client's property after use. They are paying for the materials and labor, so the client keeps the custom hardware. Items fabricated are for temporary use only and cannot become Inspire inventory, nor allowed to mix with Inspire inventory. Without manufacturer tags and load ratings, these items cannot be considered reusable inventory.

All signs, banners, and decorations hung in ballrooms and over 150lbs must be inspected and approved by a Inspire rigging supervisor prior to load-in.

Banner placement inside of ballrooms and or meeting rooms must be approved in advance through Inspire.

Signs may not obstruct fire exits or sprinkler heads, and must have a clearance of no less than 18".

All signs must meet NFPA and local Fire Marshal guidelines.



RIGGING POSITION DESCRIPTIONS

Riggers will be booked for the following positions as required, with the following expectations.

Rigging Manager: Manages various venues on a property, or properties with larger shows, or a larger number of shows. Books the labor & divides staff & freelance resources as necessary. Manages annual log books for rigging inventory, inspection records, training records and rigging staff requirements. Maintains the rigging inventory. Primary point of communication with the Director of Rigging, keeping current with safety codes and regulations. Will be ETCP Certified, OSHA 30, Tomcat University, CM hoist certified, Vector Works friendly, and we will provide all the training. Stays on the floor, working with the client and managing labor, not expected to Up Rig but can assist with Ground Rig duties as available. Maintains a Favorite Riggers list; including staff, local labor, union labor, freelance labor, out of town labor, etc. Completion of working at heights and fall arrest class, separate from the OSHA 10 or 30 class.

Production Rigger: Usually on larger shows, 60 motors or more. May be provided as client production staff or by Inspire as necessary. Communicates all rigging with the client. Advises on load limits, motor distribution and cable management. Determines the order of flight with client when each truss goes up. Runs load calcs. Creates working plots for the riggers. Chooses the R2 and has preferential selection of the riggers. Establish crew requirements, production schedule, necessary scissor, boom and fork lifts.

Lead Rigger: Typically, the lead local rigger (staff or labor), manages the local riggers as per Production Rigger's instructions on shows larger than 60 motors. Same duties as the Production Rigger on shows less than 60 motors. Has preferential selection of the riggers as necessary. Manages the Up Riggers, Ground Riggers, breaks and meals. Riggers will take breaks as needed and when they are at a safe stopping point at their discretion, which might not match actual break schedules. It is preferred that the Lead Rigger stay on the ground, available to the Production Rigger at all times, unless otherwise determined.

R2, Assistant Lead: #2, takes over if the Production or Lead Rigger becomes unavailable. Knows everything the Production Rigger knows. Has copies of all plots and production documentation. Capable of completing the end results as designed and expected.

Up Rigger: Climbing riggers or rigging from scissor/boom lifts; makes the point of connection to the building as necessary, following building guidelines. Responsible for anything overhead above 150lbs. Depending on the venue, will assist with ground duties after Up Rigging is completed and a proper break has been allowed. For arena rigging & extreme heat ceiling conditions, ground duties will be stated if necessary, prior to booking labor.

Down/Ground Rigger: Stays with the Up Rigger. Keeps the ground safe and clear, manages the safety of the people below the rigger. Sets the motors in place and lights up the point with a laser for the Up Riggers, sends up chains and necessary rigging hardware. Helps with placement of 8x/4x motor distros and helps run motor fly cables as available without neglecting the safety of the Up Rigger. Manages empty cases and leftover gear.

Motor Electric: Additional Ground Riggers or Electricians available for motor power distribution and control placement. Responsible for managing motor fly cables cleanly and neatly from the distro to the motor. Labels all cables, distros and controllers accordingly. Helps disconnect, clean and coil motor power and control lines or motor cable swags after rig is at trim. Provides or locates power sources for charging the lifts. Primarily meant to stay on the ground, but can become available for minor lift operations.

FORT WORTH



CONVENTION CENTER

Listed below are the Fort Worth Convention Center's **exclusive service providers**:

- **Catering:** Trinity Food & Beverage Services, Inc.
Lilliam Berlingeri, Director, Catering & Convention Services
817.392.2584 (office) or lberlingeri@trinityfbs.com (email)
- **Electrical:** Edlen Electric
Brian Fischer, General Manager
682.410.9336 (office) or bfischer@edlen.com (email)
- **Telecommunications (internet, wifi, etc...):** Cox Communications
Scott Cloninger, Account Executive
833-320-3294 or scott.cloninger@cox.com (email)
- **Ballroom/Exhibit Hall/Arena Rigging:** Inspire Solutions (formerly J&S Audio Visual)
Ferrand Hardy, Director, Operations
972.241.5444 x262 (office), 817.401.6620 (cell) or ferrandh@jsav.com (email)

Updated: 2.2.24

Ag Aviation 2024 Ft Worth Convention Center Ft Worth, TX November 19–20, 2024



(770) 507-6777
FAX (770) 474-4676
order@tfc-florist.com
www.tfc-florist.com

N•A•T•I•O•N•A•L
convention • plant • services

Exhibitor Name: _____ Booth Representative: _____
 Firm, Billing Name: _____ Purchase Order or Reference Number: _____
 Booth Number: _____ Credit Card #: _____ Ex Date _____
 Billing Address: _____ CVV# _____ *Pay via ACH to avoid cc proc fee, email req to order@tfc-florist.com*
 City: _____ State: _____ Zip: _____ Name of Credit Card Holder as shown on card _____
 Show Decorator: _____
 Phone: _____ Fax: _____ Authorized Signature: _____
 Cell: _____ Email Address: _____

HOW TO ORDER: Email order to order@tfc-florist.com/ Mail hard copy to: P.O. Box 538, Rex, GA 30273 or 121 Pine Dr., Stockbridge, Ga 30281 / or Fax to (770) 474-4676 Questions? Please email plant@tfc-florist.com or call (770) 507-6777
*** PRICES IN BOLD PRINT ARE DISCOUNT PRICES FOR ORDERS RECEIVED 2 WEEKS PRIOR TO EXHIBITOR MOVE-IN**

FROM SIMPLE AND ELEGANT TO WILD AND COLORFUL! LET A TLC DESIGNER CREATE THE PERFECT LOOK JUST FOR YOU!

If you would like to specify color, size, type flowers, please do so below—**prices start at \$80.00.**

Qty _____ tropical flowers—Price \$ _____ each

Qty _____ Spring flowers—Price \$ _____ each

Color _____

Width _____ Height _____

Additional Request: _____

*Don't know what you want? Just want a splash of color?
Let TLC designers choose your fresh seasonal flowers!*

Qty _____ TLC pick my colors, size, type flowers \$70.00 ea

Visit www.tfc-florist.com for additional sample pictures.
For free design assistance, please call 770-507-6777 or email plant@tfc-florist.com with any questions.



TLC Designers can provide the following:

- **Water Features**
 - **Fountains**
 - **Ponds**
 - **Water falls**
 - **Swamps**
 - **Garden Areas**
 - Tropical :**
(beach scenes;
rain forests)
 - Seasonal:**
(Spring, Fall, Holiday)
 - Formal :**
(serenity garden,
English garden)
 - **Border Areas:**
 - Hedges**
(control flow)
 - Lawn or Golf**
(promotional)
 - Trees**
(privacy)
- Special services are Available for hospitality Suites, award banquets, And VIP room deliveries.**

COLORFUL POTS OF VIBRANT FLOWERS!

Seasonal

12"-18"H

\$40.00/\$50.00 each

Qty _____

White _____

Yellow _____

Lavender _____

Orange _____

Pink _____



Azaleas—12"H

\$40.00/\$50.00 each

Qty _____

White _____

Pink _____

Red _____

Bromeliads—12"-18"H

\$40.00/\$50.00 each

Qty _____

Purple _____ Red _____

Yellow _____ Orange _____

*See next
page for
green plants.*

Ferns



Ferns
\$40.00/\$50.00 each
 Qty ____

Ivy



Ivy—10”H x 10”W
\$40.00/\$50.00 each
 Qty ____

Pothos



Pothos—12”H x 12”W
\$40.00/\$50.00 each
 Qty ____

3’ Green Plants



\$50/\$60.00 each Qty ____

Standard 4’ to 6’ Green Plants



4’ @ **\$60/\$70** each Qty ____
 5’ @ **\$70/\$80** each Qty ____
 6’ @ **\$80/\$96** each Qty ____

7’ H & Taller plants & Planters are available
 Call 770-507-6777 for price/availability

Top-dressed with seasonal flower and greenery.

___ white, ___ pink, ___ red
 ___yellow, ___lavender

4’ @ **\$145/\$175** each, Qty ____
 5’ @ **\$155/\$185** each, Qty ____
 6’ @ **\$165/\$200** each, Qty ____

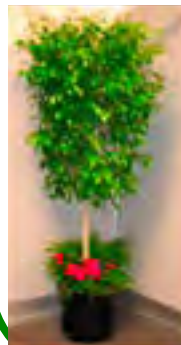

Seasonal Flowering Plants
 Call for Price & Availability

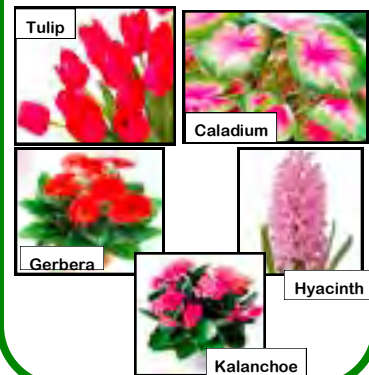

Planters are 2 1/2’ long.

Rental price includes: Decorative container, top dressing, professional maintenance, installation and pick up. There is a one-time \$10.00 charge for **daily** floral delivery. **ALL ORDERS MUST BE PAID – IN – FULL PRIOR TO SHOW CLOSING.** We accept cash, company check, VISA, MASTERCARD, AMERICAN EXPRESS. Adjustments cannot be made after the close of the show. All rental items remain property of TLC Atlanta Convention Plant Services, Inc. **There is a restocking fee for orders cancelled less than 2 weeks prior to show opening. Orders placed after the open of an event may be subject to a delivery fee.**
Prices subject to change 2 weeks prior to move in.

Order Cost Summary

Select Container (Included in rental cost) Subtotal _____
 ___Black ___White 10% Delivery _____
 Chrome, Brass, Terra Cotta, & Other Containers are available. 3% CC Proc Fee _____
 Please call 770-507-6777 for pricing. Request ACH pmt invoice when emailing this order to avoid 3% fee
 Total _____